

# MAC 2000 Performance II

user manual

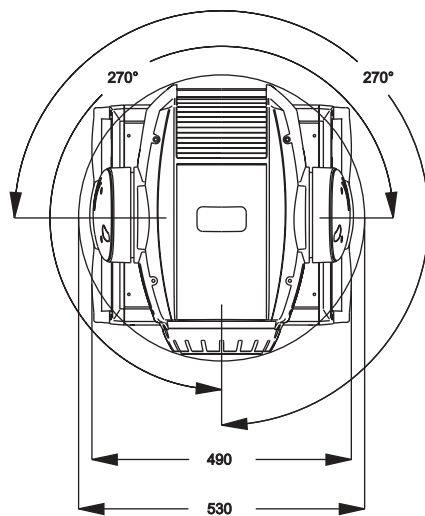

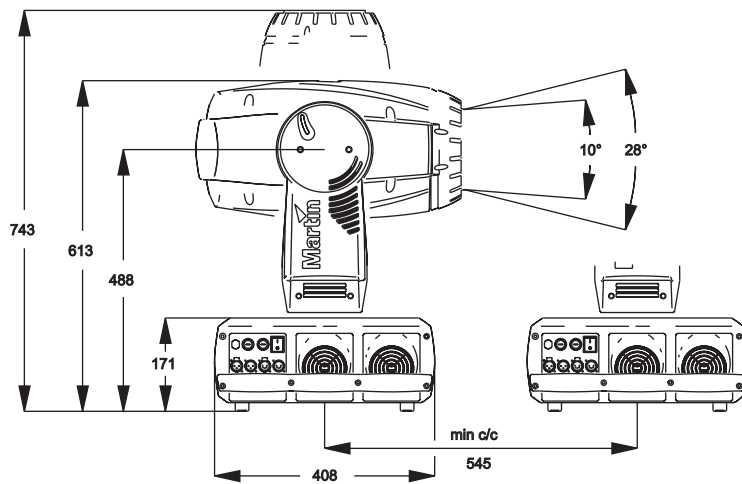
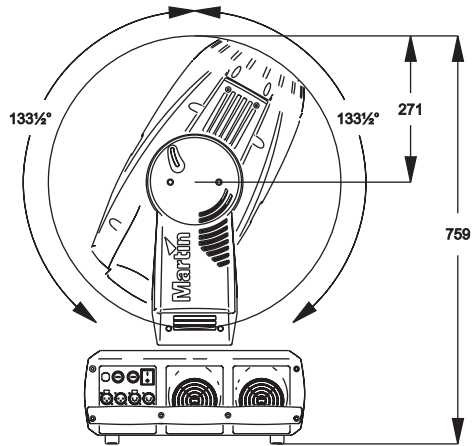

INTRODUCTION . . . . .	5
Safety information . . . . .	5
TRANSPORTATION . . . . .	7
Included items . . . . .	7
Transport locks . . . . .	7
Single flight case . . . . .	7
Double flight case . . . . .	8
LAMP . . . . .	9
Lamp replacement . . . . .	9
Replacing the lamp socket . . . . .	10
AC POWER . . . . .	11
Fuses . . . . .	11
Power supply adjustments . . . . .	11
Power connection . . . . .	11
Reduced power function . . . . .	11
DATA . . . . .	12
Connecting fixtures . . . . .	12
RIGGING . . . . .	13
CONTROL PANEL . . . . .	14
Navigation . . . . .	14
DMX address and protocol setting . . . . .	14
Tailoring performance . . . . .	14
Readouts . . . . .	15
Service messages . . . . .	16
Service utilities . . . . .	16
EFFECTS . . . . .	18
Framing shutters . . . . .	18
Gobos . . . . .	18
Gobo animation system . . . . .	18
Dimming and strobe . . . . .	19
Color mixing . . . . .	19
Color temperature correction . . . . .	19
Effect wheel . . . . .	19
Iris . . . . .	19
Focus and zoom . . . . .	19
Pan and tilt . . . . .	19
Speed control . . . . .	20
ANIMATION GUIDE . . . . .	21
General animation tips . . . . .	21
Animation discs and their uses . . . . .	22
Effects ideas . . . . .	24
OPTICAL CONFIGURATION . . . . .	31
Rotating gobo wheel . . . . .	31
Effect wheel . . . . .	34
Gobo animation . . . . .	34
ROUTINE MAINTENANCE . . . . .	36
Cleaning . . . . .	36
Software installation . . . . .	37
DMX PROTOCOL . . . . .	38
16-bit protocol . . . . .	39
8-bit protocol . . . . .	42
CONTROL MENU . . . . .	45
ADJUSTMENT SUBMENU . . . . .	49

DISPLAY MESSAGES .....51  
TROUBLESHOOTING .....53  
CIRCUIT BOARD CONNECTIONS .....54  
SPECIFICATIONS  
MAC 2000 PERFORMANCE II .....55

# INTRODUCTION

Thank you for selecting the MAC 2000 Performance II. The MAC 2000 Performance II is a 1200 W moving head spotlight that provides CMY color mixing, continuous color correction (CTC), four-blade framing system, motorized iris, gobo wheel with five indexable rotating gobos, indexable gobo animation wheel, effect wheel with 3 effects (wide-angle converter lens, non-rotating nine-facet prism and variable frost), combined dimmer/shutter, focus, zoom, 540° of pan, and 267° of tilt. The MAC 2000 Performance II has an electronic ballast that provides flicker-free operation, an economic power-saving mode, and an auto-ranging switch-mode power supply (SMPS) that removes the need for manual adjustments to the transformer or ballast.

For the latest firmware updates, documentation, and other information about this and all Martin Professional products, please visit the Martin web site at <http://www.martin.com>.

## Safety information

**Warning!** *This product is for professional use only. It is not for household use.*

This product presents risks of lethal or severe injury due to fire and heat, electric shock, ultraviolet radiation, lamp explosion, and falls. **Read this manual** before powering or installing the fixture, follow the safety precautions listed below and observe all warnings in this manual and printed on the fixture. If you have questions about how to operate the fixture safely, please contact your Martin dealer or call the Martin 24-hour service hot line at +45 70 200 201.

### Protection from electric shock

- Disconnect the fixture from AC power before removing or installing the lamp, fuses, or any part, and when not in use.
- Always ground (earth) the fixture electrically.
- Use only a source of AC power that complies with local building and electrical codes and has both overload and ground-fault protection.
- Do not expose the fixture to rain or moisture.
- Refer any service operation not described in this manual to a qualified technician.

### Protection from UV radiation and lamp explosion

- Never operate the fixture with missing or damaged lenses and/or covers.
- When replacing the lamp, allow the fixture to cool for at least 15 minutes before opening the fixture or removing the lamp. Protect your hands and eyes with gloves and safety glasses.
- Do not stare directly into the light. Never look at an exposed lamp while it is lit.
- Replace the lamp if it becomes defective or worn out, or before usage exceeds the maximum service life.

### Protection from burns and fire

- Never attempt to bypass the thermostatic switch or fuses. Always replace defective fuses with ones of the specified type and rating.
- Keep all combustible materials (for example fabric, wood, paper) at least 1.0 meter (39 inches) away from the fixture. Keep flammable materials well away from the fixture.
- Do not illuminate surfaces within 1.0 meter (39 inches) of the fixture.
- Provide a minimum clearance of 0.1 meters (4 inches) around fans and air vents.
- Never place filters or other materials over the lens.
- The exterior of the fixture can get very hot. Allow the fixture to cool for at least 5 minutes before handling.
- Do not modify the fixture or install other than genuine Martin parts.
- Do not operate the fixture if the ambient temperature (Ta) exceeds 40° C (104° F).

## **Protection from injury due to falls**

- Do not lift or carry the fixture alone.
- When suspending the fixture, verify that the structure can hold at least 10 times the weight of all installed devices.
- Verify that all external covers and rigging hardware are securely fastened and use an approved means of secondary attachment such as a safety cable.
- Block access below the work area whenever installing or removing the fixture.

# TRANSPORTATION

**Important!** Release the transport locks before operating the fixture.

## Included items

The MAC 2000 Performance II is shipped in a 1 or 2 unit flight case that contains the following items.

- User manual
- 2 x 20 A main fuses (for use with 100-130 V local power supply)
- 2 x 15 A main fuses (for use with 200-250 V local power supply)
- 4 additional animation wheels
- 2 aluminium gobos
- 2 clamp attachment brackets
- XLR cable

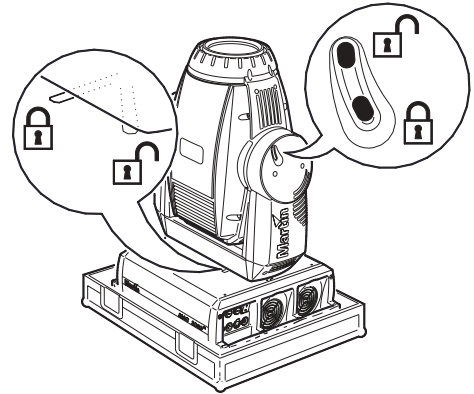

Figure 1: Pan and tilt locks

## Transport locks

The head and yoke may be locked for transportation and service. The locks are shown in Figure 1. The fixture must be unlocked before operation.

## Single flight case

### Unpacking the fixture

- 1 Remove the top of the flight case.
- 2 With one person on each side, lift the fixture out of the bottom of the flight case.
- 3 Release the pan and tilt locks before operating.

### Packing the fixture

- 1 Disconnect the fixture from power and allow it to cool.
- 2 Lock the head and yoke in the position shown in Figure 2.
- 3 Place the fixture in the bottom of the flight case. Place the top section over the fixture without forcing.

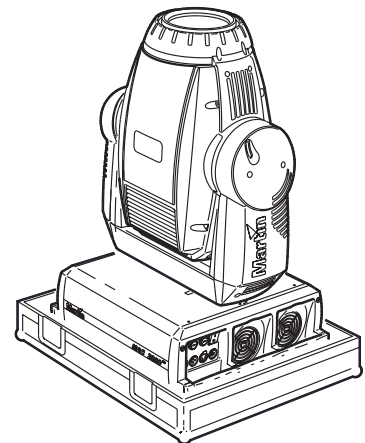

Figure 2: Single unit transport position

# Double flight case

## Unpacking

- 1 Open the flight case and pull the drawer all the way out.
- 2 Release the head (tilt) transport lock.
- 3 Install rigging hardware as described on page 13.
- 4 With one person on each side, lift the fixture out of the flight case.

## Packing

- 1 Disconnect the fixture from power and allow it to cool.
- 2 Turn the yoke parallel to the sides of the base with the tilt lock closest to the back.
- 3 Pull the transport drawer all the way out. With one person on each side, place the fixture on the drawer with the arrow pointing in.
- 4 Remove and stow rigging hardware. Coil and stow the power cord in the door.
- 5 Tilt the head so that the lens points away from the door as shown in Figure 3. Lock the head in the horizontal position. Do not lock the yoke.
- 6 Slide the drawer all the way in without forcing. Close the flight case.

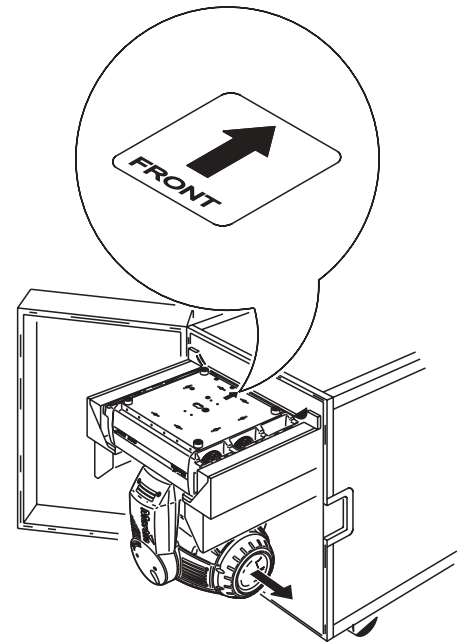

Figure 3: Double unit transport position

## Setup for flight case testing

The double flight case has two slide-out arms from which the fixture can hang for testing and setting. Though unnecessary, the pan and tilt reset can be cancelled by pressing [Menu] and [Enter] at the same time when powering on.

- 1 Open the flight case and pull the drawer all the way out. Release the transport locks.
- 2 Pull the test arms all out. Tilt the fixture up and over the slide arms so that the handle cross-braces that are second from the back rest on the arms. The fixture should rest at an angle.
- 3 Push the transport drawer into the flight case.



# LAMP

The MAC 2000 Performance II is supplied with a Philips MSR 1200 SA/DE GOLD 1200 W discharge lamp installed. This source has a color temperature of 6000 K, a color rendering index greater than 85, and an average life of 750 hours.

The lamp is capable of hot restrike. This feature, however, is only supported by the MAC 2000 Performance II with electronic ballast.

The ends of the lamp are profiled with special keys, as shown in Figure 6, to ensure proper installation. Do not use lamps with keys in a non-keyed SFC 10-4 socket.

**Warning!** *Install only an approved lamp (see “Source” on page 55). Installing any other lamp may create a safety hazard or damage the fixture!*

The lamp should be replaced when it has reached the limit of its 750 hour average life. To reduce the risk of explosion, never exceed 125% of the lamp’s average life, i.e. 940 hours. To read lamp hours from the control panel, please refer to “Readouts” on page 15.

For optimum performance, avoid turning off the lamp before it has warmed up fully.

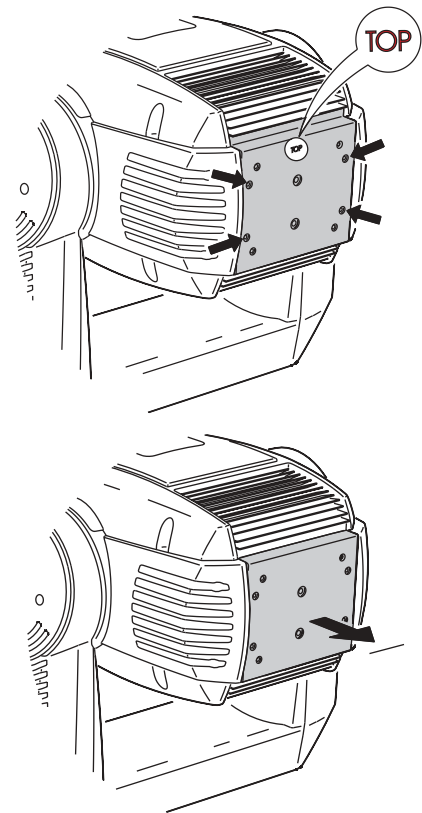

Figure 4: Lamp access

## Lamp replacement

**Important!** *Do not touch the quartz bulb with bare fingers.*

The lamp can be replaced with either a:

- Philips MSR 1200 SA/DE GOLD (Martin P/N 97010310), or an
- OSRAM HMI 1200 W/S (Martin P/N 97010304).

Both lamps are available from your Martin dealer.

The clear quartz bulb must be clean and free of any oils from your fingers. Clean the lamp with an alcohol wipe and polish it with a dry cloth, particularly if you accidentally touch the bulb.

### Replacing the lamp

- 1 Disconnect the fixture from power and allow it to cool. Lock the head horizontally with the top up.
- 2 See Figure 4. Release the 4 quarter-turn fasteners marked with arrows on the rear plate. Pull the lamp assembly straight back as far as it goes and let it rest in place.
- 3 See Figure 5. Pull the retention spring on the left-hand end of the lamp socket up and then swing the end of the lamp out. Pull the other end out of the socket.
- 4 Inspect the socket for corrosion (see “Replacing the lamp socket” on page 10) and replace if necessary.

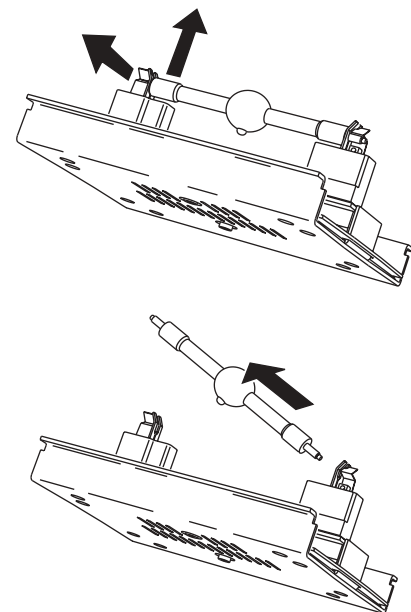

Figure 5: Lamp removal

- 5 See Figure 6. With the nipple on the bulb facing the back, insert the right end of the new lamp in the socket. Pull up on the left spring and snap the other end into place.
- 6 Lift the lamp assembly so that lamp is level with the center of the reflector. Push the assembly straight in until it seats, making sure the lamp passes through the reflector opening. Lock the 4 quarter-turn fasteners.
- 7 When installing a new lamp, reset the lamp hour and lamp strike counters as described in "Time" on page 15.

### Aligning the lamp

- 1 Switch on the MAC 2000 Performance II and allow it to reset. Using either a controller or the control module, turn on the lamp and project an open white beam on a flat surface.
- 2 Center the hot spot vertically using the top Allen-head adjustment screw in the center of the rear plate.
- 3 If there is significant hot spot, turn the bottom adjustment screw counterclockwise until the light is evenly distributed. If the light is brighter around the edge than it is in the center, or if light output is low, turn the bottom adjustment screw clockwise until the light is bright and evenly distributed.
- 4 Repeat step 2.

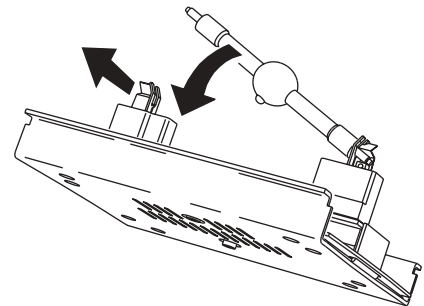
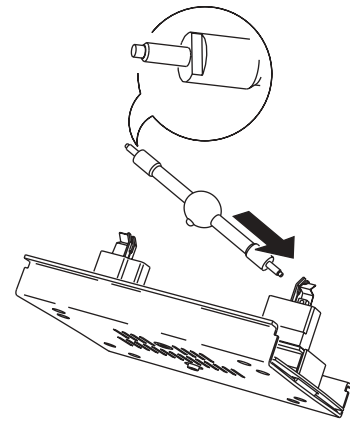

Figure 6: Lamp insertion

### Replacing the lamp socket

A corroded lamp socket can lead to a bad contact, causing damage to the lamp. Damage caused by lack of maintenance of the lamp socket is not covered under warranty.

Inspect the lamp socket each time the lamp is changed, and replace it if its gold coating has corroded (turned a deep black color). We recommend routine replacement of the socket after maximum 4000 hours of use (replace one socket for every five lamps).

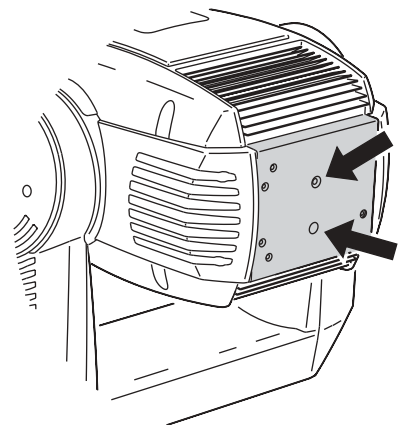

Figure 7: Lamp adjustment

# AC POWER

**WARNING!** For protection from electric shock, the fixture must be grounded (earthed). The AC mains supply shall be fitted with a fuse or circuit breaker and ground-fault protection.

**Important!** Verify the power supply settings before applying power.

The chapter describes:

- Installing fuses
- Power supply adjustments for the various MAC 2000 Performance II models
- Connection to a power supply (see page 11)
- The reduced power function (see page 11)

## Fuses

The MAC 2000 Performance II comes with two:

- 20 AT (time delay) main fuses for use with AC supplies of 100 - 120 volts.
- 15 A main fuses for use with AC supplies of 200 - 250 volts.

Install the appropriate fuses in the holders near the power switch.

## Power supply adjustments

The MAC 2000 Performance II (identified as such by the label on the base of the product) comes with an electronic ballast and an auto-sensing, auto-ranging switch-mode power supply. Manual adjustments to the transformer or ballast are not necessary as the MAC 2000 Performance II automatically adapts to the mains voltage and frequency.

## Power connection

**Important!** Connect the MAC 2000 Performance II directly to AC power. Do not connect it to a dimmer system; doing so may damage the fixture.

You may need to install a cord cap that fits your supply on the power cable. A 3-prong grounding-type plug must be installed following the manufacturer's instructions. The table shows some possible pin identification schemes; if the pins are not clearly identified, or if you have any doubts about proper installation, consult a qualified electrician.

To apply power, set the power switch on the base to the "I" position.

Wire Color	Pin	Symbol	Screw (US)
brown	live	L	yellow or brass
blue	neutral	N	silver
yellow/green	ground		green

Table 1: Cord cap connections

## Reduced power function

The MAC 2000 Performance II has an automatic power reduction function, which reduces the consumption to 700W if the shutter/dimmer is closed for more than 10 seconds. This not only increases the lamp life, but also further decreases the overall noise emission of the fixture.

# DATA

**Important! Never connect more than 1 data input and 1 data output.**

The MAC 2000 Performance II has both 3-pin and 5-pin XLR sockets for DMX input and output. The pin-out on all sockets is pin 1 to shield, pin 2 to cold (-), and pin 3 to hot (+). There is no connection to pins 4 and 5.

The sockets are wired in parallel: both inputs connect to both outputs. *For reliable data transmission and to avoid damage to the fixture, however, use one input and one output!*

## Connecting fixtures

- Use shielded twisted-pair cable designed for RS-485 devices: standard microphone cable cannot transmit control data reliably over long runs. 24 AWG cable is suitable for runs up to 300 meters (1000 ft). Heavier gauge cable and/or an amplifier is recommended for longer runs.
- Never use both outputs to split the link. To split the serial link into branches use a splitter such as the Martin 4-Channel Opto-Isolated RS-485 Splitter/Amplifier.
- Do not overload the link. Up to 32 devices may be connected on a serial link.
- Terminate the link by installing a termination plug in the output socket of the last fixture. The termination plug, which is a male XLR plug with a 120 ohm, 0.25 watt resistor soldered between pins 2 and 3, “soaks up” the control signal so it does not reflect and cause interference. If a splitter is used, terminate each branch of the link.
- Martin fixtures introduced before 1997 have reversed polarity data sockets (pin 2 hot and pin 3 cold). The socket polarity is labelled. *Use a phase-reversing cable between the MAC 2000 Performance II and any Martin device with reversed polarity.*

## Connecting the data link

- 1 Connect the DMX data input from the controller to the MAC 2000 Performance II's 3-pin or 5-pin input (male) socket.
- 2 Using the sockets that match your data cable, connect the output of the fixture closest to the controller to the input of the next fixture.
- 3 Insert a male 120  $\Omega$  XLR termination plug in the 3-pin or 5-pin output of the last fixture on the link.

# RIGGING

The MAC 2000 Performance II can be placed on stage or clamped to a truss in any orientation. The Fast-Lock system enables quick and easy fastening of the clamp brackets in 4 positions as shown Figure 8.

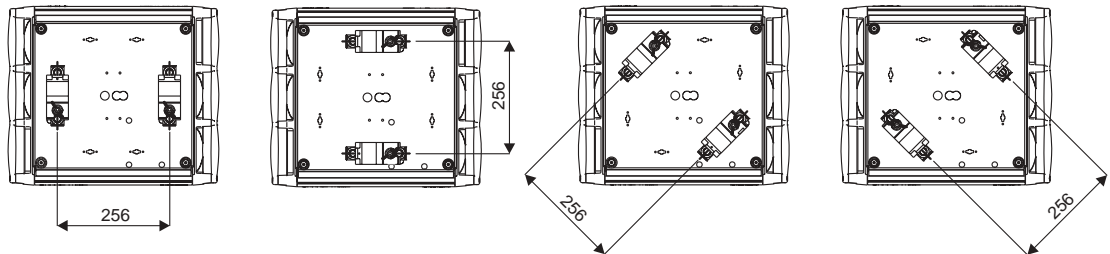

Figure 8: Clamp bracket positions

**Warning!** Always use 2 clamps to rig the fixture. Lock each clamp with both 1/4-turn fasteners. The fasteners are locked only when turned fully clockwise.

**Warning!** Attach an approved safety cable to the attachment hole in the base. Never use the carrying handles for secondary attachment.

## Clamping the fixture to a truss

- 1 Verify that the rigging clamps (not included) are undamaged and can bear at least 10 times the weight of the fixture. Verify that the structure can bear at least 10 times the weight of all installed fixtures, clamps, cables, auxiliary equipment, etc.
- 2 Bolt each clamp securely to a clamp bracket with an M12 bolt (grade 8.8 or better) and lock nut.
- 3 Align a clamp with 2 mounting points in the base. Insert the fasteners into the base and turn both levers a full 1/4-turn clockwise to lock. Install the second clamp.
- 4 If the truss can be lowered, fixtures can be clamped on directly from the double flight case. If the fixture must be lifted, block access under the work area. Working safely from a stable platform, hang the fixture on the truss with the arrow towards the area to be illuminated. Tighten the rigging clamps.
- 5 Install a safety wire that can bear at least 10 times the weight of the fixture. The attachment point is designed to fit a caribiner clamp.
- 6 Verify that the pan and tilt locks are released. Verify that there are no combustible materials or surfaces to be illuminated within 1 meter of the fixture, and that there are no flammable materials nearby.

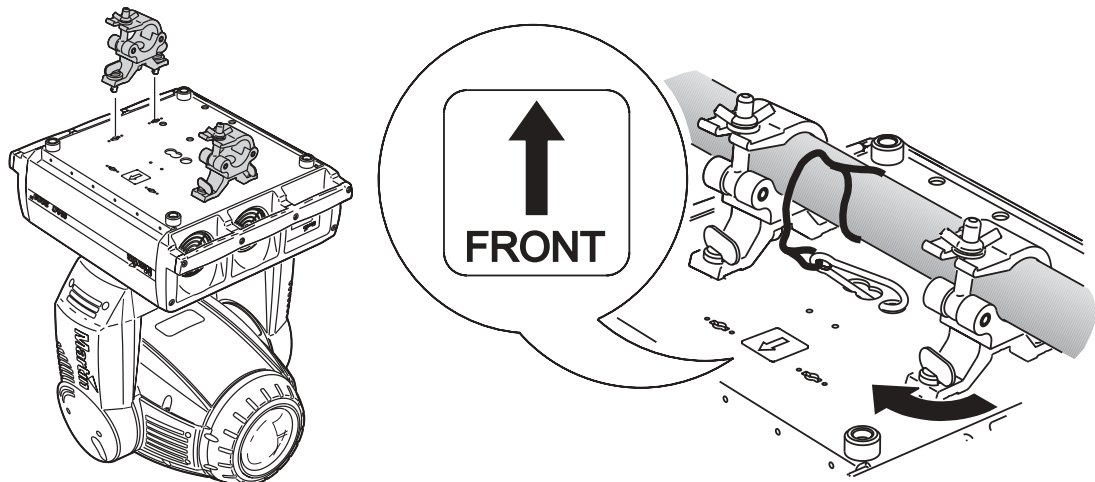

Figure 9: Rigging hardware installation

# CONTROL PANEL

The LED control panel is used to set the address and personalities, read lamp hours and other information, calibrate effects, and run a test routine. Most of these functions may be performed remotely via the serial link with the Martin MP-2 Uploader.

## Navigation

The DMX address and any messages (see page 51) are displayed when the MAC 2000 Performance II is turned on. To enter the menu, press [Menu]. Press [Up] and [Down] to move within the menu. To select a function or submenu, press [Enter]. To escape a function or menu, press [Menu]. See Table 2 on page 45 for a complete list of the menu items.

Note: [Enter] must be pressed and held for a few seconds to enter the utilities menu.

## DMX address and protocol setting

The DMX address, also known as the start channel, is the first channel used to receive instructions from the controller. For independent control, each fixture must be assigned its own control channels. Two MAC 2000 Performance IIs may share the same address, however, if identical behavior is desired. Address sharing can be useful for diagnostic purposes and symmetric control, particularly when combined with the inverse pan and tilt options.

Two DMX protocols, 8-bit and 16-bit, are available. The 8-bit mode uses 28 control channels and provides full basic control. The 16-bit mode uses 3 additional channels to provide finer gobo and pan/tilt positioning.

### Setting the DMX address and protocol

- 1 Press [Menu] to enter the main menu.
- 2 Press [Up] until `Addr` is displayed. Press [Enter]. To snap to channel 1, press [Enter] and [Up]. Scroll to the desired channel and press [Enter].
- 3 Select `PSET` from the main menu and press [Enter]. Select `8bit` or `16bit` and press [Enter].

## Tailoring performance

### Movement

The MAC 2000 Performance II provides six options for optimizing movement for different applications.

- The protocol setting (`PSET`) setting selects 8-bit or finer 16-bit control of pan, tilt, and gobo index.
- The pan and tilt invert (`PATI`) menu swaps and/or inverts pan and tilt.
- The pan/tilt speed (`PTSP`) menu provides 3 settings: `FAST`, `NORM`, and `SLOW`. `NORM` is best for most applications. `FAST` provides better performance in applications where speed is most important. `SLOW` provides the smoothest movement and is best in long-throw applications with slow movements through narrow angles.
- The studio mode (`STUD`) setting optimizes all effects besides pan and tilt for speed or quietness.
- The shortcuts (`SCUT`) setting determines whether the gobo, and effect wheels always take the shortest path between two static positions or oscillate between outer positions.

### Tracking Response

The MAC 2000 Performance II has a filter algorithm that looks at several position updates in tracking control mode and calculates the ideal response for smooth movement. Tracking response is adjustable to compensate for variations in controller performance. In most cases the default settings work well.

If tracking mode movement is not satisfactory there are 2 parameters that can be adjusted. The first is selected under `PERS/TRAC/MODE`. The default, `MOD1`, is the best choice with controllers that calculate intermediate

positions at a steady rate. Begin by selecting the alternative, `MOD 2`, which is better if the intermediate positions stray significantly from the line of travel.

The second parameter is the number of position updates used to calculate speed. The level is adjustable between 1 and 10 under `PERS / TRAC / CAL`. Increasing the number of samples increases the distance over which speed is calculated, making movement smoother but less responsive to sudden changes. Experiment for best results.

## Display

The display intensity (`dINT`) setting controls display brightness. The display on/off setting (`dISP`) determines whether the display remains on or extinguishes two minutes after the last key-press. To flip the display, press [Up] and [Down] simultaneously.

## Lamp

There are two settings that modify lamp control: Automatic Lamp On (`ALON`) and DMX Lamp Off (`DLof`).

When `ALON` is off, the lamp remains off until a “lamp on” command is received from the controller. When `ALON` is on, the lamp strikes automatically after the fixture is powered on. When `ALON` is set to `DMX`, the lamp strikes automatically when the fixture receives DMX data, and it extinguishes 15 minutes after DMX data is lost.

When `ALON` is set to either `ON` or `DMX`, the automatic lamp strike timing is staggered to prevent all lamps from striking at once. The delay is determined by the fixture address.

If striking lamps from the controller, note that striking many lamps at once may cause a voltage drop large enough to prevent lamps from striking or trip the main circuit breaker. Avoid this by programming a “lamp on” sequence that strikes lamps one at a time at 5 second intervals.

Power to the lamp can be turned off from the controller if DMX Lamp Off (`dLOf`) is on.

## DMX reset

The fixture can be reset from the controller if DMX reset (`PERS / dRES`) is ON.

## Custom settings

The custom configuration function allows you to save and recall three sets of fixture settings. The savable settings are DMX mode, pan/tilt speed, pan/tilt inverse and swap, DMX lamp off and reset, display settings, shortcuts, studio mode, automatic lamp on, effects feedback, tracking algorithm, and tracking samples.

## Readouts

Note: The MP-2 Uploader provides commands to display the time, temperature, and version readouts on the fixture control panel.

### Time

`INFO / TIME` provides readouts of fixture hours (`HRs`), lamp hours (`L HR`), and lamp strikes (`L ST`). Under each item is a resettable (`RESET`) increment counter and a non-resettable counter for total accumulated hours/strikes since fabrication (`TOTL`). To reset an increment counter, display it and then press [Up] until it reads 0. (This may also be done remotely using the MP-2 Uploader.)

### Temperature

`INFO / TEMP` provides readouts of the head and base temperature in Celsius and Fahrenheit.

### Firmware version

`INFO / VER` displays the version number of the installed firmware. The firmware version is also displayed briefly at startup.

### DMX

The `DMXL` menu shows the DMX start code (`STCO`) and DMX values received for each effect.

## Service messages

The Service LED on the control panel lights under conditions that require fixture service, and there is a message describing the service required. To display the message, select `SMSG` in the main menu. This item is available only when the LED is lit. There are two service messages.

`Replace lamp` is displayed when the lamp counter exceeds 750 hours, which is the rated average life for the HMI 1200 W/S lamp. The maximum service life is 125% of the average life, or 940 hours.

`Fixture overheating` is displayed when the head temperature exceeds 120° C (248° F). Overheating is likely due to dirty air filters, fans, or air vents; incorrect power supply settings, or a defective fan.

## Service utilities

**Important!** *Enter must be held for several seconds to access the utilities menu.*

### Test sequences

`TSEQ` provides a general test of all effects that can be run without a controller. `UTIL / PCBt` provides routines for circuit board testing that are for service use only.

### Feedback toggles

An on-the-fly position correction system monitors the gobo wheel, gobos, and effect wheel. If a position error is detected, the shutter closes while the effect resets. This feature can be disabled by turning effects feedback (`UTIL / EFFb`) off.

The automatic pan/tilt position correction system may be temporarily turned off under `UTIL / FEbA`. The off setting, however, is not saved and the system will be re-enabled the next time the fixture starts. If the system cannot correct the pan/tilt position within 10 seconds, feedback is automatically disabled.

### Adjustment

The adjustment menu (`UTIL / Adj`) provides manual control for making mechanical adjustments. See page 49.

### Calibration

The calibration menu (`UTIL / CAL`) provides utilities to define offsets in software that are relative to the mechanical reset or home positions. This allows you to fine tune optical alignment and achieve uniform performance between fixtures. Dimmer and zoom are calibrated to defined points. The other effects are calibrated relative to an arbitrary reference fixture.

Default offset settings may be restored by selecting default offsets (`UTIL / dFOF`).

### Calibrating effects

- 1 Apply power but do not strike the lamp until zoom has been calibrated.
- 2 To calibrate zoom, first remove the bottom head cover. Select `UTIL / CAL / ZOO` and press [Enter]. Adjust the offset until the face of the zoom lens plate is flush with the back edge of the focus plate (Figure 10). Press [Enter] to save the setting. Replace the bottom head cover.
- 3 Pan calibration is most useful when multiple fixtures are stacked vertically. To calibrate, set zoom, focus, iris, and tilt position for easy one-over-the-other comparison and set each fixture to the same pan DMX value. Select one fixture to be the reference fixture. On the other fixtures, select `UTIL / CAL / P OF` and press [Enter]. Adjust the offset as necessary to align the beam with the reference beam. Press [Enter] to save the setting.
- 4 Tilt calibration is most useful when multiple fixtures are arranged horizontally. To calibrate, set zoom, focus, iris, and pan position for easy side-by-side comparison and set each fixture to the same tilt DMX value. Select one fixture to be the reference fixture. On the other fixtures, select `UTIL / CAL / T OF` and press [Enter]. Adjust the offset as necessary to align the beam with the reference beam. Press [Enter] to save the setting.



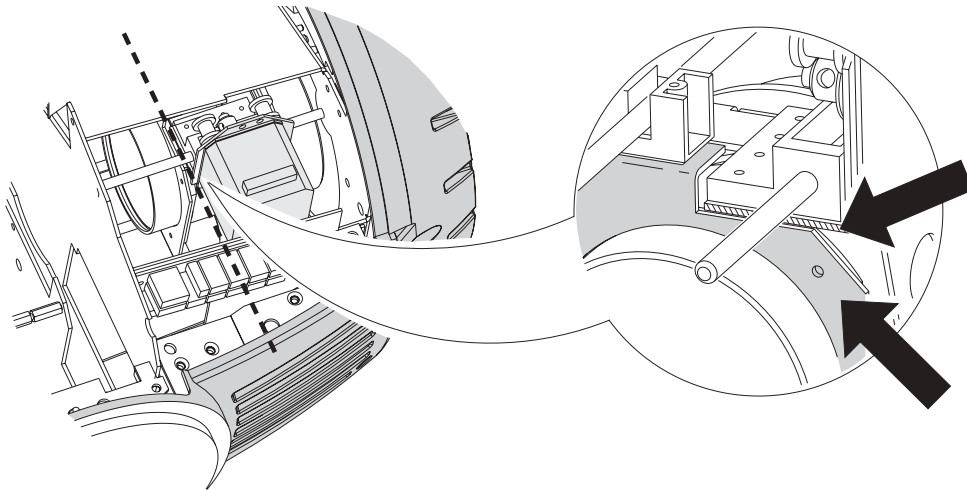

**Figure 10: Zoom calibration point**

- 5 To calibrate the dimmer, select `UTIL / CAL / D OF` and press [Enter]. Hold a piece of paper over the lens. Set the offset to 0 and then increase it until light is clearly projected onto the paper. Press [Enter] to save the setting. Remove the paper.
- 6 To calibrate color mixing flags (cyan, magenta, yellow, and color temperature correction), project white beams with no dimming and position them for easy comparison. On each fixture, *including the reference*, select `UTIL / CAL / C OF` and press [Enter]. (This adds a defined amount of cyan.) Select one fixture to be the reference. Adjust the offsets on the other fixtures to match the reference color. Press [Enter] to save the setting. Repeat for `M OF` (magenta), `Y OF` (yellow), and `CTOF` (CTC).
- 7 Focus calibration is useful when two or more fixtures are the same distance from a projection surface. To calibrate focus, set up all fixtures with the same focus, zoom, dimming, iris, and gobo values. Select a focussed fixture to be the reference. On the other fixtures, select `UTIL / CAL / FOOF` and press [Enter]. Adjust the offset to focus the image. Press [Enter] to save the setting.

## Software upload

The software update mode is normally engaged automatically by the upload device.

# EFFECTS

The MAC 2000 Performance II is compatible with USITT DMX512 controllers. The fixture has two DMX operating modes, 8-bit and 16-bit. 16-bit mode requires three more DMX channels than 8-bit mode but provides more precise gobo indexing and pan/tilt positioning. All other functions are identical. The complete DMX protocol begins on page 38.

## Framing shutters

Optimized for use in theater, the MAC 2000 Performance II features a fully automated, micro-adjusting framing shutter blade system. For accurate illumination of stage props and scenery, this framing system slices the beam into angled shapes.

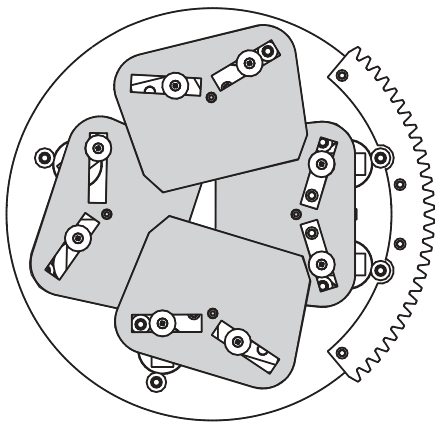

The system comprises four shutter blades, arranged in two layers. With this 2-layer system, the MAC 2000 Performance II has been designed to project shapes with crisp, sharp edges.

Each blade can be swiveled +/- 30 degrees, and the entire module rotates 90 degrees. We recommend that the angle of each blade, and the alignment of the entire module be set to 50% of their DMX value. This will set the frame positioning upright, and the shutter blades at right angles. Refer to the “DMX protocol” on page 38 for the specific channels.

Directly attached to the framing system is the iris. You can use either the iris or the framing system, or both together.

## Gobos

The gobo wheel provides room for 5 gobos. See page 31 to change gobos.

Gobos may be rotated and shaken at varying speeds and indexed to any position. Extremely accurate positioning is available in 16-bit mode.

The gobo and type of rotation (indexed or continuous, with or without shake) are selected on the wheel’s Gobo & Function Channel, which also provide commands for continuous wheel rotation. The gobo position index and rotation speed are selected on its Position/Velocity Channel. In 16-bit mode, the position is further adjusted on the wheel’s Fine Position Channel.

## Gobo animation system

The gobo animation system is designed to create animated effects such as flames, sky and water imaging. The MAC 2000 Performance II comes with 5 replaceable gobo animation wheels, which are magnetically attached to the motor

shaft, and which can be quickly changed. The gobo animation wheel pivots to allow horizontal, vertical, and angled effects, such as rising flames or windswept clouds.

Via your DMX controller, you can control both the starting position of the animation disc and its rotation direction and speed. The animation disc can be set to run continuously or to run in an indexing mode, which will be of great use if you are using custom animation discs with text or company logos. You are also able to choose the angle at which the disc has its starting position, be it horizontally aligned, vertically aligned, or anywhere in between.

For information about:

- Using the gobo animation effects, see “Animation guide” on page 21
- Changing the installed gobo animation wheel, see “Gobo animation” on page 34

## Dimming and strobe

The mechanical dimmer/shutter system provides smooth, high-resolution 100 percent dimming, instant open and blackout, random and variable strobe effects up to 10 Hz, and random and variable pulses in which the dimmer snaps open and slowly dims or snaps closed and slowly opens.

## Color mixing

The color mixing system uses continuous dichroic cyan, magenta, and yellow (CMY) color filters. It is a subtractive system that removes color from white light. Inserting all three filters results in loss of light: for maximum brightness, mix 2 colors at a time.

## Color temperature correction

The color temperature correction (CTC) system uses a continuous 0 - 178 mireds color filter that lowers the color temperature from 6000 K to 2900 K.

## Effect wheel

The effect wheel provides a variable frost filter and two slots that house a wide angle converter lens (beam expander) and a nine-facet prism.

## Iris

The iris closes down to 15 percent of its full-open diameter with high, 200-step resolution. The Iris Channel also provides random and variable speed pulsating iris effects.

## Focus and zoom

The focus lens focusses the beam from approximately 2 meters (6.5 feet) to infinity. The zoom lens widens the beam from approximately 10° at full spot to 28° at full flood.

## Pan and tilt

The yoke pans 540° and the head tilts 267°. For maximum positioning accuracy, select 16-bit mode.

The pan/tilt speed (fast, norm, or slow) may be selected on the pan/tilt speed channel. Setting the pan/tilt speed channel to “blackout” causes the shutter to black out the light while the head is moving.

## Speed control

There are two ways to control the speed at which effects move from one static position to another. These are known as tracking control and vector control and are selected on the Pan/Tilt Speed and Effect Speed Channels. These channels are independent so you may, for example, combine a vector control pan movement with a tracking control color fade.

In tracking mode, speed is determined by the cross-fade time. The controller continuously sends small position changes that the fixture “tracks.” To enable tracking mode, set the relevant speed channel to a tracking value. Note that in addition to enabling tracking control, some tracking values also provide overrides of the menu settings.

In vector mode, speed is set directly on a speed channel. *The cross-fade time must be 0.* Vector control provides a way to set speed on controllers that do not have programmable fade times and results in smooth movement regardless of the cross-fade time or the controller’s processing power.

To open the iris slowly in tracking mode, for example, you program a scene with the iris fully closed and a second scene with the iris fully open. Then you set a cross-fade time between the two scenes of, say, 10 seconds. The controller gradually changes the iris position value from 199 (closed) to 0 (open).

To open the iris slowly in vector mode, you program the iris closed and open as before. Then you set the cross-fade time to 0 and program a slow speed, in the second scene, on the Effect Speed Channel.

# ANIMATION GUIDE

This chapter is designed to help you get as much as possible from the gobo animation system in your MAC 2000 Performance II. It contains a section on general animation tips, an overview of the animation disc designs available, and a number of examples of different effects that can easily be created using your animation system.

To achieve most of the effects you will use both an animation disc and a regular gobo. Throughout this guide we have used DHA Lighting in the United Kingdom as the reference for the regular gobos. All of the gobo numbers and designs mentioned belong to the standard range available from DHA Lighting. Their contact details are:

DHA Lighting Limited  
284-302, Waterloo Road  
London, SE1 8RQ  
United Kingdom  
  
Tel: +44 207 771 2900  
Fax: +44 207 771 2901  
  
Internet: [www.dhalighting.co.uk](http://www.dhalighting.co.uk)  
E-mail: [sales@dhalighting.co.uk](mailto:sales@dhalighting.co.uk)

Martin Professional A/S are extremely grateful to DHA Lighting for allowing us to use material previously published by them.

Note that there may be some small differences between the graphical images that you see in this guide and the final animation wheel or gobo designs when you use them, due to the difference in scale. However, we have tried to be as accurate as possible.

## General animation tips

Via your DMX controller, you can control both the starting position of the animation disc and its rotation direction and speed. The animation disc can be set to run continuously or to run in an indexing mode, which will be of great use if you are using custom animation discs with text or company logos. You are also able to choose the angle at which the disc has its starting position, be it horizontally aligned, vertically aligned, or anywhere in between.

### Choice of gobo

The gobo is the basis of the moving image and should be chosen first. It is worth noting, however, that useful and interesting effects can often be achieved with the most unlikely gobos, by projecting them out of focus.

### Focus

With the gobo in hard focus the animation will not be optimized, movement is minimal and results will almost always be disappointing. Similarly with the animation disk in hard focus, you will see a far greater movement, but the gobo pattern will be lost. It is essential therefore to experiment with the focus in order to achieve the best effect. The precise quality of the result and the impression of the motions direction will also depend on the position of the focus.

### Animation disc patterns

“Effects ideas” on page 24 describes the variations on the basic effect that individual disc patterns can produce.

### Direction of movement

The flexible mounting system for the animation discs inside the MAC 2000 Performance II allow you, through DMX control, to position the wheel at any position through a 90 degree section of the disc. This means that effects can be produced with a horizontal movement - such as clouds, with a vertical movement - such as rising flames, or at any angle in between - such as driving rain. The angle of the rotation can be changed during your show via the DMX control of the fixture.

Note that for some animation effects, which are not strictly horizontal or vertical, you may find it necessary to flip the orientation of the complete head via the pan and tilt control channels to give your desired angle of animation. This will

depend on the orientation of the head when you began programming your fixture. If you find, for example, that your 'driving rain' effect is not driving the correct way, flip the orientation and if necessary, rotate the animation wheel in the opposite direction.

Through the DMX control you can select the wheel to operate in indexing mode, rather than continuously rotating. This is useful for any custom animation wheels that you may have made with text or logos. Custom animation wheels are available from the major gobo manufacturers, such as DHA Lighting in London.

## Speed

The apparent speed of image movement depends not only on the disc rotation speed, but on the complexity of both the gobo and the disc patterns. Speeds suggested in the examples in this handbook are guidelines and are only intended as a starting point.

## Color

The use of the dichroic CMY color changing system of the MAC 2000 Performance II can greatly enhance your animation effects. The system has been designed so that refraction across the beam will give slight variants in color, adding depth to your animations, particularly when using multiple dichroic colors. Some color tips are given in the 'EFFECTS IDEAS' section.

## Animation discs and their uses

Five gobo animation wheels are supplied as standard with the MAC 2000 Performance II. The others mentioned here can be ordered from your Martin dealer.

### Tangential breakup

The Tangential Breakup disc (P/N 62400215) produces a subtle rippling motion, particularly when moving parallel with the lines of the gobo. It is the most suitable for rising flames, flowing water and other effects where a single direction of movement is required.

This animation wheel is supplied as standard with your MAC 2000 Performance II.



### Radial breakup

The Radial Breakup disc (P/N 62400211) is perfect for providing a strong regular movement suitable for flickering flames, water ripples, reflected water and shimmers for heat haze or mirage effects.

This animation wheel is supplied as standard with the MAC 2000 Performance II.

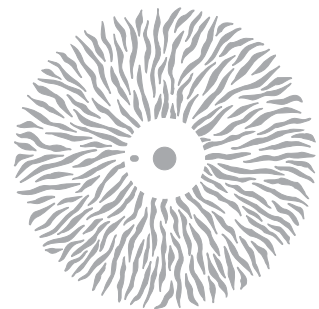

### Spiral breakup

The Spiral Breakup disc (P/N 62400216) pattern is very similar to the Radial Breakup disc, but has some movement at right angles to the main motion, as is seen in wind blown rain, snow, or flames. It is particularly worth experimenting with the angle of the gobo and the orientation of the disc to achieve all the possibilities with this pattern.

This animation wheel is supplied as standard with the MAC 2000 Performance II.

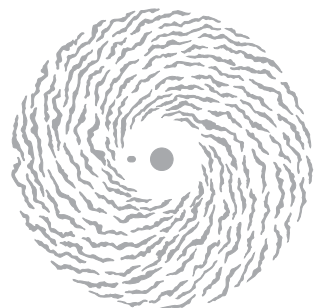

## Linear breakup

The Linear Breakup disc (P/N 62400223) provides rhythmic movement and can be used to simulate a breeze through the branches of a tree or the rhythmic undulations of sea waves.

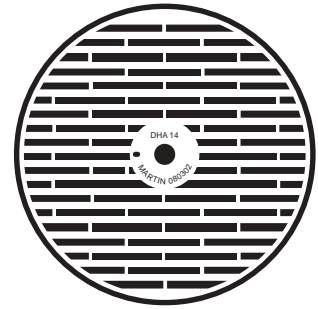

## Triangle breakup

The Triangle Breakup disc (P/N 62400225) gives a more pronounced and rapid rhythmic effect than the Linear Breakup disc, and is suitable for use as psychedelic effects or for a rough sea effect.



## Cloud breakup

The Cloud Breakup disc (P/N 62400213) is designed for a softer directional movement particularly at slow or very slow speeds. It is suitable for cloud effects with cloud gobos or for a soft slow-flowing stream effect.

This animation wheel is supplied as standard with the MAC 2000 Performance II.

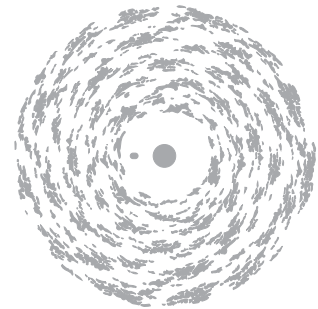

## Elliptical breakup

The Elliptical Breakup disc (P/N 62400221) produces a bidirectional movement similar to the Spiral Breakup, but with constantly changing direction of movement. This is specifically useful for snow or similar effects where flurries of movement would be expected.



## Dot breakup

The Dot Breakup disc (P/N 62400214) gives you the opportunity to cause motion while maintaining a more focused projection of the gobo image. It is suggested for effects such as falling leaves or rising bubbles.

This animation wheel is supplied as standard with the MAC 2000 Performance II.

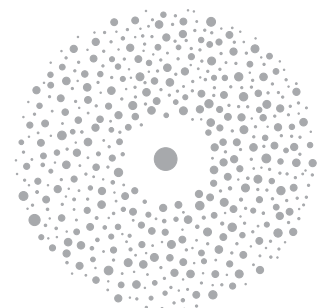

## Flicker wheel

The Flicker Wheel (P/N 62400222) provides a different kind of effect and can be used at high speed for motion effects, such as passing trains. It can also be effectively used for just breaking up the beam of a fixture and for an organic strobe effect.

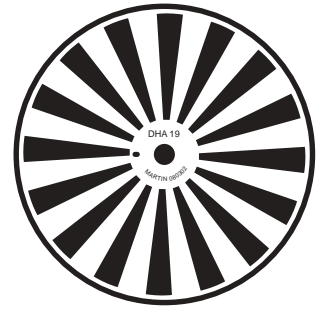

## Coarse radial breakup

The Coarse Radial Breakup disc (P/N 62400224) is particularly effective for animating light from a non-focused source whilst providing a minimal loss in intensity due to the high 'white to black' ratio of the radial pattern. It is also effective for similar uses to the Radial Breakup disc.

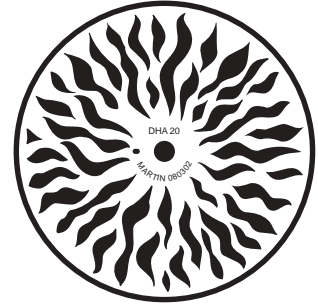

## Coarse tangential breakup

The Coarse Tangential Breakup disc (P/N 62400226) can be used on its own in an unfocused form to give the image of flames. It can also be combined with gobos to give a drifting image to the projection.



## Effects ideas

The ideas outlined here are intended as suggestions only. The precise look of any effect will depend on many factors including the focus setting of your MAC 2000 Performance II, the projection surface onto which the image is directed and any color mixing effects that you choose.

This section is divided into four:

- “Water effects” on page 25
- “Fire effects” on page 27
- “Clouds, rain and snow” on page 28
- “Other effects” on page 29



## Water effects

### RIPPLING WATER

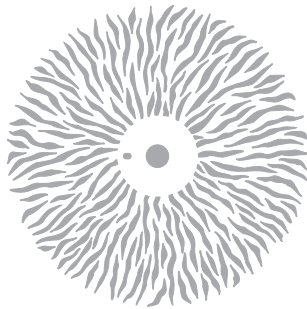

Radial breakup disc

and one of the following

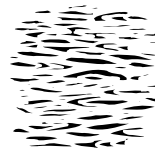

Gobo 955

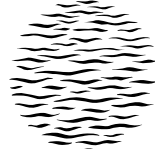

Gobo 958



Gobo 833

Use slower speeds for gentler or more distant movement. For rough water, substitute a more 'wavy' gobo design such as DHA Lighting's 'Reflected Water 906', 'Flames-4 960', or 'Fire/Waves 238-275' and use the Coarse Radial Breakup animation disc or the Elliptical Breakup animation disc (for an irregular movement) combined with a higher rotation speed.

#### Alternative gobos:

Linear Breakups 401, 402, 501, 504

Shower 882

#### Alternative animation discs:

Coarse Radial Breakup gives a bolder movement

Spiral Breakup adds some flowing movement

### WAVES



Triangle breakup disc

and one of the following



Gobo 504



Gobo 238-275

As with any animation effect, the rotation speed and image focus will have a great effect on the final projection, so these parameters should be experimented with. With all water effects, it is possible to add an amount of cyan from the color mixing system, which will diffract to give both cyan and white color shifts as the image animates.

#### Alternative gobos:

Linear Breakups 401, 402, 501, 504

Reflected Water 906

#### Alternative animation discs:

Linear Breakup

Elliptical Breakup gives an irregular rhythm

## REFLECTED WATER

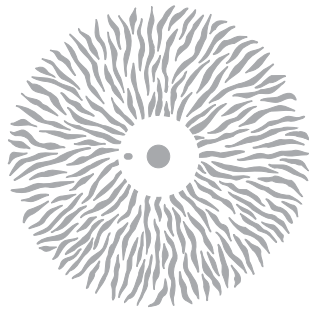

**Radial breakup disc**

and one of the following



**Gobo 903**

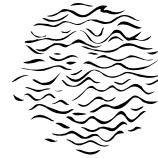

**Gobo 906**

As with any animation effect, the rotation speed and image focus will have a great effect on the final projection, so these parameters should be experimented with. With all water effects, it is possible to add an amount of cyan from the color mixing system, which will diffract to give both cyan and white color shifts as the image animates.

### Alternative animation disc:

Elliptical Breakup gives an irregular movement

## WHIRLPOOL



**Spiral breakup disc**

and



**Gobo 893**

A whirlpool effect can be created effectively by leaving the gobo in a static position and just rotating the animation wheel. However, to give a more dynamic whirlpool effect, the gobo for this combination should also be rotated, in a counter direction to the animation wheel. Again differences in the focus and in particular with the speeds on this effect will give you a variety of different options. With all water effects, it is possible to add an amount of cyan from the color mixing system, which will diffract to give both cyan and white color shifts as the image animates.

## FLOWING WATER



**Tangential breakup disc**

and one of the following

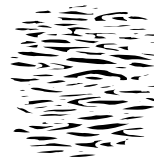

**Gobo 955**

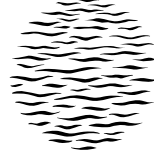

**Gobo 958**

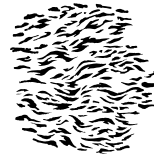

**Gobo 960**

As with any animation effect, the rotation speed and image focus will have a great effect on the final projection, so these parameters should be experimented with. With all water effects, it is possible to add an amount of cyan from the color mixing system, which will diffract to give both cyan and white color shifts as the image animates.

## Fire effects

The range of animation wheels available for the MAC 2000 Performance II is very versatile in producing fire and flame effects. Good results may be obtained from many of the designs together with any standard flame or fire gobo designs.

Here are a few ideas to get you started:

### BLOWING FLAMES

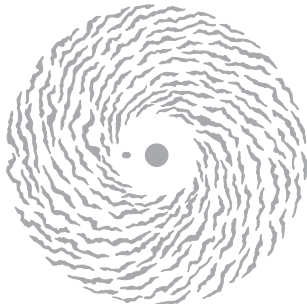

**Spiral breakup disc**

and one of the following



**Gobo 176**



**Gobo 175**

As with any animation effect, the rotation speed and image focus will have a great effect on the final projection, so these parameters should be experimented with. With all fire and flame effects, it is possible to add an amount of magenta (approximately 70%) and yellow (approximately 90%) from the color mixing system, which will diffract to give orange, yellow and red color shifts as the image animates.

#### Alternative gobos:

Any of the fire or flame gobos from the standard range could be used in substitution for the above suggestions.

#### Alternative animation discs:

Elliptical Breakup gives an irregular movement

Dot Breakup

### RISING FLAMES 1



**Tangential breakup disc**

and one of the following



**Gobo 176**



**Gobo 175**

As with any animation effect, the rotation speed and image focus will have a great effect on the final projection, so these parameters should be experimented with. With all fire and flame effects, it is possible to add an amount of magenta (approximately 70%) and yellow (approximately 90%) from the color mixing system, which will diffract to give orange, yellow and red color shifts as the image animates.

#### Alternative gobos:

Any of the fire or flame gobos from the standard range could be used in substitution for the above suggestions.

## RISING FLAMES 2



### Coarse tangential breakup disc

Different to above, this animation gives a much stronger image of rising flames with the broader pattern on the disc. For this animation, it is possible to use the animation disk on its own to create the rising flame effect. You will need to set the focus away from the disk itself to enhance the effect. To give a different image, you could also add one of the standard fire or flame gobo designs.

#### Alternative gobos:

Any of the fire or flame gobos from the standard range can be used.

## Clouds, rain and snow

The versatility that you can achieve with the animation system of the MAC 2000 Performance II makes this an ideal tool for creating all sorts of weather effects.

### CLOUDS

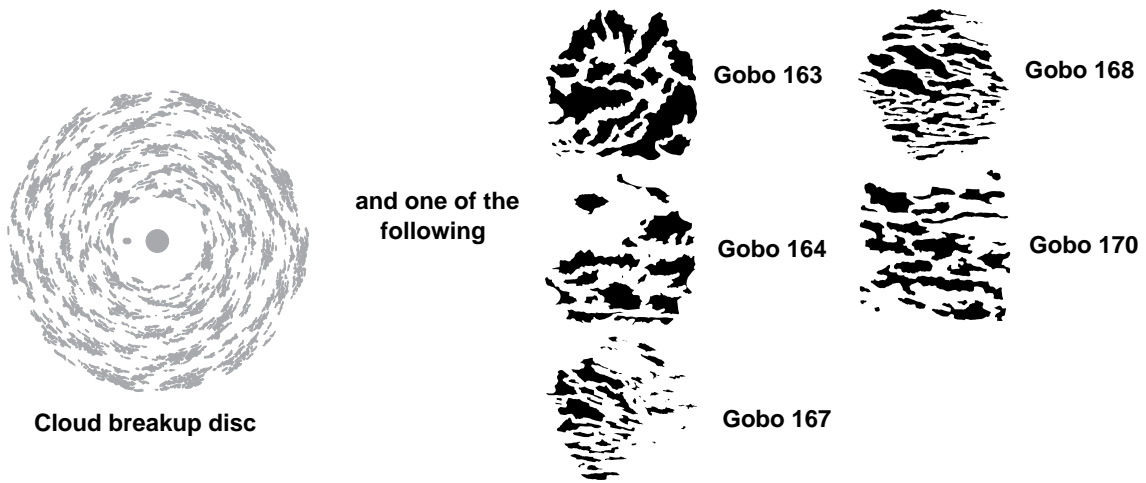

Cloud breakup disc

Gobo 163

Gobo 168

Gobo 164

Gobo 170

Gobo 167

Once again, the speed and focus come greatly into play when creating your final effect, whether you wish to create soft flowing clouds on a summers night or gathering thunder clouds about to explode.

#### Alternative gobos:

Use any non-meshed cloud gobo to create the desired effect that you need. You should choose your gobo based on the type and density of your desired effect.

## RAIN



**Spiral breakup disc**

and one of the following

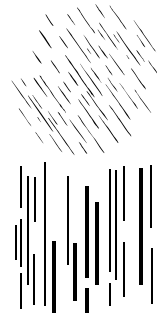

**Gobo 882**

**Gobo 503**

For driving rain, you should angle the gobo first using the indexing control and then align the animation wheel anywhere between the horizontal and vertical axis to provide the desired effect.

## SNOW



**Elliptical breakup disc**

and

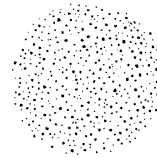

**Gobo 884**

This is a simple effect to set up, but looks excellent. The use of the prism on the effect wheel of the MAC 2000 Performance II will help diffuse the image, creating a more random effect, which adds a new dimension to the animation and is very effective in some situations.

## Other effects

Here are some further examples of different animations that can be achieved with the MAC 2000 Performance II.

### LIGHT THROUGH TREES



**Elliptical breakup disc**

and



**Gobo 405**

It is possible to use almost any of the animation discs to animate a breakup gobo such as this one. There is a wide range of breakup gobos available to choose from on the market today.

By using a combination of the cyan and yellow color mixing flags, you can create various shades of green which will diffract to give a variety of shades. You should adjust the values proportionately to give darker or lighter shades of green to your image.

**TREE IN BREEZE**



**Linear breakup disc**

and



**Gobo 110**

By using a combination of the cyan and yellow color mixing flags, you can create various shades of green which will diffract to give a variety of shades. You should adjust the values proportionately to give darker or lighter shades of green to your image.

**Alternative gobos:**

There are a wide range of tree, branch and foliage gobos available which can all be animated to give very distinctive effects.

**PASSING TRAIN**

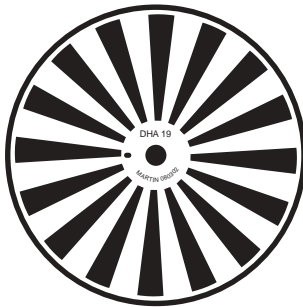

**Flicker wheel**

and one of the following

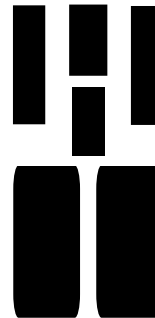

**Gobo 901**

**Gobo 902**

Adjusting the rotation speed of the animation wheel will give you a faster or slower 'flicker' effect depending on the speed of your train.

# OPTICAL CONFIGURATION

## Rotating gobo wheel

The MAC 2000 Performance II is supplied with 5 rotating gobos installed. Figure 11 shows the standard gobo configuration with the gobo positions marked.

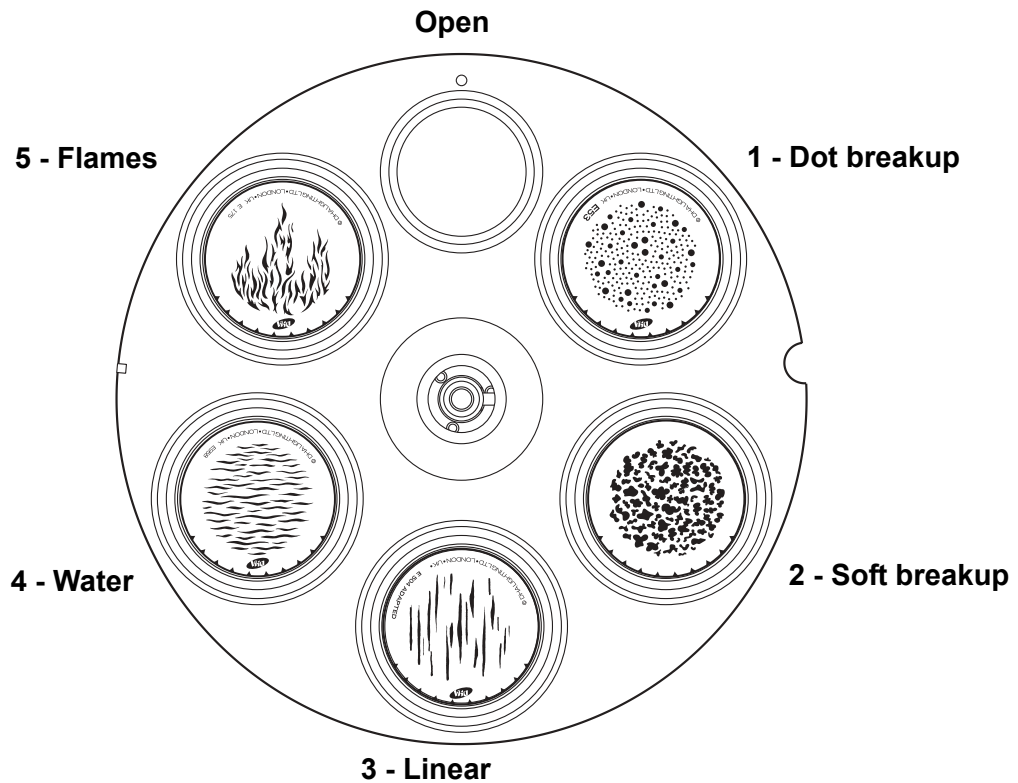
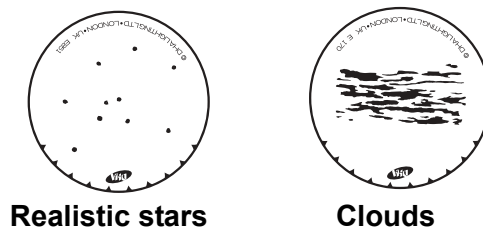

Figure 11: Standard rotating gobo wheel configuration as seen from lamp

The rotating gobos are magnetically indexed with a special indexing gobo holder in position 2 (the Soft Breakup gobo). The indexing gobo holder, which has a small magnet, must always be in position 2. If it is placed in a different position, the gobos will not index correctly. The indexing gobo holder accepts the same gobos as normal holders; any gobo suitable for the MAC 2000 may be placed in position 2.

Two additional aluminum gobos are supplied.



## Gobo specifications

All gobo slots accept round theatrical size-E glass gobos. The rotating-gobo wheel positions hold gobos up to 3 mm thick with the gobo retention spring. Gobos thicker than 3 mm must be glued in the holder.

For the best results, custom glass gobos that meet the following criteria should be used:

Outside diameter: . . . . .37.5 +0/-0.3 mm (1 15/32 +0/-0.01 in.)  
Maximum image diameter: . . . . .30 mm (1 3/16 in.)  
Material: . . . . .High temperature Borofloat or better glass  
Coating: . . . . .Dichroic or enhanced aluminum

Although glass gobos are generally the most durable, satisfactory results can be obtained in many applications at less expense with aluminum gobos. Our experience with the MAC 2000 Performance II, which is supplied with aluminum gobos, shows that aluminum can hold up to the heat very well. Custom stainless steel gobos can also be used, however they can warp, losing sharpness, in a matter of hours in the MAC 2000 Performance II. The useful life will depend on the gobo pattern and the projection cycle. Consult your gobo supplier for more information.

## Orientation

### GLASS GOBOS

Coated glass gobos are inserted with the coating against the rim of the holder (away from the spring). Textured gobos are inserted with the smooth side against the spring. This provides the best results when combining rotating gobos.

**Coated side**

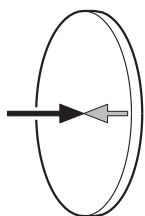

When an object is held up to the coated side there is no space between the object and its reflection. The back edge of the gobo cannot be seen when looking through the coated side.

**Uncoated side**

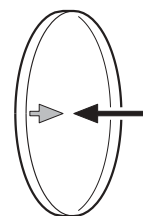

When an object is held up to the uncoated side there is a space between the object and its reflection. The back edge of the gobo can be seen when looking through the uncoated side.

**Figure 12: Finding the coated side**

### METAL GOBOS

For correct projection, install metal custom gobos with the true image facing the lamp. The false-image side (which faces away from the lamp) should be coated with a suitable high-temperature black paint to reduce reflections.



## Replacing rotating gobos

**Important!** *The gobo can fall out if the spring is inserted backwards.*

- 1 Disconnect the fixture from power and allow it to cool.
- 2 Lock the head in the top side up position and remove the top cover. Turn the gobo wheels as required to access the desired position. Pull the gobo holder away from the wheel slightly to release. Remove the gobo holder.

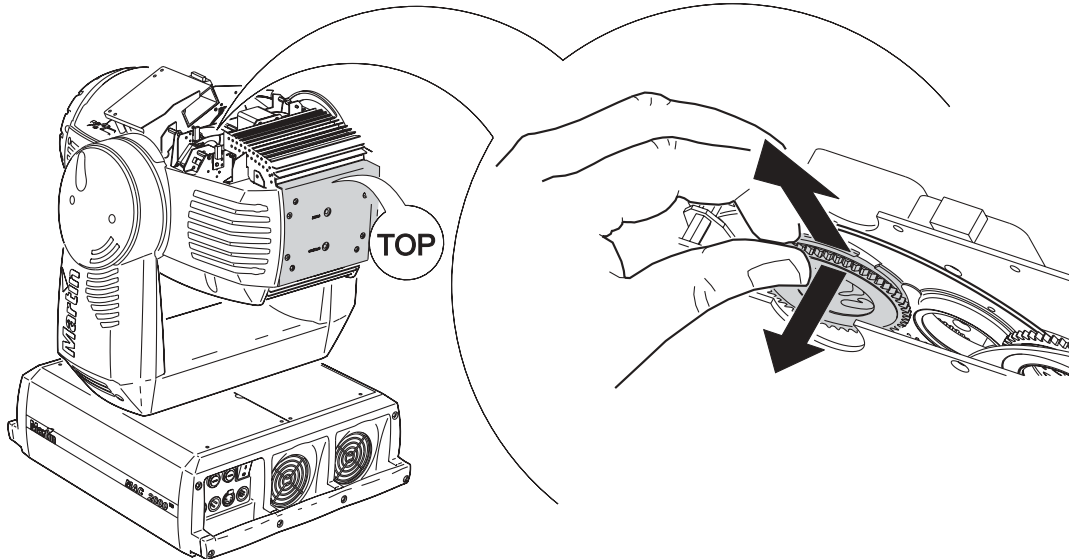

- 3 Remove the gobo retention spring from the gobo holder and drop the gobo out of the holder. Insert the new gobo in the holder. *Insert the spring with the narrow end against the gobo.* To identify the narrow end, press the spring flat: the narrow end is on the inside. Push the end of the spring in under the lip of the holder.

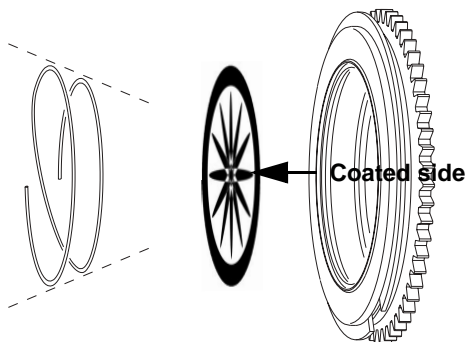

- 4 Work the rim of the gobo holder under both clips and snap the gobo holder back into position. If necessary, a small screwdriver or similar tool may be used to pry the clips away from the wheel.
- 5 Replace the cover and release the pan and/or tilt locks before operating.

## Effect wheel

The effect wheel provides a variable frost filter and two positions for effects. The MAC 2000 Performance II comes with a wide angle lens and a nine-facet prism installed in these positions.

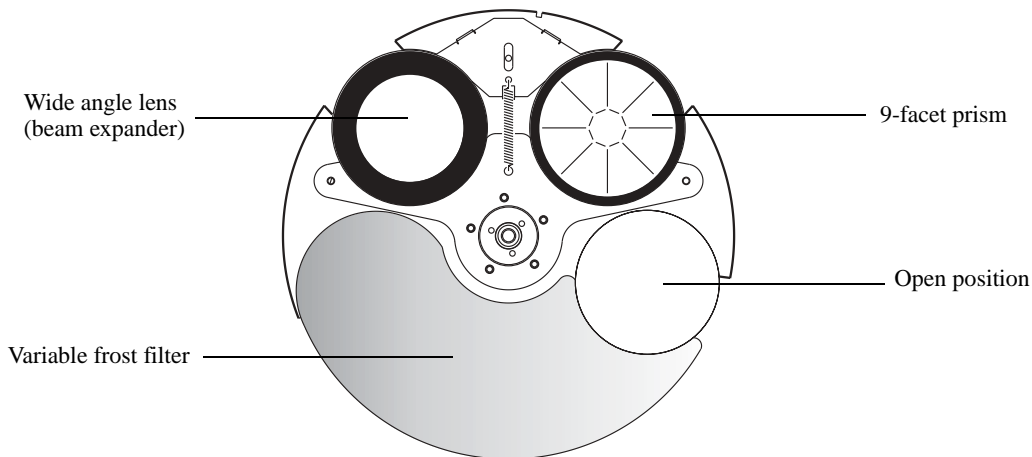

## Replacing effects

- 1 Disconnect the fixture from power and allow it to cool.
- 2 Lock the head in the upside down position and remove the bottom cover. Turn the effect wheel so that the locking plate is under the sensor bracket.
- 3 To remove, hold the rim of the effect holder and pull back on the locking plate. Remove effect from wheel.
- 4 To insert, pull back on the locking plate. If both effects are removed, pull straight back on both tabs. Position the groove in the effect holder over the fixed plate. Release the locking plate and verify that the effect is properly seated.
- 5 Replace the bottom cover and unlock the head before operating.

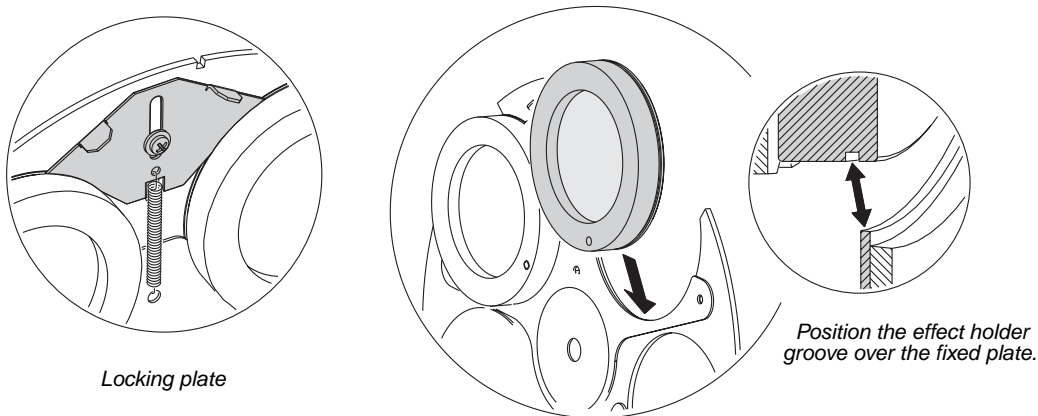

## Gobo animation

The following gobo animation wheel patterns are supplied with the MAC 2000 Performance II.

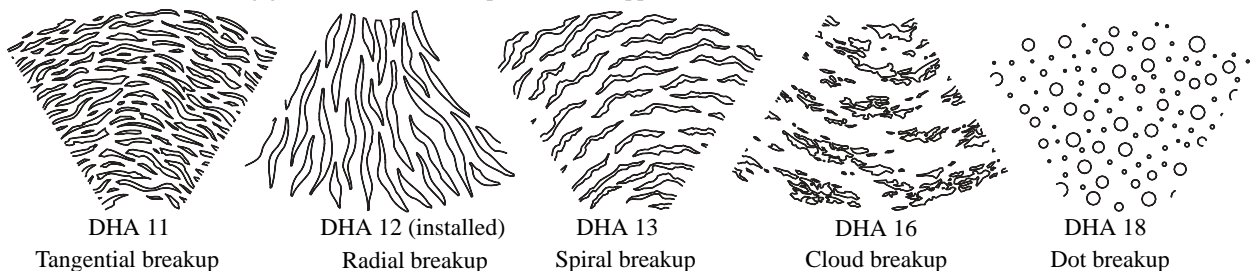

For information about using the gobo animation effects, see “Animation guide” on page 21.

## Replacing the gobo animation wheel

- 1 Disconnect the fixture from power and allow it to cool.
- 2 Lock the head in the upside down position and remove the bottom cover.
- 3 Using a finger or thumb (as illustrated), move the installed animation wheel up.

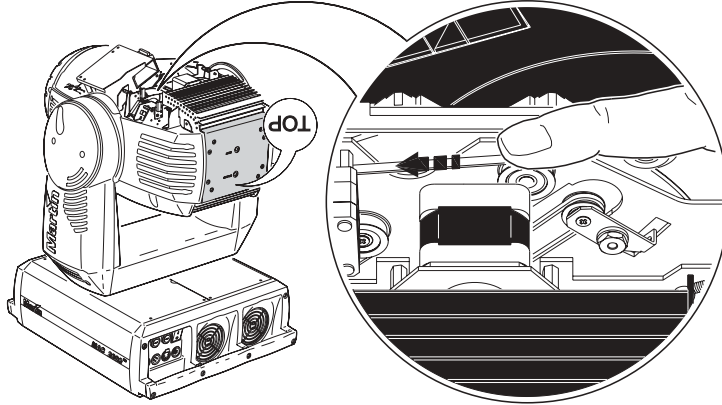

- 4 The animation wheels are made of thin aluminum, so use a screw driver to release the wheel from the magnetic mount.

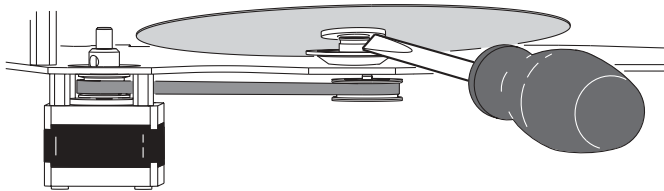

- 5 Take the wheel out by hand.

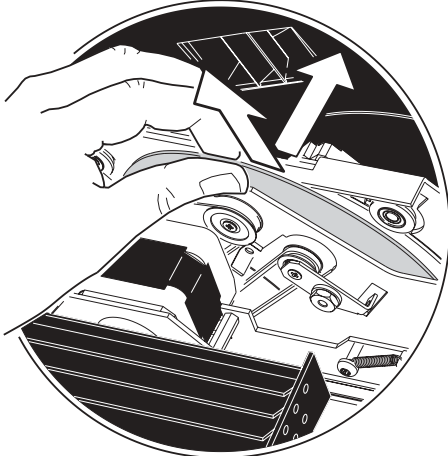

- 6 To insert a new wheel, place it over the mount, ensuring that the magnet that is fitted to the animation wheel is facing the mount. There is a small indexing position hole in each animation wheel and the indexing pin on the mount must be positioned in this hole.
- 7 Replace the bottom cover and unlock the head before operating

# ROUTINE MAINTENANCE

The MAC 2000 Performance II requires routine cleaning. The schedule depends heavily on the operating environment; please consult a Martin service technician for recommendations.

Refer all service not described here to a qualified Martin technician.

**Important!** *Excessive dust, smoke fluid, and particulate buildup degrades performance and causes overheating and damage to the fixture that is not covered by the warranty.*

**Warning!** *Disconnect the fixture from power before removing any cover.*

## Cleaning

Use care when cleaning optical components and work in a clean, well lit area. The coated surfaces are fragile and easily scratched. Do not use solvents that can damage plastic or painted surfaces.

Inspect the air filters regularly and clean before they become clogged. Replace the air filters with new ones when replacing the lamp.

To maintain adequate cooling, dust must be cleaned from the fans and air vents periodically.

### Cleaning optical components

- 1 Disconnect the fixture from power and allow the components to cool completely. Remove the head cover.
- 2 Vacuum or gently blow away dust and loose particles with compressed air.
- 3 Remove stuck particles with an unscented tissue or cotton swab moistened with glass cleaner or distilled water. Do not rub the surface: lift the particles off with a soft repeated press.
- 4 Remove smoke and other residues with cotton swabs or unscented tissues moistened with isopropyl alcohol. A commercial glass cleaner may be used, but residues must be removed with distilled water. Clean with a slow circular motion from center to edge. Dry with a clean, soft and lint-free cloth or compressed air.

### Cleaning the fan and air vents

Remove dust from the fans and air vents with a soft brush, cotton swab, vacuum, or compressed air.

### Cleaning or replacing the air filters

- 1 Disconnect the fixture from power. On each side of the head, remove the 2 screws that hold the side cover using a Torx-20 screwdriver. Slide the cover forward to remove. Lift the filter off of the cover.
- 2 Clean the filters with a vacuum or compressed air, or replace them. If they are saturated with smoke fluid, etcetera, soak them in warm soapy water and blot dry.
- 3 Place the filters on the covers and replace the covers.

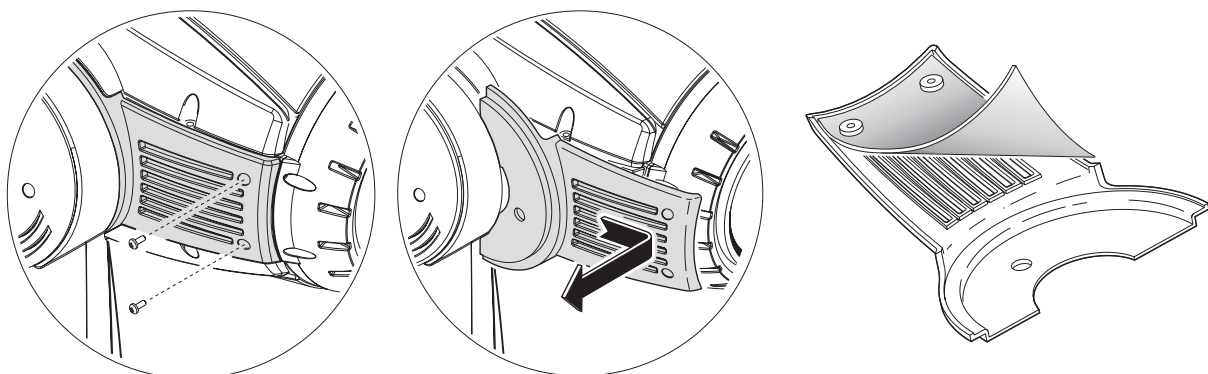

# Software installation

Software updates are installed in the MAC 2000 Performance II using a Martin MP-2 Uploader or a LightJockey 4064 DMX interface card. The procedure is found in the MP-2 user manual and the Martin Software Uploader online help file.

## Requirements

The following are required in order to install software.

- The MAC 2000 Performance II update file, available for download from the User Support Area of the Martin web site (<http://www.martin.dk>).
- The Martin Software Uploader program, version 4.0 or later, available for download from the User Support Area of the Martin web site.
- A Martin MP-2 Uploader connected to a Windows 95/98/ME/2000/XP PC, or a LightJockey Controller (DJ or Club) with 4064 DMX Interface card.

## Preventing software updates

Software updates are enabled by default, but you can disable this by setting the Write jumper (see “Circuit board connections” on page 54) to disable.

## Boot sector jumper

If the normal upload procedure does not work, or if the software update notes call for a boot sector update, move the boot sector jumper on the printed circuit board to the BOOT position before uploading software.

### SETTING THE BOOT SECTOR JUMPER

- 1 Disconnect the fixture from power.
- 2 Remove the top screws from the ends of the front side panel and tilt the panel down to expose the main circuit board.
- 3 Using the appropriate diagram in “Circuit board connections” on page 54 or the label inside the base, locate the BOOT jumper (PL16). Move the jumper to the “BOOT” position.
- 4 Perform a boot mode upload. When the upload is complete, disconnect the fixture from power and move the jumper back to the locked or normal position.

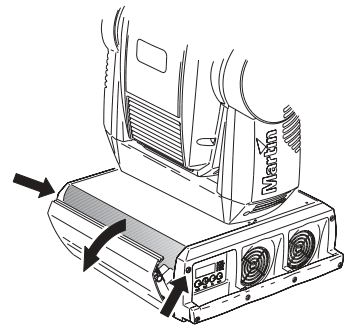

# DMX PROTOCOL

This section contains two DMX protocols (both from protocol version 1.0A):

- “16-bit protocol” on page 39
- “8-bit protocol” on page 42

The 16-bit is the default protocol that is used. To modify this use the control menu. For more information see “Control menu” on page 45.

# 16-bit protocol

DMX channel	Value	Percent	Function	Start code = 0	
1	0 - 19	0 - 7	<b>Shutter, Strobe, Reset, Lamp On/Off</b> Shutter Closed (lamp reduced to 700 W (E-ballast) after 10 sec.)		
	20 - 49	8 - 19	No function (Shutter Open)		
	50 - 72	20 - 28	Strobe on fast->slow		
	73 - 79	29 - 31	Shutter open, lamp reduced to 700 W (E-ballast)		
	80 - 99	32 - 39	Pulse opening fast ->slow		
	100 - 119	40 - 47	Pulse closing fast ->slow		
	120 - 127	48 - 50	No function		
	128 - 147	51 - 57	Random Strobe Fast		
	148 - 167	58 - 65	Random Strobe Medium		
	168 - 187	66 - 73	Random Strobe Slow		
	188 - 190	74 - 74	No function		
	191 - 193	75	Random pulse opening fast		
	194 - 196	76	Random pulse opening slow		
	197 - 199	77	Random pulse closing fast		
	200 - 202	78 - 79	Random pulse closing slow		
	203 - 207	80 - 81	No function		
	208 - 217	82 - 85	Reset Fixture		
	218 - 227	86 - 89	No function		
	228 - 237	90 - 93	Lamp On (Power On)		
	238 - 247	94 - 97	No Function		
	248 - 255	98 - 100	Lamp Off (Power Off) <b>Note:</b> T > 5 seconds		
	2	0 - 255	0 - 100	<b>Intensity</b> 0 – 100%	
	3	0 - 255	0 - 100	<b>Cyan</b> White -> Cyan	
	4	0 – 255	0 - 100	<b>Magenta</b> White -> Magenta	
5	0 – 255	0 - 100	<b>Yellow</b> White -> Yellow		
6	0 – 255	0 - 100	<b>CTC</b> White -> CTC		
7	0 – 9	0 - 3	<b>Rotating gobo 1 selection</b> Open gobo		
	10 – 14	4 - 5	Gobo 1 – Indexing (set index on channel 8)		
	15 – 19	6 - 7	Gobo 2 – Indexing (set index on channel 8)		
	20 – 24	8 - 9	Gobo 3 – Indexing (set index on channel 8)		
	25 – 29	10 - 11	Gobo 4 – Indexing (set index on channel 8)		
	30 – 34	12 - 13	Gobo 5 – Indexing (set index on channel 8)		
	35 – 39	14 - 15	Gobo 1 – Cont. Rotation (set dir/speed on channel 8)		
	40 – 44	16 - 17	Gobo 2 – Cont. Rotation (set dir/speed on channel 8)		
	45 – 49	18 - 19	Gobo 3 – Cont. Rotation (set dir/speed on channel 8)		
	50 – 54	20 - 21	Gobo 4 – Cont. Rotation (set dir/speed on channel 8)		
	55 – 59	22 - 23	Gobo 5 – Cont. Rotation (set dir/speed on channel 8)		
	60 – 74	24 - 29	<b>Gobo shake (indexing)</b> Gobo 1 slow -> fast		
	75 – 89	30 - 35	Gobo 2 slow -> fast		
	90 – 104	36 - 41	Gobo 3 slow -> fast		
	105 – 119	42 - 46	Gobo 4 slow -> fast		
	120 – 134	47 - 52	Gobo 5 slow -> fast		
	135 – 149	53 - 58	<b>Gobo shake (continuous gobo rotation)</b> Gobo 1 slow -> fast		
	150 – 164	59 - 64	Gobo 2 slow -> fast		
	165 – 179	65 - 70	Gobo 3 slow -> fast		
	180 – 194	71 - 67	Gobo 4 slow -> fast		
	195 – 209	77 - 82	Gobo 5 slow -> fast		
	210 – 232	83 - 91	<b>Gobo wheel continuous rotation (continuous gobo rotation)</b> CW slow -> fast		
	233 – 255	92 - 100	CCW fast -> slow		

DMX channel	Value	Percent	Function	Start code = 0
8	0 – 255	0 - 100	<b>Rotating gobo 1 index coarse, MSB</b> (Set gobo selection on channel 7) Index min. -> max	
	0 – 2	0	<b>Rotating gobo 1 cont. rotation</b> (Set gobo selection on channel 7) Static	
	3 – 127	1 - 50	CCW slow -> fast	
	128 – 252	51 - 99	CW fast -> slow	
	253 – 255	100	Static	
9	0 – 255	0 - 100	<b>Rotating gobo 1 index fine, LSB</b> (Set gobo selection on channel 7) Index min. -> max	
	0 – 255	0 - 100	<b>Rotating gobo 1 cont. rotation</b> (Set gobo selection on channel 7) No function	
10	0 – 9	0 - 3	<b>Gobo Animation wheel position</b> No Effect	
	10 – 19	4 - 7	Vertical position – Indexing (set index on channel 10)	
	20 – 29	8 - 11	Horizontal position – Indexing (set index on channel 10)	
	30 – 39	12 - 15	Vertical position – Cont. Rotation (set dir/speed on channel 10)	
	40 – 49	16 - 19	Horizontal position – Cont. Rotation (set dir/speed on channel 10)	
	50 – 139	20 - 54	Animation wheel scroll position (Vertical -> Horizontal) – Indexing (set index on channel 11)	
	140 – 229	55 - 89	Animation wheel scroll position (Horizontal -> Vertical) – Cont. Rot. (set dir/speed on channel 11)	
	230 – 235	90 - 92	No Effect	
	236 – 239	93	<b>Gobo Animation MACROS</b> Macro 1	
	240 – 243	94 - 95	Macro 2	
244 – 247	96	Macro 3		
248 – 251	97 - 98	Macro 4		
252 – 255	99 - 100	Macro 5		
11	0 – 255	0 - 100	<b>Gobo Animation wheel index</b> (Set position on channel 10) Index min. -> max	
	0 – 2	0	<b>Gobo Animation wheel cont. rotation</b> (Set position on channel 10) Static	
	3 – 127	1 - 50	CCW slow -> fast	
	128 – 252	51 - 99	CW fast -> slow	
	253 – 255	100	Static	
12	0	0	<b>Effect selection</b> Open	
	1 – 234	1 - 91	Variable Frost min. -> max.	
	235 – 242	92 - 95	Effect 1	
	243 – 250	96 - 98	Effect 2	
	251 – 255	99 - 100	Open	
13	0 – 199	0 - 77	<b>Iris</b> Open -> close	
	200 – 215	78 - 84	Close	
	216 – 229	85 - 89	Pulse opening fast -> slow	
	230 – 243	90 - 94	Pulse closing fast -> slow	
	244 – 246	95 - 96	Random pulse opening fast	
	247 – 249	97	Random pulse opening slow	
	250 – 252	98 - 99	Random pulse closing fast	
	253 – 255	100	Random pulse closing slow	
14	0 – 2	0 - 1	<b>Framing MACRO functions</b> No Macro	
	3 – 255	2 - 100	Reserved for MACROs	
15	0 - 255	0 - 100	<b>Focus</b> Focus far -> near	
16	0 – 255	0 - 100	<b>Zoom</b> Zoom wide -> narrow	
17	0 – 255	0 - 100	<b>Framing shutter 1</b> Out -> In	
18	0 – 126	0 - 49	<b>Framing shutter 1</b> Angle –	
	127 - 128	50	Parallel	
	129 – 255	51 - 100	Angle +	
19	0 – 255	0 - 100	<b>Framing shutter 2</b> Out -> In	



DMX channel	Value	Percent	Function	Start code = 0
20	0 – 126 127-128 129 – 255	0 50 100	<b>Framing shutter 2</b> Angle – Parallel Angle +	
21	0 – 255	0 - 100	<b>Framing shutter 3</b> Out -> In	
22	0 – 126 127 - 128 129 – 255	0 50 100	<b>Framing shutter 3</b> Angle – Parallel Angle +	
23	0 – 255	0 - 100	<b>Framing shutter 4</b> Out -> In	
24	0 – 126 127 - 128 129 – 255	0 50 100	<b>Framing shutter 4</b> Angle – Parallel Angle +	
25	0 – 255	0 - 100	<b>Rotate framing shutters</b> Right -> Center -> Left	
26	0 127 255	0 50 100	<b>Pan coarse</b> Max Left Neutral Max Right	
27	0 127 255	0 50 100	<b>Pan fine</b> Max Left Neutral Max Right	
28	0 127 255	0 50 100	<b>Tilt coarse</b> Max Up Neutral Max Down	
29	0 127 255	0 50 100	<b>Tilt fine</b> Max Up Neutral Max Down	
30	0 - 2 3 – 236 237 – 239 240 – 242 243 – 245 246 – 248 249 – 251 252 – 255	0 - 1 2 - 92 93 94 95 96 - 97 98 99 - 100	<b>Speed: Pan/Tilt Movement</b> Tracking Speed Fast -> Slow Tracking (Slow speed - Overriding the PTSP menu setting) Tracking (Normal speed - Overriding the PTSP menu setting) Tracking (Fast speed - Overriding the PTSP menu setting) Fan speed (Regulation, min. noise level – Overriding the FAN menu setting) Fan speed (Full speed, max. cooling – Overriding the FAN menu setting) Blackout while moving	
31	0 – 2 3 – 239 240 – 242 243 – 245 246 – 248 249 – 251 252 – 255	0 1 - 93 94 - 95 96 97 - 98 99 100	<b>Speed: Dimmer, Cyan, Magenta, Yellow, CTC, Effect, Iris, Focus, Zoom</b> Tracking Speed Fast -> Slow Tracking (Studio mode disabled – Overriding the MOfE menu setting) Tracking (Studio mode enabled – Overriding the MOfE menu setting) Tracking (Shortcuts disabled - Overriding the SCUT menu setting) Tracking (Shortcuts enabled - Overriding the SCUT menu setting) Fast Speed	
	0 – 2 3 – 239 240 – 242 243 – 245 246 – 248 249 – 251 252 – 255	0 1 - 93 94 - 95 96 97 - 98 99 100	<b>Speed: Gobo 1, Framing, Animation wheel pos., Animation wheel rot.</b> Tracking Speed Fast -> Slow Tracking (Studio mode disabled – Overriding the MOfE menu setting) Tracking (Studio mode enabled – Overriding the MOfE menu setting) Tracking (Shortcuts disabled - Overriding the SCUT menu setting) Tracking (Shortcuts enabled - Overriding the SCUT menu setting) Blackout while moving	

## 8-bit protocol

DMX channel	Value	Percent	Function	Start code = 0	
1	0 - 19	0 - 7	<b>Shutter, Strobe, Reset, Lamp On/Off</b> Shutter Closed (lamp reduced to 700 W (E-ballast) after 10 sec.)		
	20 - 49	8 - 19	No function (Shutter Open)		
	50 - 72	20 - 28	Strobe on fast->slow		
	73 - 79	29 - 31	Shutter open, lamp reduced to 700 W (E-ballast)		
	80 - 99	32 - 39	Pulse opening fast ->slow		
	100 - 119	40 - 47	Pulse closing fast ->slow		
	120 - 127	48 - 50	No function		
	128 - 147	51 - 57	Random Strobe Fast		
	148 - 167	58 - 65	Random Strobe Medium		
	168 - 187	66 - 73	Random Strobe Slow		
	188 - 190	74 - 74	No function		
	191 - 193	75	Random pulse opening fast		
	194 - 196	76	Random pulse opening slow		
	197 - 199	77	Random pulse closing fast		
	200 - 202	78 - 79	Random pulse closing slow		
	203 - 207	80 - 81	No function		
	208 - 217	82 - 85	Reset Fixture		
	218 - 227	86 - 89	No function		
	228 - 237	90 - 93	Lamp On (Power On)		
	238 - 247	94 - 97	No Function		
	248 - 255	98 - 100	Lamp Off (Power Off) <b>Note:</b> T > 5 seconds		
	2	0 - 255	0 - 100	<b>Intensity</b> 0 – 100%	
	3	0 - 255	0 - 100	<b>Cyan</b> White -> Cyan	
	4	0 – 255	0 - 100	<b>Magenta</b> White -> Magenta	
5	0 – 255	0 - 100	<b>Yellow</b> White -> Yellow		
6	0 – 255	0 - 100	<b>CTC</b> White -> CTC		
7	0 – 9	0 - 3	<b>Rotating gobo 1 selection</b> Open gobo		
	10 – 14	4 - 5	Gobo 1 – Indexing (set index on channel 8)		
	15 – 19	6 - 7	Gobo 2 – Indexing (set index on channel 8)		
	20 – 24	8 - 9	Gobo 3 – Indexing (set index on channel 8)		
	25 – 29	10 - 11	Gobo 4 – Indexing (set index on channel 8)		
	30 – 34	12 - 13	Gobo 5 – Indexing (set index on channel 8)		
	35 – 39	14 - 15	Gobo 1 – Cont. Rotation (set dir/speed on channel 8)		
	40 – 44	16 - 17	Gobo 2 – Cont. Rotation (set dir/speed on channel 8)		
	45 – 49	18 - 19	Gobo 3 – Cont. Rotation (set dir/speed on channel 8)		
	50 – 54	20 - 21	Gobo 4 – Cont. Rotation (set dir/speed on channel 8)		
	55 – 59	22 - 23	Gobo 5 – Cont. Rotation (set dir/speed on channel 8)		
	60 – 74	24 - 29	<b>Gobo shake (indexing)</b> Gobo 1 slow -> fast		
	75 – 89	30 - 35	Gobo 2 slow -> fast		
	90 – 104	36 - 41	Gobo 3 slow -> fast		
	105 – 119	42 - 46	Gobo 4 slow -> fast		
	120 – 134	47 - 52	Gobo 5 slow -> fast		
	135 – 149	53 - 58	<b>Gobo shake (continuous gobo rotation)</b> Gobo 1 slow -> fast		
	150 – 164	59 - 64	Gobo 2 slow -> fast		
	165 – 179	65 - 70	Gobo 3 slow -> fast		
	180 – 194	71 - 67	Gobo 4 slow -> fast		
	195 – 209	77 - 82	Gobo 5 slow -> fast		
	210 – 232	83 - 91	<b>Gobo wheel continuous rotation (continuous gobo rotation)</b> CW slow -> fast		
	233 – 255	92 - 100	CCW fast -> slow		

DMX channel	Value	Percent	Function	Start code = 0
8	0 – 255	0 - 100	<b>Rotating gobo index</b> (Set gobo selection on channel 7) Index min. -> max	
	0 – 2	0 - 1	<b>Rotating gobo cont. rotation</b> (Set gobo selection on channel 7) Static	
	3 – 127	2 - 50	CCW slow -> fast	
	128 – 252	51 - 98	CW fast -> slow	
	253 – 255	99 - 100	Static	
9	0 – 9	0 - 3	<b>Gobo Animation wheel position</b> No Effect	
	10 – 19	4 - 7	Vertical position – Indexing (set index on channel 10)	
	20 – 29	8 - 11	Horizontal position – Indexing (set index on channel 10)	
	30 – 39	12 - 15	Vertical position – Cont. Rotation (set dir/speed on channel 10)	
	40 – 49	16 - 19	Horizontal position – Cont. Rotation (set dir/speed on channel 10)	
	50 – 139	20 - 54	Animation wheel scroll position (Vertical -> Horizontal) – Indexing (set index on channel 10)	
	140 – 229	55 - 89	Animation wheel scroll position (Horizontal -> Vertical) – Cont. Rot. (set dir/speed on channel 10)	
	230 – 235	90 - 92	No Effect	
			<b>Gobo Animation MACROS</b>	
		236 – 239	93	Macro 1
	240 – 243	94 - 95	Macro 2	
	244 – 247	96	Macro 3	
	248 – 251	97 - 98	Macro 4	
	252 – 255	99 - 100	Macro 5	
10	0 – 255	0 - 100	<b>Gobo Animation wheel index</b> (Set position on channel 9) Index min. -> max	
	0 – 2	0 - 1	<b>Gobo Animation wheel cont. rotation</b> (Set position on channel 9) Static	
	3 – 127	2 - 50	CCW slow -> fast	
	128 – 252	51 - 98	CW fast -> slow	
	253 – 255	99 - 100	Static	
11	0	0	<b>Effect selection</b> Open	
	1 – 234	1 - 91	Variable Frost min. -> max.	
	235 – 242	92 - 94	Effect 1	
	243 – 250	95 - 98	Effect 2	
	251 – 255	99 - 100	Open	
12	0 – 199	0 - 78	<b>Iris</b> Open -> close	
	200 – 215	79 - 84	Close	
	216 – 229	85 - 89	Pulse opening fast -> slow	
	230 – 243	90 - 95	Pulse closing fast -> slow	
	244 – 246	96	Random pulse opening fast	
	247 – 249	97	Random pulse opening slow	
	250 – 252	98	Random pulse closing fast	
	253 – 255	99 - 100	Random pulse closing slow	
13	0 – 2	0 - 1	<b>Framing MACRO functions</b> No Macro	
	3 – 255	2 - 100	Reserved for MACROs	
14	0 – 255	0 - 100	<b>Focus</b> Focus far -> near	
15	0 – 255	0 - 100	<b>Zoom</b> Zoom wide -> narrow	
16	0 – 255	0 - 100	<b>Framing shutter 1</b> Out -> In	
17	0 – 126	0	<b>Framing shutter 1</b> Angle –	
	127-128	50	Parallel	
	129 – 255	100	Angle +	
18	0 – 255	0 - 100	<b>Framing shutter 2</b> Out -> In	
19	0 – 126	0	<b>Framing shutter 2</b> Angle –	
	127-128	50	Parallel	
	129 – 255	100	Angle +	

DMX channel	Value	Percent	Function	Start code = 0
20	0 – 255	0 - 100	<b>Framing shutter 3</b> Out -> In	
21	0 – 126 127-128 129 – 255	0 50 100	<b>Framing shutter 3</b> Angle – Parallel Angle +	
22	0 – 255	0 - 100	<b>Framing shutter 4</b> Out -> In	
23	0 – 126 127-128 129 – 255	0 50 100	<b>Framing shutter 4</b> Angle – Parallel Angle +	
24	0 - 255	0 - 100	<b>Rotate Framing Shutters</b> Right - > Center -> Left	
25	0 127 255	0 50 100	<b>Pan</b> Max Left Neutral Max Right	
26	0 127 255	0 50 100	<b>Tilt</b> Max Up Neutral Max Down	
27	0 - 2 3 – 236 237 – 239 240 – 242 243 – 245 246 – 248 249 – 251 252 – 255	0 - 1 2 - 92 93 94 - 95 96 97 98 99 - 100	<b>Speed: Pan/Tilt Movement</b> Tracking Speed Fast -> Slow Tracking (Slow speed - Overriding the PTSP menu setting) Tracking (Normal speed - Overriding the PTSP menu setting) Tracking (Fast speed - Overriding the PTSP menu setting) Fan speed (Regulation, min. noise level – Overriding the FAN menu setting) Fan speed (Full speed, max. cooling – Overriding the FAN menu setting) Blackout while moving	
28	0 – 2 3 – 239 240 – 242 243 – 245 246 – 248 249 – 251 252 – 255	0 - 1 2 - 93 94 - 95 96 97 98 99 - 100	<b>Speed: Dimmer, Cyan, Magenta, Yellow, CTC, Effect, Iris, Focus, Zoom</b> Tracking Speed Fast -> Slow Tracking (Studio mode disabled – Overriding the MOfE menu setting) Tracking (Studio mode enabled – Overriding the MOfE menu setting) Tracking (Shortcuts disabled - Overriding the SCUT menu setting) Tracking (Shortcuts enabled - Overriding the SCUT menu setting) Fast Speed  <b>Speed: Gobo 1, Framing, Animation wheel pos., Animation wheel rot.</b> Tracking Speed Fast -> Slow Tracking (Studio mode disabled – Overriding the MOfE menu setting) Tracking (Studio mode enabled – Overriding the MOfE menu setting) Tracking (Shortcuts disabled - Overriding the SCUT menu setting) Tracking (Shortcuts enabled - Overriding the SCUT menu setting) Blackout while moving	

# CONTROL MENU

Menu	Item	Options	Notes (Default settings in bold print)	
Addr	-	1 - 512	DMX address.	
PSET	-	8bit	Full control with coarse pan, tilt, and gobo indexing.	
		<b>16bit</b>	Full control with fine pan, tilt, and gobo indexing.	
PATI	SWAP	ON	Map DMX pan control to tilt channel and vice versa.	
		<b>OFF</b>	Normal pan and tilt control.	
	PINV	ON	Reverse DMX pan control, right → left.	
		<b>OFF</b>	Normal pan control, left → right.	
	TINV	ON	Reverse DMX tilt control, down → up.	
		<b>OFF</b>	Normal tilt control, up → down.	
PTSP	-	<b>NORM</b>	Medium pan/tilt speed.	
		FAST	Optimize movement for speed.	
		SLOW	Optimize movement for smoothness.	
Stud	-	<b>OFF</b>	Optimize effects for speed.	
		ON	Optimize effects for silence.	
PERS	dISP	<b>ON</b>	Display remains on.	
		OFF	Display extinguishes 2 minutes after last key press.	
	dINT	10 - 100	Adjust display intensity.	
	dLOF	ON	Enable DMX lamp off command.	
		<b>OFF</b>	Disable DMX lamp off command.	
	dRES	<b>ON</b>	Enable DMX reset command.	
		OFF	Disable DMX reset command.	
	ALON	<b>OFF</b>	No automatic lamp strike.	
		ON	Lamp strikes automatically within 90 seconds of power on.	
		dMX	Lamp strikes if DMX is present, douses 15 mins. after it's missing.	
	SCUT	<b>ON</b>	Gobo and effect wheels turn shortest distance.	
		OFF	Gobo and effect wheel paths oscillate.	
	dICU	dIM1	Smoother dimming during final 25 percent of fade out.	
		dIM2	More responsive but less smooth	
	TRAC	MOdE	<b>MOd1</b> : Absolute delta value algorithm (for most controllers) moD2: Real delta value algorithm.	
		CAL	1 - 10 . Tracking samples. Increase if pan/tilt is not smooth. (Default = 6).	
	dFSE	FACT	LOAD	Return all personality settings (not calibrations) to factory defaults.
		CUS1 , CUS2 , CUS3	LOAD	Load custom configuration.
			SAVE	Save current configuration.

Table 2: Control menu

Menu	Item	Options	Notes (Default settings in bold print)
INFO	TIME / HRS	TOTL	Total hours of operation since fabricated.
		RSET	Hours of operation since counter reset. To reset, display counter and press [↑] for 5 seconds.
	TIME / L HR	TOTL	Total hours of operation with lamp on since fabricated.
		RSET	Lamp hours since counter reset. To reset, display counter and press [↑] for 5 seconds.
	TIME / L ST	TOTL	Total number of lamp strikes since fabricated.
		RSET	Number of lamp strikes since counter reset. To reset, display counter and press [↑] for 5 seconds.
	TEMP	HEAd	Head temperature.
		bASE	Base temperature.
		LAMP	Temperature in the lamp module (not the temperature of the lamp itself).
	VER	-	CPU firmware version.
dMXL	-	STCO	Decimal value of the DMX start code. The start code must be 0 for the MAC 2000 Performance II to function properly.
		dIM . . EFSP	DMX value (from 0 - 255) received for each channel.
MAN	RST	-	Reset fixture.
	L ON	-	Lamp on.
	L OFF	-	Lamp off.
	SHUT	OPEN	Open shutter.
		CLOS	Close shutter.
		STRF	Fast strobe.
		STRM	Medium strobe.
		STRS	Slow strobe.
	dIM	0 - 255	Dimmer.
	CYAN, MAG, YEL	0 - 255	White →Cyan/Magenta/Yellow.
	CTC	0 - 255	Color temperature correction. Cold →Warm (0-178 mireds).
	GOB	OPEN	Gobo wheel. Open position.
		g1 I - g5 I	Gobo wheel. Indexed gobos 1→5.
		g1 g - g5 R	Gobo wheel. Rotating gobos 1→5.
		g1 IS - g5 IS	Gobo wheel. Indexed gobo shake 1→5.
		g1 RS - g5 RS	Gobo wheel Rotating gobo shake 1→5.
		CW F	Gobo wheel. Clockwise wheel rotation - fast.
		CCWF	Gobo wheel. Counter clockwise wheel rotation - fast.
		CW M	Gobo wheel. Clockwise wheel rotation - medium.
		CCWM	Gobo wheel. Counter clockwise wheel rotation - medium.
CW S		Gobo wheel. Clockwise wheel rotation - slow.	
CCWS		Gobo wheel. Counter clockwise wheel rotation - slow.	
I / S	0 - 255	Clockwise rotation of gobo. Slow→fast.	

Table 2: Control menu

Menu	Item	Options	Notes (Default settings in bold print)
MAN cont.	ANIW	AWAY	Gobo animation wheel. Move away from optical path.
		VL 0 - 9	Gobo animation wheel. Select speed of vertical movement left.
		VR 9 - 0	Gobo animation wheel. Select speed of vertical movement right.
		HR 0 - 9	Gobo animation wheel. Select speed of horizontal movement right.
		HL 9 - 0	Gobo animation wheel. Select speed of horizontal movement left.
	EFF	F 0 - F175	Effects. Variable frost 0→100%.
		EFF1	Effect 1.
		EFF2	Effect 2.
	IRIS	I 0 - I199	Iris - Open→Closed.
		POUT	Pulse opening.
		P IN	Pulse closing.
		RNdO	Random pulse opening.
		RNdI	Random pulse closing.
	FOC	0 - 255	Focus - Infinity→Near.
	ZOOM	0 - 255	Zoom - Flood→spot.
	b1IO	0 - 255	Framing shutter blade 1. Move in or out.
	b1AG	R000 - R127	Framing shutter blade 1. Angle right 0 - 127.
		L000 - L127	Framing shutter blade 1. Angle left 0 - 127.
	b2IO	0 - 255	Framing shutter blade 2. Move in or out.
	b2AG	R000 - R127	Framing shutter blade 2. Angle right 0 - 127.
		L000 - L127	Framing shutter blade 2. Angle left 0 - 127.
	b3IO	0 - 255	Framing shutter blade 3. Move in or out.
	b3AG	R000 - R127	Framing shutter blade 3. Angle right 0 - 127.
		L000 - L127	Framing shutter blade 3. Angle left 0 - 127.
	b4IO	0 - 255	Framing shutter blade 4. Move in or out.
	b4AG	R000 - R127	Framing shutter blade 4. Angle right 0 - 127.
		L000 - L127	Framing shutter blade 4. Angle left 0 - 127.
PAN	0 - 255	Pan - Left→Right	
TILT	0 - 255	Tilt - Up→Down	
TSEQ	-	RUN	Run a general test of all effects

Table 2: Control menu

Menu	Item	Options	Notes (Default settings in bold print)
UTIL (Press and hold Enter for a few seconds to use this menu)	FEbA	<b>ON</b>	Enable pan/tilt position correction system.
		OFF	Disable pan/tilt feedback. Setting not saved.
	EFFb	<b>ON</b>	Enable on the fly reset of color, gobo, and effect wheels.
		OFF	Disable on the fly reset of color, gobo, and effect wheels.
	Adj	-	See "Adjustment submenu" on page 49.
	CAL/P OF	1 - 255	Pan offset.
	CAL/T OF	1 - 255	Tilt offset.
	CAL/d OF	1 - 255	Dimmer offset.
	CAL/C OF	1 - 255	Cyan offset.
	CAL/M OF	1 - 255	Magenta offset.
	CAL/Y OF	1 - 255	Yellow offset.
	CAL/CTOF	1 - 255	CTC offset.
	CAL/GOBO	1 - 255	Gobo wheel offset.
	CAL/EFOF	1 - 255	Effect wheel offset.
	CAL/IROF	1 - 255	Iris offset.
	CAL/FOOF	1 - 255	Focus offset.
	CAL/ZOOF	1 - 255	Zoom offset.
	dFOF	SURE	Return all offsets to the default settings.
	PCbT	LEd	PCB test for service use only.
	FANS	REG	Regulate the effect cooling fans for quieter performance. Enabling this option increases the operating temperature and thus increases wear on the components.
<b>FULL</b>		Operate cooling fans at full speed. This is the default from software version 1.4.	
UPLd	SURE	Manually set fixture to software update mode.	
MSG (when Service LED is lit)	Replace lamp		Displayed when lamp hours exceed average life (750 hours).
	Fixture overheating		Displayed if head temperature exceeds 120° C (248° F).

Table 2: Control menu



# ADJUSTMENT SUBMENU

This functions are used by Martin service technicians to adjust the fixture. This menu is located under UTIL / Adj.

Menu	Item	Options	Notes
RST	-	-	Reset fixture.
L ON	-	-	Strike lamp.
LoFF	-	-	Douse lamp.
HEAD	dIM	OPEN	Open dimmer.
		Adj	Turn dimmer to adjustment position (closed mechanical stop).
		CLOS	Close dimmer.
		STRO	Strobe.
	CYAN, MAG, YEL, CTC	MIN	Color flags out.
		MAX	Color flags in.
	GObo	TOOL	For gobo adjustment at factory.
		OPEN	Turn gobo wheel to open position.
		Adj	Turn gobo wheel to adjustment position.
	ANIW	SW P	Animation wheel switch position adjustment.
		OUT	Animation wheel out position adjustment.
		VER	Animation wheel vertical position adjustment.
		HOR	Animation wheel horizontal position adjustment.
	EFF	TOOL	For effect wheel adjustment at factory.
		OPEN	Turn effect wheel to open position.
		Adj	Turn effect wheel to adjustment position.
	IRIS	OUT	Iris out.
		IN	Iris in.
	bEAM	Adj	Beam adjustment.
		IN	Beam in.
		OUT	Beam out.
	FROT	LEFT	Frame rotation left.
		RIGH	Frame rotation right.
	FOCU	NEAR	Move focus lens to front.
		FAR	Move focus lens to back.
	ZOOM	NARR	Zoom to full spot.
		WIDE	Zoom to full flood.

**Table 3: Adjustment menu**

Menu	Item	Options	Notes
P A T I	-	NEUT	Move pan and tilt to neutral positions.
		PNTd	Pan neutral, tilt down.
		PNTU	Pan neutral, tilt up.
		PLTN	Pan left, tilt neutral.
		PRTN	Pan right, tilt neutral.
		PLTd	Pan left, tilt down.
		PRTU	Pan right, tilt up.

**Table 3: Adjustment menu**

# DISPLAY MESSAGES

Message	Appears when...	What to do
RST ( Reset)	... the fixture is indexing effects at startup.	Wait for reset to complete.
SRST (Serial reset)	... the fixture has received a reset command from the controller.	Wait for reset to complete. Set PERS/dRES to off to prevent accidental reset commands.
HOME	... the effects have been indexed and are moving to their default positions.	Wait a few moments.
OPEN	...the lamp access cover is not fully closed.	Verify that the lamp access cover is locked in place.
LERR (Lamp error)	... the lamp doesn't ignite within 10 minutes of receiving the 'Lamp ON' command. Likely reasons are a missing or defective lamp, or insufficient AC voltage.	Check the lamp. Check that the voltage and frequency settings match the local supply.
MERR (Memory error)	...the EEPROM memory cannot be read.	Contact Martin service personnel for assistance.
ShER (Short error)	... the fixture detects the lamp is ON but no 'Lamp ON' command has been received. This can occur if the lamp relay is stuck or if the lamp-power feedback circuit fails. The fixture may be operated but remote lamp on/off may be affected.	Contact Martin service personnel for assistance.
bTER (Base temperature error) HTER (Head temperature error)	... there is a fault with the temperature sensor in the base or head.	Contact Martin service personnel for assistance.
FbEP (Feedback error pan) FbET (Feedback error tilt) FbER (Feedback error pan/tilt)	...pan (FbEp), tilt (FbET) or both (FbER) feedback circuits are malfunctioning. It will still be possible to operate the fixture, though it goes into a "safe" mode where maximum speed is reduced, thus preventing the fixture from losing track of its home position (losing step).	Contact Martin service personnel for assistance.
PAER (Pan time-out) TIER (Tilt time-out) CYER (Cyan time-out) MAER (Magenta time-out) YEER (Yellow time-out) CTER (CTC time-out) FOER (Focus time-out) ZOER (Zoom time-out)	...the electric indexing circuit is malfunctioning. The fixture will, after the time-out, establish a mechanical stop, and continue to work normally.	Reset fixture again. Contact Martin service personnel if problem continues.
gOER (Gobo wheel time-out) gRER (Gobo wheel rotation time-out) aPER (Animation wheel position time-out) aRER (Animation wheel rotation time-out) EFER (Effect wheel time-out) RFER (Frame rotation index time-out)	...the magnetic-indexing circuit malfunctions (e.g. sensor defective or magnet missing). After the time-out, the effect in question stops in a random position.	Reset fixture again. Contact Martin service personnel if problem continues.
S3SC S4SC S5SC S6SC S7SC S8SC S9SC S10S S11S S12S	...an effect does not move away from the index position under reset, a sensor or micro-switch circuit is shorted, or a micro-switch is stuck or connected incorrectly.	Contact Martin service personnel for assistance.
RAME	...there is an on board RAM memory error.	Contact Martin service personnel for assistance.
OPER	...there is an on-board programming error.	Contact Martin service personnel for assistance.

Table 4: Display messages

<b>Message</b>	<b>Appears when...</b>	<b>What to do</b>
L1ER	...light sensor 1 is in error status.	Contact Martin service personnel for assistance.
THER	---there is a thermoswitch error or a jumper on PL47 error.	Contact Martin service personnel for assistance.

**Table 4: Display messages**

# TROUBLESHOOTING

<b>Problem</b>	<b>Probable cause(s)</b>	<b>Remedy</b>
One or more of the fixtures is completely dead.	No power to fixture.	Check that power is switched on and cables are plugged in.
	Primary fuse blown (located near mains inlet).	Disconnect fixture and replace fuse.
	Secondary fuse(s) blown (located on PCB inside base).	Disconnect fixture. Check fuses on PCB and replace.
Fixtures reset correctly but respond erratically or not at all to the controller.	Bad data link.	Inspect connections and cables. Correct poor connections. Repair or replace damaged cables.
	Data link not terminated.	Insert termination plug in output jack of the last fixture on the link.
	Incorrect addressing of the fixtures.	Check fixture address and protocol settings.
	One of the fixtures is defective and disturbs data transmission on the link.	Bypass one fixture at a time until normal operation is regained: unplug the XLR in and out connectors and connect them directly together. Have the fixture serviced by a qualified technician.
	XLR pin-out on fixtures does not match (pins 2 and 3 reversed).	Install a phase-reversing cable between the fixtures or swap pins 2 and 3 in the fixture that behaves erratically.
Magnetically indexed effect resets correctly but wanders after fixture reaches operating temperature.	Effect wheel requires mechanical adjustment.	Disable effects feedback (page 16). Contact Martin technician for service.
Mechanical effect loses position.	Mechanical train requires cleaning, adjustment, or lubrication.	Contact Martin technician for service.
No light and "LERR" error message displayed.	Lamp blown	Disconnect fixture and replace lamp.
	Lamp not installed	Disconnect fixture and install lamp.
	Lamp access safety switch open	Verify that lamp access plate is fully seated and locked in place.
Lamp cuts out intermittently.	Fixture is too hot.	Allow fixture to cool. Clean air filters. Reduce ambient room temperature.

**Table 5: Troubleshooting**

# CIRCUIT BOARD CONNECTIONS

	Performance
1	Gobo
2	Gobo rot.
3	LA
4	LB
5	TA
6	TB
7	RA
8	RB
9	BA
10	BB
11	Frame rot.
12	A.W. position
13	A.W. rot.
14	Focus
15	Zoom
16	Dimmer
17	CTC
18	Yellow
19	Magenta
20	Cyan
21	Effect wheel
22	Iris
23	Door switch
24	Tilt feedback
25	Pan feedback
26/27	AW / frame switch
28/29	Gobo sensor
30	P/ T switch
31	Effect sensor
31	
31	
32	Tilt
33	Pan
34	CMY switch
35	
35/36	
41	Light sensor
42	Lamp hous. temp
F1	Head left fan
F2	Head right fan
F3	Head top fan
F4	Head bottom fan
F5	Base power fan
F6	Base dis. side fan
F7	E. ballast fan

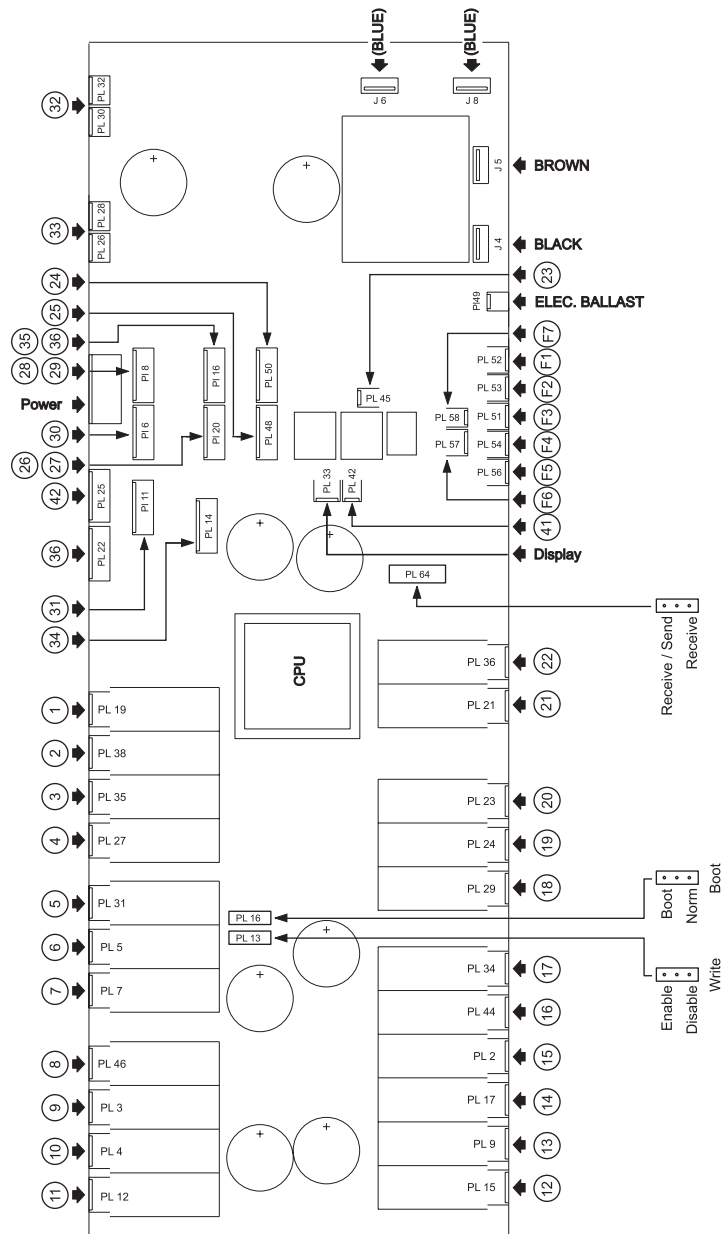

# SPECIFICATIONS

## MAC 2000 PERFORMANCE II

### PHYSICAL

Length:	408 mm (16.0 in)
Width:	490 mm (19.3 in)
Height:	743 mm (29.3 in)
Weight:	39.5 kg (87 lbs)

### SOURCE

Lamp:	1200 W short arc discharge
Base:	Double-ended SFc 10-4 with key
Approved models:	Philips MSR 1200 SA/DE Gold (installed), Osram HMI 1200 W/S Short-Arc
Control:	automatic and remote, hot re-strike
Ballast:	electronic
Low voltage power supply:	electronic auto-ranging, or manually set

### THERMAL

Maximum ambient temperature (Ta):	40° C (104° F)
Maximum surface temperature:	140° C (284° F)
Total heat dissipation:	ca. 5120 Btu/hr

### PHOTOMETRICS

Light output:	23000 lumens
Beam angle (focused on open gobo):	12° - 29°
Focal length:	.58 - 143 mm
Measurement source:	Osram HMI 1200 W/S

### ELECTRICAL

AC input:	3 m trailing cable w/o cord cap
Operating ranges:	100-130/200-260 V, 50/60 Hz
Ballast:	electronic
Power supply:	auto-ranging
Main fuses (x 2 - when local AC supply is 208 - 250 V):	15 A
Main fuses (x 2 - when local AC supply is 100 - 120 V):	T 20 A
Fuse F101:	T 6.3 A
Fuse F102:	T 10 A
Fuse F103:	T 3.15 A
Fuse F104:	T 3.15 A

### MAXIMUM POWER AND CURRENT

100 V / 50 Hz:	1590 W, 19.8 A
100 V / 60 Hz:	1560 W, 19.3 A
120 V / 50 Hz:	1560 W, 16.8 A
120 V / 60 Hz:	1540 W, 16.3 A
208 V / 50 Hz:	1470 W, 10.5 A
208 V / 60 Hz:	1470 W, 10.3 A
230 V / 50 Hz:	1480 W, 9.6 A
230 V / 60 Hz:	1470 W, 9.4 A
250 V / 50 Hz:	1480 W, 8.6 A
250 V / 60 Hz:	1480 W, 8.5 A

### GOBOS

Outside diameter:	37.5 +0/-0.3 mm (1.48 +0/-0.01 in.)
Image diameter:	30 mm (1.18 in.)
Thickness:	1.1 mm in static slots, up to 7 mm in rotating slots
Material:	high-temperature Borofloat or better glass
Coating:	dichroic or enhanced aluminum

## GOBO ANIMATION WHEELS

Outside diameter:	.133 mm +0/-0.25 mm
Image outer diameter:	130 mm (5.12 in)
Image inner diameter:	16 mm (0.63 in)
Thickness:	0.5 mm (0.02 in)
Construction:	Aluminium

## CONTROL AND PROGRAMMING

Protocol:	USITT DMX-512
Control channels:	28 or 31
Receiver:	Opto-isolated RS-485
Data I/O:	locking 3-pin & 5-pin XLR, pin 1 shield, pin 2 cold (-), pin 3 hot (+)
Setting and addressing:	LED control panel, remote w/ MP-2 uploader
Pan/tilt resolution:	8- or 16-bit
Gobo indexing:	8- or 16-bit
Movement control:	tracking and vector
Software installation:	serial upload (MUF)

## ELECTROMECHANICAL EFFECTS

Cyan:	0 - 100%
Magenta:	0 - 100%
Yellow:	0 - 100%
Color correction:	0 - 178 mireds
Gobo animation wheel:	Animation effects at any angle
Gobo wheel:	5 rotating and indexable slots
Four-blade framing system:	Blade tilting +/- 31°, frame rotation +/- 45°
Effect wheel:	wide-angle converter lens, non-rotating 9-facet prism, variable frost
Iris:	motorized
Dimmer/shutter:	full range dimming and variable speed flash
Focus:	.2 m (6.5 ft.) - infinity
Zoom:	10° - 28°
Pan:	540°
Tilt:	267°

## DESIGN STANDARDS

EU EMC:	EN 50 081-1, EN 50 082-1
EU safety:	EN 60598-1, EN 60598-2-17
Canadian safety:	CSA C22.2 No. 166
US safety:	ANSI/UL 1573

## CONSTRUCTION

Housing:	UV-resistant fiber-reinforced composite
Colors:	black
Protection factor:	IP 20

## INSTALLATION

Mounting points:	8 pairs of 1/4-turn locks, offset 45°
Orientation:	any

## ORDERING INFORMATION

MAC 2000 Performance II in a 1-unit flight case:	P/N 90205460
2 MAC 2000 Performance IIs in a 2-unit flight case:	P/N 90205450

## INCLUDED ITEMS

2 x Omega bracket, 1/4-turn	
User manual:	P/N 35000103
Realistic stars gobo (E size):	P/N 43036008
Cloud gobo (E size):	P/N 43036008
Radial breakup gobo animation wheel (installed):	P/N 62400211
Cloud breakup animation wheel:	P/N 62400213
Dot breakup animation wheel:	P/N 62400214
Tangential breakup animation wheel:	P/N 62400215
Spiral breakup animation wheel:	P/N 62400216



**ACCESSORIES**

Linear breakup gobo animation wheel . . . . .	P/N 62400223
Triangle break gobo animation wheel . . . . .	P/N 62400225
Elliptical breakup gobo animation wheel . . . . .	P/N 62400221
Flicker wheel gobo animation wheel . . . . .	P/N 62400222
Coarse radial breakup gobo animation wheel . . . . .	P/N 62400224
Coarse tangential breakup gobo animation wheel . . . . .	P/N 62400226
MP-2 Uploader: . . . . .	P/N 90758420
G-clamp: . . . . .	P/N 91602003
Half-coupler clamp . . . . .	P/N 91602005
“The Wife” DMX Tester . . . . .	P/N 91611038
Philips MSR 1200 SA/DE Gold lamp . . . . .	P/N 97010310
OSRAM HMI 1200 W/S lamp . . . . .	P/N 97010304