

150W Single Base

user manual



Alien 02 Series

Measurements are in millimeters

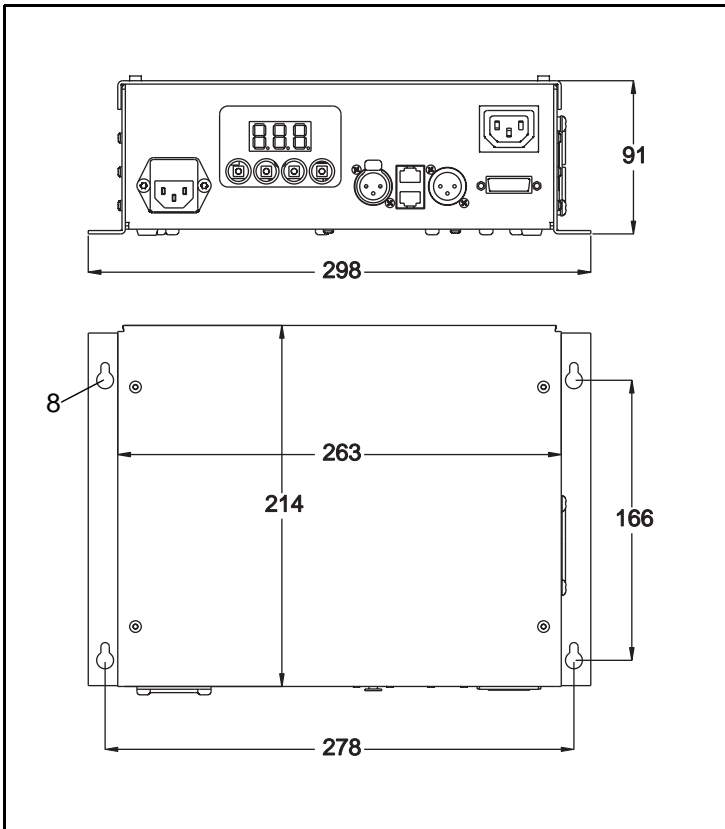

© 2002 Martin Professional A/S, Denmark.

All rights reserved. No part of this manual may be reproduced, in any form or by any means, without permission in writing from Martin Professional A/S, Denmark.

Printed in Denmark.

P/N 35000110, Rev C

SECTION 1. GETTING STARTED

INTRODUCTION	6
Safety information	6
Task checklist	8
INSTALLATION	9
Unpacking	9
Fixture orientation and location	9
AC power	10
Connecting the Alien 02 luminaire	12
Data linking multiple fixtures	13
GENERAL OPERATION	15
External control	15
Stand-Alone programming	15
Control panel	16
Menus	16

SECTION 2. STAND-ALONE OPERATION

STAND-ALONE PROGRAMMING OVERVIEW	22
About scene timing	22
Synchronizing scene changes for multiple 150W Single Bases	23
Programming methods	24
PROGRAMMING USING THE FIXTURE CONTROL PANEL	25
Before you begin programming	25
Stand alone programming menu (SA/Prg)	26
PROGRAMMING USING THE OPTIONAL INFRARED REMOTE CONTROL	28
Before you begin programming	28
Remote control commands	30
STAND-ALONE SHOW PLAYBACK	32
Starting show playback	32
Show Execution with the IR remote control	32
Scene execution Using the optional MC-X.	33
DMX controller override during Stand-Alone show playback	33
RULES FOR SYNCHRONOUS TRIGGERING DURING STAND-ALONE OPERATION	34

SECTION 3. DMX CONTROL

DMX CONTROLLER OPERATION	38
Connecting a DMX control device	38

Control address selection	38
Disable Stand-Alone operation (if required)	39
Lamp control	39
Effects	40
DMX PROTOCOL42
 SECTION 4. SERVICE AND TROUBLESHOOTING	
SERVICE44
Cleaning	44
Firmware updates	44
Fuse replacement	46
TROUBLESHOOTING47
Error messages	48
PRINTED CIRCUIT BOARD LAYOUT49
 SECTION 5. REFERENCE	
CONTROL MENU STRUCTURE52
SPECIFICATIONS57

SECTION 1. GETTING STARTED

INTRODUCTION

Thank you for selecting the Martin 150W Single Base. The 150W Single Base controls a single Alien 02 150-watt color-changing medium-throw luminaire designed for fixed interior installation. It features seamless CMY color mixing and full-range continuous dimming. The 150W Single Base may be operated with DMX control devices.

The 150W Single Base is the controlling unit for all the 150 watt luminaire models in the Alien 02 range.

The Alien 02 product range is made up of a number of luminaires and accessories:

- Alien 02 Spot - a pedestal or arm mounted luminaire
- Alien 02 Pendant - a ceiling hung luminaire
- 150W Single Base - provides power and intelligent control functions to a single Alien 02 luminaire
- Mounting arms of varying lengths for the Alien 02 Spot
- Cable extension kit for extending the distance between the 150W Single Base and an Alien 02 luminaire
- 36° fresnel lens kit
- 90° x 70° beam shaper lens kit
- Micro lens diffuser kit
- Barn doors

Note: *It is important to read this manual through and to understand the configuration and control options that are available before you attempt to install this product.*

SAFETY INFORMATION

Warning! *This product is for professional use only. It is not for household use.*

These products present risks of lethal or severe injury due to fire and heat, electric shock and falls. **Read this manual** before powering or installing these fixtures, follow the safety precautions listed below and observe all warnings in this manual and on the fixtures. If you have questions about

how to operate these fixtures safely, please contact your Martin dealer or call the Martin 24-hour service hotline at +45 70 200 201.

Protection from electric shock

- Disconnect the fixtures from AC power before removing or installing a lamp, fuses, or any part, and when not in use.
- Always ground (earth) the fixtures electrically.
- Use only a source of AC power that complies with local building and electrical codes and has both overload and ground-fault protection.
- Do not expose the fixtures to rain or moisture.
- Refer all service to a Martin service technician.

Protection from burns and fire

- Never attempt to bypass the thermostatic switch or fuses. Always replace defective fuses with ones of the specified type and rating.
- Provide a minimum clearance of 0.1 meters (4 inches) around fans and air vents.
- Never place filters or other materials over the lens.
- Do not modify the fixture or install other than genuine Martin parts.
- Do not operate the fixture if the ambient temperature (T_a) exceeds 40° C (104° F).

Protection from injury due to falls

- Verify that all external covers and rigging hardware are securely fastened
- Block access below the work area whenever installing or removing the fixture.

TASK CHECKLIST

√	Task	See
	Unpack and check all parts are included	page 9
	Choose a location and screw/bolt 150W Single Base in place	page 9
	Set voltage	page 10
	Install the mains fuse	page 11
	Install power cord cap/plug	page 11
	Connect fixture to power	page 11
	Create data link if using multiple fixtures	page 13
	Install Alien 02 luminaire	<i>Alien 02 user manual</i>
	Connect Alien 02 luminaire to 150W Single Base	page 12
	Set 150W Single Base personalities using the control menus	page 16
When DMX control device is used		
	Connect DMX control device (if used)	page 38
	Using the control menus, set 150W Single Base profile option to “d1” and set the DMX address	page 16 and page 38
	Program show, or use live control, with DMX control device	page 39
When stand-alone program is used		
	If optional IR is used:	
	<ul style="list-style-type: none"> • Ensure data link not terminated 	page 28
	<ul style="list-style-type: none"> • If this is the first fixture in the data link, install the optional IR receiver 	page 29
	<ul style="list-style-type: none"> • Set fixture IR address 	page 16
	If synchronous triggering of multiple fixtures is to be used, set triggering options (is the fixture receiving or sending scene change triggers?)	page 23
	Create stand-alone program, using:	
	<ul style="list-style-type: none"> • Fixture control menus, or the 	page 25
	<ul style="list-style-type: none"> • Optional IR remote control 	page 28
	Run stand alone program	page 32

INSTALLATION

This section describes in general terms how to mount the fixture and connect it to data and AC power. These procedures shall be performed by qualified professionals.

UNPACKING

The 150W Single Base comes with the following items:

- User manual
- Fuses
- 3 meter (9.8 ft), 3-pin IEC mains cable
- 5 meter (16.4 ft), black, 3-pin XLR data cable

FIXTURE ORIENTATION AND LOCATION

The 150W Single Base is normally connected to an Alien 02 luminaire by the Alien 02s built-in cables. Cable extension kits are available if the 150W Single Base needs to be positioned up to 16 meters (52 feet) away.

The 150W Single Base can be screwed or bolted fast to a surface (including normally flammable surfaces) using 8 mm (1/3 in.) hardware.

The 150W Single Base can be hidden from view in a ceiling space, but keep in mind that access to the fixture may be necessary from time-to-time, for example, if a fuse blows, or when stand-alone programming is to be performed.

If you plan to use the IR Remote Control unit to program the 150W Single Base then the fixture, or at least the IR Receiver unit, will need to be placed where it can be seen by the IR Remote Control unit. Programming with the IR remote control unit is easiest when the user can see the control panel display on the 150W Single Base.

AC POWER

The 150W Single Base has switch-selectable settings to configure the power supply for local conditions. The factory-default setting is indicated on the serial number label. Always use the setting that is closest to the local AC supply.

Warning *For protection from electric shock, the fixture must be grounded (earthed). The power supply shall have overload and ground-fault protection.*

Verify that power supply settings match local AC supply and install the appropriate fuse before applying power.

Changing the voltage setting

The 150W Single Base has switch-selectable settings to configure the power supply for local conditions. The factory-default setting is indicated on the serial number label. Always use the setting that is closest to the local AC supply.

- 1 Disconnect the 150W Single Base from power (A).
- 2 Remove the four cover bolts on the top of the 150W Single Base with a 2.5 mm Allen wrench.
- 3 Set the 5-position switch (B) to the setting closest to the AC voltage. Use the higher setting if the voltage is halfway between 2 settings. For example, use the 230 V setting instead of the 210 V setting for operation with 220 V power.
- 4 Set the 2-position switch (C) to the AC frequency (50 / 60 Hz).
- 5 Replace the cover and apply a new power setting label to the serial number label.

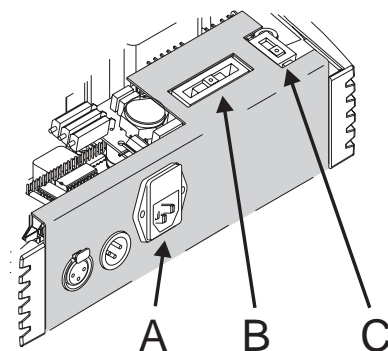
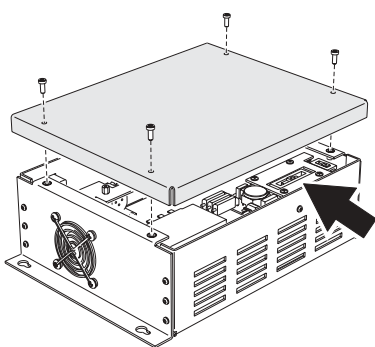

Installing the main fuse

Fuses are provided for 100 - 130 V and 200 - 250 V operation. *Use only the fuse specified for the operating voltage.*

- 1 Locate the bag containing the fuse for your AC voltage.
- 2 Open the fuse holder just about the **MAINS INPUT** socket (A) using a small flat-head screwdriver to open it. The holder may be packed with the other fuse.
- 3 Insert the correct fuse and place the holder back in the **MAINS INPUT** socket.

Installing a plug on the power cable

The power cable to the 150W Single Base must be fitted with a grounding-type cord cap that fits your power distribution system. Consult an electrician if you have any doubts about proper installation.

Following the cord cap manufacturer's instructions, connect the yellow and green wire to ground (earth), the brown wire to live, and the blue wire to neutral. The table below shows some pin identification schemes.

Wire (EU)	Wire (US)	Pin	Marking	Screw (US)
brown	black	live	"L"	yellow or brass
blue	white	neutral	"N"	silver
yellow/green	green	ground		green

Table 1: Cord Cap Connections

Applying power

Connect the mains power cable to the 150W Single Base **MAINS INPUT** socket and the AC mains distribution system. Do not connect the fixture to a dimmer system.

Warning! *The power cables must be undamaged and rated for the electrical requirements of all connected devices.*

Important! *Do not powering through a dimmer system as this can damage the fixture.*

CONNECTING THE ALIEN 02 LUMINAIRE

Connect the built in power-cable on the Alien 02 luminaire to the **DISCHARGE LAMP OUTPUT** socket on the 150W Single Base.

Connect the 26-pin plug on the cable attached to the Alien 02 luminaire to the **DATA OUT** socket on the 150W Single Base. Screw the connector into place.

Warning *Do not connect the Alien 02 luminaire directly to mains power supply - doing so will result in damage to the lamp and the local power supply.*

The Alien 02 luminaire receives its power from the 150W Single Base and must be connected to the DISCHARGE LAMP OUTPUT socket using the attached one-meter long power cable, or a Cable Extension Kit.

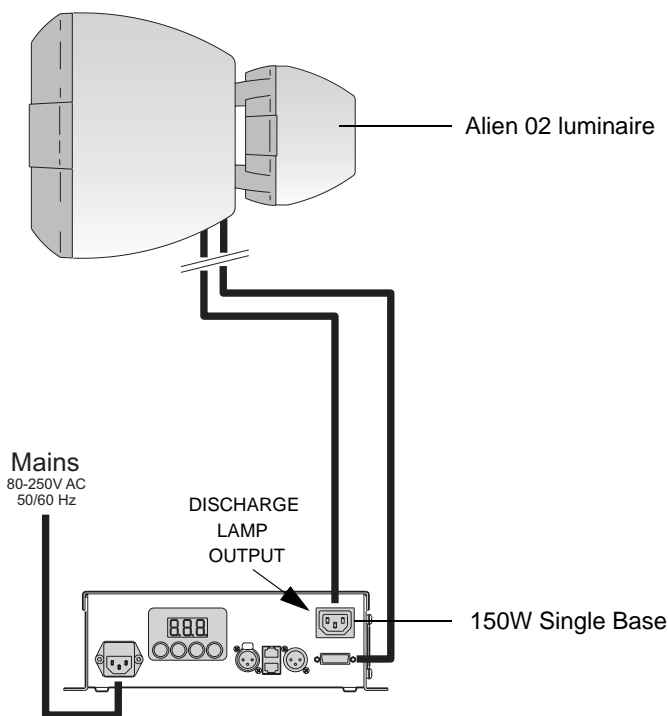

Cable extension kits

Cable extension kits are available that allow the distance between an Alien 02 luminaire and an 150W Single Base to be extended up to a maximum of 16 meters. The kits contain a power cable extension and a data cable

extension. Kits are available in 2, 5, and 10 metre (6.5, 16, and 33 feet) extension lengths.

DATA LINKING MULTIPLE FIXTURES

You need to create a data link if you are going to be:

- Operating multiple 150W Single Bases in a synchronous way
- Controlling more than one fixture via a DMX control device
- Programming multiple fixtures via the IR receiver and IR remote control.

In these cases you need to establish a data link between the devices so that they can communicate. With the 150W Single Base this can be with cables using RJ-45 or XLR connectors (or a mix of both as long as there is not more than one DMX connection in and one DMX connection out on any single fixture).

Creating a data link

Reliable data communication begins with the right cable. Most microphone cable does not transmit digital data reliably over long runs. For best results, use shielded, twisted-pair cable designed for RS-485 applications with low capacitance and a characteristic impedance of 85 to 150 ohms. The minimum wire size is 0.2 mm (24 AWG) for runs up to 300 meters (1000 ft.) and 0.322 mm (26 AWG) for runs up 500 meters (1640 ft.). Your Martin dealer can supply the right cable in various lengths.

The:

- XLR data sockets are wired pin 1 to ground, pin 2 to signal - (cold), and pin 3 to signal + (hot). This is the standard pin assignment for DMX devices.
- RJ-45 sockets are wired pins 7 & 8 to ground, pin 2 to signal - (cold), and pin 1 to signal + (hot). The diagram identifies pins 1 and 8.

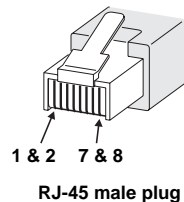
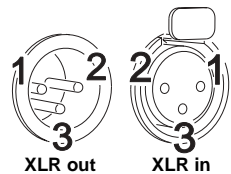

One or more adaptor cables may be required to connect the 150W Single Base to the controller and other lights if they have XLR 5-pin connectors or reversed signal polarity on XLR pins 2 and 3.



5-pin to 3-pin Adaptor	
Male	Female
1	1
2	2
3	3
4	
5	
P/N 11820005	

3-pin to 5-pin Adaptor	
Male	Female
1	1
2	2
3	3
	4
	5
P/N 11820004	

3-pin to 3-pin Phase-Reversing Adaptor	
Male	Female
1	1
2	3
3	2
P/N 11820006	

CREATING THE DATA LINK

- 1 Connect one of the DMX outputs of the 150W Single Base to one of the DMX inputs of the next fixture. If connecting to a fixture with XLR reversed-polarity (pin 3 cold), insert a phase-reversing cable between the two fixtures.
- 2 Continue connecting fixtures output to input. Up to 32 devices may be connected on a serial link, unless you are using the optional infrared remote control and receiver (see “Programming using the optional infrared remote control” on page 28), in which case the limit is 10 fixtures.

Male Termination Plug
Male XLR
1
2  120
3  120
P/N 91613017

- 3 If you are not using the infrared remote control and receiver, terminate the link by inserting a male termination plug (P/N 91613017) into the DMX data output of the last fixture. An XLR termination plug is simply a connector with a 120 ohm, 0.25 W resistor soldered across pins 2 and 3. You can also use an RJ-45 termination plug, for example an 100 ohm RJ-45 ISDN terminator.

Note: *Do not use both of the DMX out connections, or both of the DMX in connections on a single fixture.*

If you are Stand-Alone programs (see “Stand-Alone programming overview” on page 22) on multiple fixtures on a data link and you experience random “flicker” or other unexplained control problems, insert a female termination plug (P/N 91613018) into the IN socket of the first fixture.

GENERAL OPERATION

When the 150W Single Base is connected to power it will reset. The text rSt will appear in the control panel display while this occurs. When the reset is completed the fixture address will appear in the control panel display.

The fixture can be operated using an external DMX control device or a stand-alone show can be programmed into the fixture directly.

EXTERNAL CONTROL

The 150W Single Base can be controlled with DMX signals from a DMX control device such as a DMX recorder or DMX controller. This is described in “Section 3. DMX control” on page 37.

STAND-ALONE PROGRAMMING

Using stand-alone programming, there are two ways of programming and storing a show in the fixture itself:

- Via the control panel, or
- Using the optional IR remote control (that communicates with the optional IR receiver mounted on the first fixture in a data link). This method is popular for installations of up to 10 fixtures because access to the various functions is faster, and because multiple fixtures can be simultaneously selected and programmed from a single IR remote control unit (this potentially time-saving method is known as IR Stand-Alone). If you have any MiniMac Maestro luminaires installed on the data link you can also use this method to program them.

Stand-Alone programming is described in “Section 2. Stand-Alone operation” on page 21.

CONTROL PANEL

The control panel is used to set the fixture address and other settings. It can also be used to develop a stand-alone program, and to operate the fixture in a limited way manually for testing and service purposes.

Navigating the control menu

The control panel displays the fixture address at the top of the menu. If there are any error messages these are displayed as well. To get to the top of the menu, press [menu] repeatedly. From the top, press [menu] to enter the main menu. Press [up] or [down] to scroll through menus and press [enter] to view submenus. To activate a setting or function, press [enter]. To return to the previous menu or to escape without making a selection, press [menu].



Inverting the display

Press [up] and [down] at the same time.

MENUS

The control panel menu is detailed in “Control menu structure” on page 52. They are described at a high level here.

Address menu (ADD)

Depending on the setting in the Profile menu (see “Profile menu (PRO)”), the Address menu is used to set either a:

- DMX control address (1-512), where a fixture will be controlled by DMX signals from a DMX control device.
- IR fixture ID number (0-9), where a fixture will be programmed using an IR remote control.

Profile menu (PRO)

The Profile menu contains three options where you can specify if the fixture is:

- Using the IR remote control system and has the IR receiver installed (rCS), or
- Using the IR remote control system and does not have the IR receiver installed (rCr), or
- Not using the IR remote (d1) system. Always specify this option when the optional IR remote control system is not in use.

Stand-alone menu (SA)

The Stand-Alone menu commands can be used to program and execute scenes in Stand-Alone mode. See “Programming using the fixture control panel” on page 25 for further information.

Adjustment menu (ADJ)

The Adjustment menu (ADJ) provides manual control for service use.

Personality menu (Per)

The Personality menu sets some basic characteristics, or the personality, that the fixture has.

LAMP-OFF AND RESET

These options enable you to disable the lamp-off and reset commands that are used on DMX channel 1. This might be useful if you are using a DMX control device with your 150W Single Base, because it reduces the chance of accidentally selecting lamp-off on channel 1 during a show.

AUTOMATIC LAMP-ON

When enabled, this will strike the lamp automatically within 90 seconds of applying power to the fixture. By default this is set to `Off`. If you are running a stand-alone program (`SA / Run = On`) that you want to start when the fixture is powered on, then this should be set to `On`.

DISPLAY

Turn off the display 2 minutes after the last key press or leave it on. This setting will be overridden by error and warning messages.

ENABLE LAMP OFF CONTROL FROM AN MC-X

When using an MC-X control device to select and run scenes, button 7 can be used to turn the lamp off.

ERRORS MESSAGE TOGGLE

This enables error messages to be suppressed. This enables, for example, the continued programming of a fixture that has a non-critical error. The default setting is On, which means that errors messages will not be suppressed and can be seen, when active, at the top level of the control menu structure.

TEMPERATURE WARNINGS

Allows temperature warnings to be enabled or disabled.

LAMP HOUR WARNING

Using this menu you can enables or disables lamp life warnings and set the number of hours of expected life that apply to the lamp type installed. A counter operates that can be read and reset in the `Inf` menu. When the resettable lamp hour counter reaches:

- 100 hours less than the predefined lamp hour warning level, the display will start blinking LHR in the display. At this point you should change the lamp to avoid the risk of lamp explosion.
- The predefined lamp hour warning level, the lamp shuts off and can not be turned on again before the counter is reset, or the predefined lamp hour warning level has been redefined.

STORE REMOTE STATUS (SRS)

This SRS option is only relevant when you are using the optional infrared remote control and receiver. If SRS is:

- On, and you start or stop the programmed show using the IR remote control, the fixture will additionally be set to automatically start or stop the show next time it is powered on.
- Off, the IR remote control has no influence over the automatic starting of a programmed show at power-on. This is controlled by the `SA / Run` menu (see “Starting show playback” on page 32).

RESTORE FACTORY DEFAULTS

Restores factory default settings in the Personality menu.

RESET ALL COUNTERS

Resets all resettable counters (these are found under the Information menu).

Information menu (INF)

The 150W Single Base provides readouts to track usage, temperature (in both the 150W Single Base and the Alien 02 luminaire), maintenance intervals, lamp life, and software version. Values from 1000 to 9999 are automatically scrolled and counters roll over to 0 when they reach 10,000.

DISPLAYING OR RESETTING A COUNTER

Scroll to `Inf` in the main menu, press [enter] and scroll to the desired readout. Press [enter] and scroll to the desired option. Press [enter] to display the information.

Note that the resettable counters (`RES`) in the `Inf` menu can be set to zero by pressing and holding [up] for approximately 5 seconds, until the readout displays 0.

Test menu (TST)

This is used by Martin service personal to test the printed circuit board.

SECTION 2. STAND-ALONE OPERATION

STAND-ALONE

PROGRAMMING OVERVIEW

In stand-alone mode, individual 150W Single Bases can be programmed to run a show of up to 20 scenes without an external controller. This can be done using the control panel or the optional IR remote control system.

The 150W Single Base will run its show in a continuous loop.

Multiple 150W Single Bases on a data link all have their own shows individually programmed, but can have scenes synchronously triggered by a one fixture on the data link.

ABOUT SCENE TIMING

Each scene has a dynamic part - the fade - during which effects move to the scene's programmed positions, and a static part - the wait - where effects do not change.

The duration of the fade and wait is programmed individually for each scene. The fade time may be 0 - 120 seconds; the wait time may be 0 - 600 seconds. The total time it takes a scene to execute is the sum of the fade and wait times.

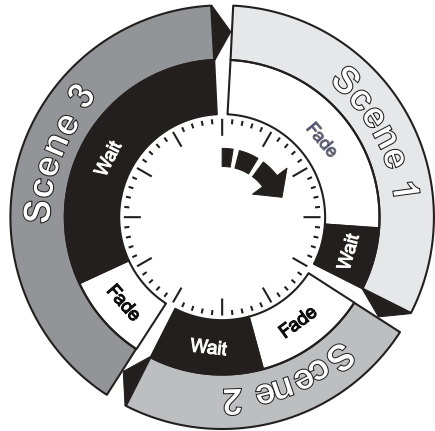

When operating multiple fixtures synchronously, the wait time is determined by the fixture that issues scene change commands. It does this when it reaches the end of each scene wait time. Every other fixture fades and waits at its own rate and then remains in the "wait state" until receiving a start scene xx command. When programming in synchronous triggering

situations, keep in mind that in order to keep things as simple as possible there are two rules of thumb that will make life much easier; try to ensure that:

- 1 Every fixture has the same number of scenes.
- 2 Respective scene times are a few seconds longer on the fixture that issues triggering commands.

The rules used in the algorithm are detailed in “Specifications” on page 57.

SYNCHRONIZING SCENE CHANGES FOR MULTIPLE 150W SINGLE BASES

In situations where you are running multiple 150W Single Bases on a data link it is possible to synchronize scene changes. Read this section if this applies in your case.

It is important to note that each individual fixture must be programmed with a show and that the only commands that are passed are scene change commands. No data about the look of the scene is passed between fixtures.

Setting synchronized triggering options

- 1 Scroll to **SA** in the top level of the menus on the control panel and press [enter].
- 2 Scroll to **SAE** and press [enter].
- 3 Select:
 - Sin** If the fixture will operate in isolation (with no synchronous triggering). This is the factory default setting.
 - Snd** If the fixture will send scene triggering signals to the other 150W Single Bases on the data link.
 - Syn** If the fixture should “listen” for scene trigger signals on the data link.
- 4 Press [enter].

PROGRAMMING METHODS

The 150W Single Base provides two stand-alone programming methods; using the:

- Fixture control panel. See “Programming using the fixture control panel” on page 25 for further information, or an
- MP-2 uploading device (refer to the *MP-2 user manual* for more information), or the
- Optional infrared remote control and infrared receiver. Using this method you can simultaneously select and program up to ten 150W Single Base fixtures on a single data link using a handheld remote. This method can save time programming individual fixtures. See “Programming using the optional infrared remote control” on page 28 for further information.

Note that it is always possible to perform stand-alone programming using the control menu on the fixture.

PROGRAMMING USING THE FIXTURE CONTROL PANEL

The control menus accessible via the 150W Single Base control panel can be used to program 20 scenes that make up a show. Note that:

- Every fixture can have up to 20 on-board scenes with individual fade & wait times.
- Scenes are numbered from 0 to 19.
- A scene contains a fade-section where the fixture shifts to the scene, followed by a wait-section where the scene effect is shown.

BEFORE YOU BEGIN PROGRAMMING

Stop the stand-alone program running:

- 1 Press [menu] to return to the top level of the menu.
- 2 Scroll to `SA` in the top level of the menus on the control panel and press [enter].
- 3 Scroll to `run` and press [enter].
- 4 Scroll to `Off` and press [enter].
- 5 Press [menu] to return to the top level of the menu.

If you are running multiple fixtures, ensure that:

- You have established a data link (see “Data linking multiple fixtures” on page 13).
- There is a termination plug in the last fixture in the data link.

STAND ALONE PROGRAMMING MENU (SA/PRG)

Use the Stand-Alone programming menu to create and store scenes. The paths described in this section can all be found under *SA / Prg* in the fixture control menu.

Scene “look” commands

SA/Prg	Int	0-255	Set intensity level (0 = closed).
	CyA	0-255	Set Cyan level
	nnA	0-255	Set magenta level
	yEL	0-255	Set Yellow level
	rAC	OFF	Disable random colors
	aLL	SLO	Set random colors, slow
		nnE	Set random colors, medium
		FAS	Set random colors, fast
	Cnn	SLO	Set random bluish colors, slow
		nnE	Set random bluish colors, medium
		FAS	Set random bluish colors, fast
	nny	SLO	Set random reddish colors, slow
		nnE	Set random reddish colors, medium
		FAS	Set random reddish colors, fast
	Cy	SLO	Set random greenish colors, slow
		nnE	Set random greenish colors, medium
		FAS	Set random greenish colors, fast

Scene timing commands

SA/Prg	FAd	SnA	Set scene fade time to zero.
		1-120	Set scene fade time in seconds
	uuA	0-600	Set scene wait time in seconds

Scene management commands

SA/Prg	Add		Save scene to end of sequence
	nE		Call next scene
	PrE		Call previous scene
	StO		Save changes to current scene
	InS		Insert scene before current scene
	dEL		Delete current scene
	CLr	nO	Cancel command
		yES	Delete all scenes (scene 0 and reload default)
	UIE		Test run the currently stored scenes in the pre-programmed show once.
	Gd		Capture DMX levels from a connected DMX control device. You can use a controller to set a scene, capture it with this menu command, and then store it as a scene.

Note *Control panel actions sometimes result in updates to the fixture's memory. If the fixture is powered off during this process updates may be lost. A "Memory not yet stored" warning indicator appear as a blinking red dot in the left side of the control panel display during memory update. Do not power the fixture off while this is lit.*

PROGRAMMING USING THE OPTIONAL INFRARED REMOTE CONTROL

Programming can be performed using an optional infrared transmitter and receiver system that are orderable from your Martin dealer. Infrared programming can be performed for a single fixture, or up to 10 fixtures on a data link.

The optional IR remote control device can be used to program 20 scenes that make up a show. Note that:

- Every fixture can have up to 20 on-board scenes with individual fade & wait times.
- Scenes are numbered from 0 to 19.
- A scene contains a fade-section where the fixture shifts to the scene, followed by a wait-section where the scene effect is shown.
- Programming using the IR remote control is easiest when the display on the 150W Single Base control panel can be seen.

You can also program any MiniMAC Maestro fixtures on the same data link. Refer to the *MiniMAC Maestro user manual* for further information.

Note that it is always possible to perform stand-alone programming using the control menu on the fixture, or using an MP-2 uploading device (refer to the *MP-2 user manual* for more information).

BEFORE YOU BEGIN PROGRAMMING

If you are running multiple fixtures, ensure that:

- You have established a data link (see “Data linking multiple fixtures” on page 13).
- There is *no* termination plug in the last fixture in the data link.

Ensure the stand-alone program is not running

To stop the current stand-alone program running:

- 1 Press [menu] to return to the top level of the menu.
- 2 Scroll to SA in the top level of the menus on the control panel and press [enter].
- 3 Scroll to run and press [enter].
- 4 Scroll to Off and press [enter].
- 5 Press [menu] to return to the top level of the menu.

Enabling infrared programming

Perform the following steps in this order:

- 1 Only the first fixture on the data link can have an IR receiver. Insert the receiver module into the serial data In socket. Position the sensor arm as desired but avoid turning it more than necessary.
- 2 From the top level of the menu, scroll to Pro, press [enter].
- 3 If this fixture:
 - Does not have the IR receiver installed, scroll to rCr. Press [enter].
 - Has the IR receiver installed, scroll to rCS. Press [enter].
- 4 Press [menu] to return to the top level of the menu.
- 5 Select Addr and press [enter]. Select an IR fixture address from 0 to 9 and press [enter]. Note that if you have multiple fixtures that will run the same stand-alone scenes it might be a good idea for them to share the same IR fixture address. This will save time when programming, as they will all receive and process the scene programming instructions simultaneously.
- 6 Press [menu] to return to the top level of the menu.
- 7 Stand 2 meters (6 ft.) away from the fixture, point the remote control at the receiver, and press the lamp power button. If there is no response, try the ID button. If there is still no response, reverse the sensor head by rotating the sensor arm 180° and folding it over.

REMOTE CONTROL COMMANDS

Important! *The luminaire will acknowledge the receipt each valid IR command with a slight change in intensity.*

Fixture selection

Each fixture must be assigned an address from 0 - 9 during setup so that it can be individually controlled with the remote control. Note that fixtures can share an address if they are to have the same program.

To select a fixture, press ID and enter its address using the number keys. Multiple fixtures may be selected by entering more than one address. For example, pressing [ID] [1] [2] [3] selects fixtures 1, 2, and 3.

Lamp power

The lamp power button toggles lamp power on and off on selected fixtures. The button must be held for 5 seconds to turn lamp power off. Note: Lamps cannot be turned off during scene execution and a discharge lamp must cool for several minutes after being turned off before it can be turned back on.

Scene timing

Fade and wait times are set by pressing the scene timing buttons and entering the desired time in seconds using the number keys.

Scene Selection

Scenes are created, selected, saved, and deleted using the six scene keys. The current scene is displayed on the fixture display after the letter “r” during editing and after the letter “P” during execution.

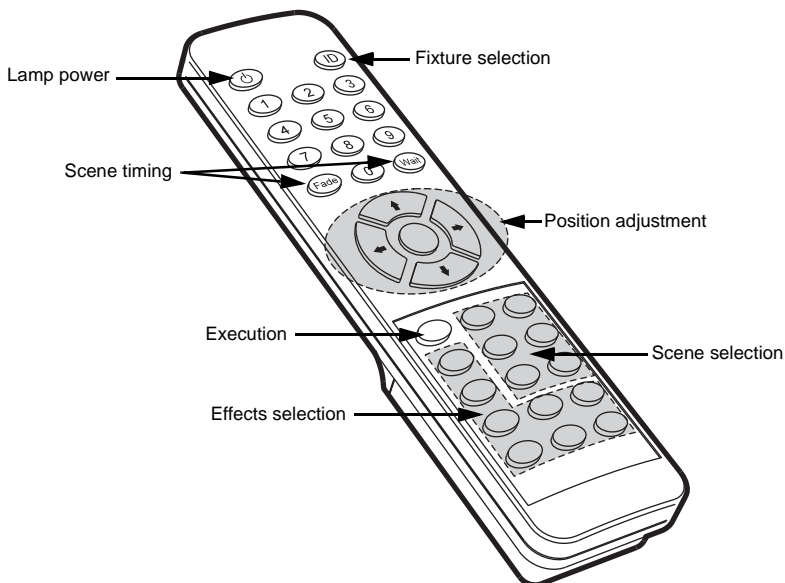

- **Prev** (previous scene) scrolls backwards through scenes on selected fixtures.
- **Next** (next scene) scrolls forwards through scenes on selected fixtures.
- **Store** (store scene) saves effect and timing settings to the current scene.
- **Delete** (delete scene) removes the current scene from memory. Scenes above the deleted scene are renumbered.
- **INS** (insert scene) creates and saves a new scene before the current scene, which moves up a number.
- **ADD** (add scene) creates a new scene at the end of the sequence with the settings that are active when the scene is created.

00 01 02

Store saves settings in the current scene.

00 01 02 03

Add saves settings in a new scene at the end of the sequence.

00 01 02 03

Insert saves settings in a new scene before the current scene.

Effects Adjustment

The look of a scene is programmed by first selecting an option with the effect selection buttons and then adjusting the option with the position adjustment buttons. When two effects are assigned to a selection button, the up/down arrows control one effect and the left/right arrows control the other effect. If there is only one effect, the up/down arrows usually provide course adjustment and the left/right arrows usually provide fine adjustment. The middle button returns effects to a default position.

STAND-ALONE SHOW PLAYBACK

STARTING SHOW PLAYBACK

- 1 From the top level of the menu, scroll to `SA` and press [enter].
- 2 Scroll to `SA` in the top level of the menus on the control panel and press [enter].
- 3 Scroll to `run` and press [enter].
- 4 Scroll to `On` and press [enter].

When the show starts to run the current scene number will appear in the control panel display (unless the `Per/dIS` menu has been set to `OFF`, in which case the display will switch off two minutes after the last key is pressed).

Important! ***Execution of the pre-programmed scenes in a loop will automatically resume when the fixture is powered-on if stand-alone is enabled and the automatic lamp-on (Per/ALO) function is enabled (see “Automatic lamp-on” on page 17).***

SHOW EXECUTION WITH THE IR REMOTE CONTROL

The Run/Stop button on the IR remote control toggles scene execution on/off on fixtures that are selected (see “Fixture selection” on page 30). Scenes execute in a continuous ascending loop.

All remote control functions except Run/Stop are disabled during show execution.

If the Store Remote Status option (see “Store remote status (SRS)” on page 18) is enabled, then the Run/Stop button will also toggle the `SA / run` option to `OFF` or `On`, so that next time the fixture is powered on it will automatically start (or not start) the Stand-Alone show.

SCENE EXECUTION USING THE OPTIONAL MC-X

The MC-X is an optional remote control unit that is available from Martin. Once the remote controller is connected, 7 scenes can be conveniently called up on the MC-X's buttons.

To enable control:

- 1 Connect the MC-X controller to the 150W Single Base's data input. If multiple 150W Single Bases are connected, plug the controller into the first fixture in the link.
- 2 On each fixture, select `SA / run / OFF` and press [enter]. Press [menu] to exit the `SA` menu.
- 3 On each fixture, select `PrO / d1` and press [enter]. Press [menu] to exit the `PrO` menu.
- 4 To trigger scenes 00-06, press the numbered preset buttons on the MC-X.
- 5 To have each fixture run its own routine, press [Auto].

Using the `Per / nnO` menu it is possible to set button 7 on the MC-X to control the lamp off function. See "Control menu structure" on page 52.

DMX CONTROLLER OVERRIDE DURING STAND-ALONE SHOW PLAYBACK

If a 150W Single Base is connected to a DMX controller and receives DMX signals during show playback, the Stand-Alone show will stop running and the fixture will respond to the DMX controller. DMX signals always have priority over the running of a Stand-Alone show.

RULES FOR SYNCHRONOUS TRIGGERING DURING STAND- ALONE OPERATION

Note: *This chapter details the rules that are used in Stand-Alone synchronous triggering. It is not necessary to read this chapter unless you require help with problem diagnosis or unless you otherwise need a detailed understanding of the algorithm used for synchronous triggering.*

The rules are as follows:

- 1 Every fixture can have up to 20 on-board scenes with individual fade and wait times.
- 2 Scenes are numbered from 0 to 19.
- 3 A scene contains a fade-section, followed by a wait-section.
- 4 When running "synchronous triggering" one 150W Single Base issues commands to the other 150W Single Bases to "go to scene xx", where xx is the scene number that master will execute next.
- 5 If a slave has fewer scenes than the master, it will derive which scene to go to by dividing the number of the scene it has been commanded to go to (scene 5, for example) by the total number of scenes that the slave fixture has (4, for example) in whole numbers (no decimal places). In this example 5 divided by 4 results in 1, with 1 remainder. This remainder will be the number of the scene that the slave fixture starts - scene 1. Generally though, when a Slave fixture reaches its own last scene before the Master fixture, a "go to scene x" message will result in the first scene being played.

- 6 If a slave has more scenes than the master calls, the last scenes in the slave will never be executed, as is the case with scene S4 in the following example.

F=fade, W=wait

Timeline =>

Programmed in Master	M0	M1	M2	M3	
	F W	F W	F W	F W	
Programmed in Slave	S0	S1	S2	S3	S4
	F W	F W	F W	F W	F W
Result	M0	M1	M2	M3	
	F W	F W	F W	F W	
	S0	S1	S2	S3	
	F W	F W	F W	-- -- F W	

- 7 A slave fixture will not listen for the next message from the master fixture before it has finished its current scene. This may result in a slave skipping a scene if slave has a longer scene time than master. Note that in the following example the scenes in the Slave run out of their programmed sequence because scenes 0 and 2 on the Slave are longer than the corresponding scenes on the Master.

M=master, S=slave

F=fade, W=wait **Time >**

Programmed	M0	M1	M2		
	F W	F W	F W		
Master	S0	S1	S2		
	F W	F W	F W		
Slave	M0	M1	M2	M0	M1
	F W	F W	F W	F W	F W
Result	S0	S2	S1		
	F W	F W	-- -- F W	-- --	

SECTION 3. DMX CONTROL

DMX CONTROLLER

OPERATION

The 150W Single Base may be programmed and operated with any lighting control device that is compatible with the USITT DMX standard. This section describes how to operate the system with a controller. See “Specifications” on page 57 for specific control values.

CONNECTING A DMX CONTROL DEVICE

Connect a data cable to the controller’s data output. If you are using XLR connectors and the controller has a 5-pin output, use a 5-pin male to 3-pin female adaptor cable (P/N 11820005). Lead the cable from the controller to the first 150W Single Base and plug it into the data input.

CONTROL ADDRESS SELECTION

The 150W Single Base requires 7 DMX control channels. The DMX address, also known as the start channel, is the first control channel used. It is a logical address to which control instructions are sent. In this way a controller, can send instructions to a fixture, or fixtures, at a particular address. For example when using seven channels of control data, the 150W Single Base reads the data on the start channel (DMX address) and the next six channels. If the DMX address is set to 100, the 150W Single Base uses channels 100, 101, 102, 103, 104, 105, and 106.

Be sure to allow adequate channels when setting the control address. If control channels for one fixture overlap control channels for another fixture, then one of the fixtures will receive the wrong commands. Two 150W Single Bases may share the same address if they are to respond identically. They will receive the same commands and individual control will be impossible.

The default factory set control address is ‘1’.

Setting the control address

- 1 Scroll to `PrO` in the top level of the menus on the control panel and press [enter].
- 2 Select `d1` to enable DMX control. Press [enter].
- 3 Press [menu] to return to the top level of the menu.
- 4 Scroll to `Adr` in the top level of the menus on the control panel and press [enter]. The current address is displayed.
- 5 Scroll to the address that is assigned to the fixture on the controller. Press [enter] to activate the address setting.

DISABLE STAND-ALONE OPERATION (IF REQUIRED)

DMX control always overrides any Stand-Alone show that is running, but if Stand-Alone mode is enabled and no DMX signal is received, the 150W Single Base will attempt to run any show in its memory. To prevent this:

- 1 Press [menu] to return to the top level of the menu.
- 2 Scroll to `SA` in the top level of the menus on the control panel and press [enter].
- 3 Scroll to `run` and press [enter].
- 4 Scroll to `Off` and press [enter].

LAMP CONTROL

Important ***Avoid striking several lamps at once!***

The lamp can be turned on and off from the controller using the lamp-on and lamp-off commands on channel 1. To prevent accidental lamp-off commands, lamp off can be partially disabled from the using the `Per / LOF` menu on the control panel (see “Control menu structure” on page 52). If the DMX Lamp-off personality is off, the lamp-off command on channel 1 executes only if each of the CMY channels (3, 4, and 5) is set to a DMX value from 230 to 232.

Strike lamps one at a time at 5 second intervals. Striking many lamps at once may cause a voltage drop large enough to prevent lamps from striking, damage electronics, and trip circuit breakers. To have the lamp strike

automatically at power-up, set the Automatic Lamp-on personality to on (see “Personality menu (Per)” on page 17).

The lamp must be allowed to cool for several minutes after turning it off before it can be turned back on. If a hot lamp does not strike, send the lamp off command and wait several minutes before trying again.

EFFECTS

The mechanical effects reset to their home positions when the fixture is powered on. Effects can also be reset from the controller on channel 1. If the DMX Reset personality is off, the reset command on channel 1 executes only if each of the CMY channels is set to a DMX value from 230 to 232.

Intensity

The fixture provides smooth, high resolution, full-range intensity control on channel 2.

CMY subtractive color mixing

The CMY color mixing system is based on cyan, magenta, and yellow color filters. A continuous range of colors may be achieved by varying the amount of each filter from 0 to 100% on channels 3, 4, and 5. To execute specific color values, channel 6, random color mixing, must be set to 0%.

Note that mixing 3 colors results in a loss of light - *the light is blacked out when all 3 colors are fully applied*. For maximum brightness, mix only 2 colors at a time.

If you have Exterior 600 and Exterior 200 fixtures rigged in the same installation then refer to “Service” on page 44.

Random color mixing

Random color mixing at slow, medium, and fast speeds is available on channel 6. The colors can be mixed from any two, or all three, of the primary subtractive colors. Choosing a random mixing of just two of the primary subtractive colors will result in the following types of tones:

Combination	Result
Cyan & magenta	Bluish tones
Cyan & yellow	Greenish tones
Magenta & yellow	Reddish tones

These random commands take precedence over values set on the cyan, magenta, and yellow channels.

Effect speed

The speed at which effects fade, that is, move from one position to another, can be controlled in two ways known as tracking control and vector control. You may switch between tracking and vector control, but you cannot use both at the same time.

Tracking control is enabled by setting channel 7, the speed channel, to a decimal value from 0 to 2. Fades are then programmed using the controller's cross-faders. The 150W Single Base has a digital filter algorithm that averages several updates to ensure smooth movement.

Vector control provides a way to program fades on controllers without cross-faders and may provide smoother fades than tracking control with some controllers, particularly on very slow fades. A vector speed is programmed by setting channel 7 to a decimal value from 3 (fastest) to 245 (slowest). The speed setting applies to intensity control and color fades. When using vector control, the controller cross-fade time, if available, must be 0.

DMX PROTOCOL

Start code = 0

DMX channel	Value	Percent	Function
1	0 - 207	0 - 81	Reset, Lamp On/Off
	208 - 217	82 - 85	Reserved (no change)
	218 - 227	85 - 89	Reset fixture
	228 - 237	89 - 93	Reserved (no change)
	238 - 247	93 - 97	Lamp power on
	248 - 255	97 - 100	Reserved (no change) Lamp power off* Note: T ≥ 5 seconds
2	0 - 255	0 - 100	Intensity Closed → open
3	0 - 255	0 - 100	Cyan White → Cyan
4	0 - 255	0 - 100	Magenta White → Magenta
5	0 - 255	0 - 100	Yellow White → Yellow
6	0 - 14	0 - 5	Random Color Mixing
	15 - 34	5-13	Off
	35 - 54	13-21	CMY, slow
	55 - 74	21-29	CMY, medium
	75 - 94	29-37	CMY, fast
	95 - 114	37-44	MY, slow
	115 - 134	45-52	MY, medium
	135 - 154	53-60	MY mix, fast
	155 - 174	61-68	CM, slow
	175 - 194	68-76	CM, medium
	195 - 214	76-84	CM, fast
	215 - 234	84-92	CY, slow
	235 - 255	92-255	CY, medium
7	0 - 2	0 - 1	Speed
	3 - 245	1 - 96	Tracking
	246 - 251	96 - 98	Fast → slow
	252 - 255	99 - 100	Reserved (no change)
			Fast

SECTION 4. SERVICE AND TROUBLESHOOTING

SERVICE

This section describes service procedures that can be performed by the user. Refer all service not described here to a qualified Martin technician.

Warning! *Disconnect the fixture from power before removing any cover.*

CLEANING

Wash the aluminum housing of the 150W Single Base with a soft brush or sponge and a mild, non-abrasive car washing detergent. Rinse.

You can use a vacuum cleaner on low suction to clean the fan.

FIRMWARE UPDATES

Firmware updates are released when features are added. The latest version is available from the Support Area of the Martin Professional web site at <http://www.martin.dk>.

The installed firmware version number is displayed in the control panel under the INF/UEr menu.

REQUIREMENTS

Firmware is installed using one of the following hard ware devices:

- Martin MP-2 Uploader
- One of the DMX interfaces for the Martin LightJockey controller.

The following are required in order to install software:

- The 150W Single Base update file, available for download from the User Support Area of the Martin web site (<http://www.martin.dk>).
- The MP-2 Software Uploader program, version 5.0 or later, available for download from the User Support Area of the Martin web site, or a LightJockey Controller

Refer to the LightJockey user documentation for the procedure for uploading using the LightJockey.

The procedure for preparing the MP-2 is found in the *MP-2 user manual* and the Martin Software Uploader online help file. Follow these instructions before proceeding to the next section.

Updating fixture firmware with the MP-2 Uploader

- 1 Connect a prepared MP-2 Uploader to the DMX link on the 150W Single Base. Apply power to the fixtures and the MP-2. Wait a few moments for the fixtures to reset.
- 2 Select `Read Memory Card` from the MP-2 main menu.
- 3 Use the buttons on the right to scroll through the card slots. Select the slot that holds the desired version of the 150W Single Base firmware.
- 4 Select `Update Software`. Select `Yes` to confirm.
- 5 Select `Update in DMX mode` to start the upload. The MP-2 initializes all connected 150W Single Bases.
- 6 After a successful upload the fixtures reset with the new software. If an error occurs and the fixtures do not reset, data was interrupted or corrupted during transmission. Perform a boot mode upload as described in the following section.

BOOT SECTOR UPLOAD

If the normal upload procedure does not work, or if the software update notes call for a boot sector update, move the boot sector jumper in the 150W Single Base at PL12 to the BOOT ENABLE position before uploading software.

Performing a boot sector update

- 1 Make sure the 150W Single Base is isolated from AC power.
- 2 Open the cover using a 2.5 mm Allen wrench.
- 3 Referring to “Specifications” on page 57, locate the jumper at position PL12. Move the jumper to the “ENABLE” position (the two pins closest to the fuses on the printed circuit board).
- 4 Perform a boot mode upload as described in the uploader manual.
- 5 When the upload is complete, disconnect the fixture from power and move the jumper at PL12 back to the “DISABLE” position (the two pins farthest away from the fuses on the printed circuit board).
- 6 Replace the cover.

FUSE REPLACEMENT

Warning! *Never replace fuses with ones of a different rating!*

The main fuse is a 3.15 AT fuse located in a holder above the **MAINS INPUT** socket.

Replacing the main fuse

Main fuse replacement requires a small flat-head screw driver.

To replace a fuse:

- 1 Open the fuse holder just above the MAINS INPUT socket using a small flat-head screwdriver to open it. The holder may be packed with the other fuse.
- 2 Insert the correct fuse and place the holder back in the **MAINS INPUT** socket.

TROUBLESHOOTING

Problem	Probable cause(s)	Remedy
No response from fixture when power is applied.	No power to fixture.	Check power and data cables.
	Primary fuse blown.	Replace fuse.
Fixture resets but does not respond correctly to controller (DMX mode operation).	Controller not connected.	Connect controller.
	Incorrect addressing of the fixtures.	Check address setting on fixture and controller.
	Bad data link connection.	Inspect cables and correct poor connections and/or broken cables.
	Conflict between tracking and vector control.	Eliminate scene cross-fade on controller or set ch. 7 to 0%.
	Data link not terminated.	Insert termination plug in output of last fixture.
	Defective fixture or 2 devices transmitting on link.	Bypass fixtures one at a time until normal operation is regained: unplug both connectors and connect them directly together.
Fixture does not reset correctly.	Electronic or mechanical failure.	Contact service technician.
No light, lamp cuts out intermittently, or burns out too quickly.	Lamp missing or blown.	Disconnect fixture and replace lamp.
	Fixture or lamp is too hot.	Allow fixture to cool. If problem persists, contact service technician.
	Incorrect power supply setting.	Check setting.

ERROR MESSAGES

Message in display	Error	Remedy
EEE	EPROM error	Contact your Martin dealer for service.
rAE	Memory error	Contact your Martin dealer for service.
FPE	FPGA error	Contact your Martin dealer for service.
d r E	Driver error	Update the firmware. See "Firmware updates" on page 44. If updating the firmware does not help, then contact your Martin dealer for service.
tAE	Temperature in Alien 02 luminaire too high.	Contact your Martin dealer for service.
t b E	Temperature in 150W Single Base too high.	Check that the fan is functioning and that there is enough space around the air vent. Check that the ambient temperature does not exceed 40° C (104° F). Contact your Martin dealer for service.
LHr	Lamp has less than 100 hours until the end of its expected life.	Change the lamp in the Alien 02 luminaire.

PRINTED CIRCUIT BOARD LAYOUT

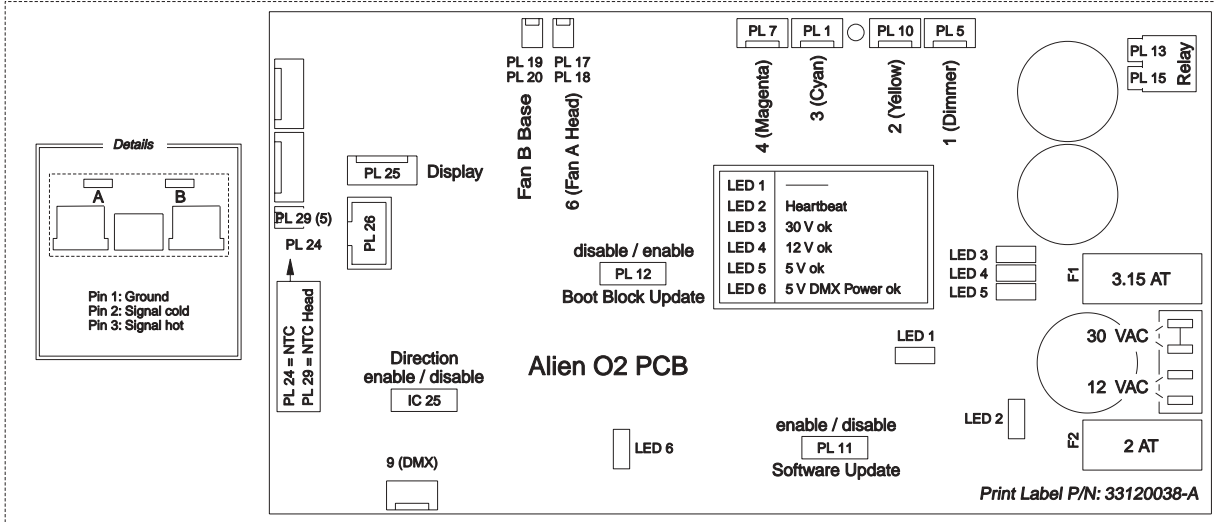

SECTION 5. REFERENCE

CONTROL MENU STRUCTURE

Default settings appear in bold.

Level 1	Level 2	Level 3	Level 4	Level 5	Effect (default = bold)
Adr	DMX: 1-512 IR: 0-9				Select control address for both DMX and IR profile. (IR address is selectable when PrO/rCS or PrO/rCr are selected. DMX address is selectable when PrO/d1 is selected)
PrO	d1				IR not used (choose for DMX, or whenever infrared is not used).
	rCS				Set IR-remote control "send" mode. The fixture has an IR receiver device installed and will send programming and triggering signals to other 150W Single Base fixtures on the data link. Only one fixture on the data link may have this set.
	rCr				Set IR-remote control "recieve" mode. The fixture will listen for programming and scene triggering information. All 150W Single Base fixtures on the data link that do not have an IR receiving device installed are set to rCr.

Table 2: Control menu structure

SA	run	OFF		Stop execution of the stand alone program.	
		On		Execute the stand alone program. When the fixture is powered-on the stand-alone program will start automatically.	
	SAE	Sin		Fixture operates in isolation	
		Snd		Fixture is set master for program operation	
		Syn		Fixture is set to synchronized program operation	
	Prg	Int	0-255	Set intensity level (0 = closed)	
		CyA	0-255	Set Cyan level	
		nnA	0-255	Set magenta level	
		yEL	0-255	Set Yellow level	
		rAC	OFF		Disable random colors
			aLL	SLO	Set random colors, slow
				nnE	Set random colors, medium
				FAS	Set random colors, fast
			Cnn	SLO	Set random bluish colors, slow
				nnE	Set random bluish colors, medium
				FAS	Set random bluish colors, fast
			nny	SLO	Set random reddish colors, slow
				nnE	Set random reddish colors, medium
		FAS		Set random reddish colors, fast	
		Cy	SLO	Set random greenish colors, slow	
			nnE	Set random greenish colors, medium	
			FAS	Set random greenish colors, fast	
		FAd	SnA		Set scene fade time to zero.
			1-120		Set scene fade time in seconds
		uuA	0-600		Set scene wait time in seconds
		Add			Save scene to end of sequence
		nE			Call next scene
		PrE			Call previous scene
		StO			Save changes to current scene
		InS			Insert scene before current scene
dEL				Delete current scene	
CLr		nO		Cancel command	
	yES		Delete all scenes (scene 0 and reload default)		
UIE			Run program		
Gd			Capture DMX levels		

Table 2: Control menu structure

ADJ	rSt			Reset effects to home position
	LOn			Turn lamp on
	LOF			Turn lamp off
	ALL	OPn		Move all effects to open position
		CLO		Move all effects to closed position
	Int	OPn		Intensity 100%
		CLO		Intensity 0%
	CyA	OPn		Move cyan flag to open position
		CLO		Move cyan flag to closed position
	nnA	OPn		Move magenta flag to open position
		CLO		Move magenta flag to closed position
	yEL	OPn		Move yellow flag to open position
		CLO		Move yellow flag to closed position

Table 2: Control menu structure

Per	LOF	OFF			Disable lamp off without confirmation
		On			Enable lamp off without confirmation
	rES	OFF			Disable reset without confirmation
		On			Enable reset without confirmation
	ALO	OFF			Strike lamp from controller or display
		On			Automatically strike lamp within 90sec from power on.
	dIS	OFF			Turn display off 2 minutes after key press
		On			Keep display lit
	SrS	OFF			The Run/Stop button on the IR remote control does not affect the setting on the SA / run option. See “Store remote status (SRS)” on page 18.
		On			The Run/Stop button on the IR remote control also toggles the SA / run option on or off. See “Store remote status (SRS)” on page 18.
	nnO	OFF			Disable MC-X lamp off. See “Scene execution Using the optional MC-X” on page 33.
		On			Enable MC-X button 7 lamp off. See “Scene execution Using the optional MC-X” on page 33.
	Enn	OFF			Error warnings disabled
		On			Error warnings enabled
	tE	OFF			Temperature warnings disabled
		On			Temperature warnings enabled
	LHr	OFF			Lamp hour warning disabled
		On	0.1-99.9		Enable lamp hour warning and set value [1.000h]
	FAC				Restore default factory settings
	rEC				Reset all counters.

Table 2: Control menu structure

INF only display not MP2	UEr				Read firmware version number
	tEL	CUr			Read current temperature in lamp [×C]
		tOt			Read maximum temperature in lamp since fabrication [×C]
		rES			Read maximum temperature in lamp since reset [×C]. Press and hold the [up] button for 5 seconds to reset.
	tEb	CUr			Read current temperature in base [×C]
		tOt			Read maximum temperature in base since fabrication [×C]
		rES			Read maximum temperature in base since reset [×C]. Press and hold the [up] button for 5 seconds to reset.
	Hr	tOt			Read power-on hours since fabrication
		rES			Read power-on hours since counter was reset. Press and hold the [up] button for 5 seconds to reset.
		UAL			Read set value for warning
	LHr	tOt			Read lamp hours since fabrication
		rES			Read lamp hours since counter was reset. Press and hold the [up] button for 5 seconds to reset.
		UAL			Read set value for warning
	LSt	tOt			Read lamp strikes since fabrication
		rES			Read lamp strikes since counter was reset. Press and hold the [up] button for 5 seconds to reset.
tSt	Pcb			Test PCB. For service use only	

Table 2: Control menu structure

SPECIFICATIONS

PHYSICAL

Length: 298 mm (11.7 in)
Width: 214 mm (8.4 in)
Height: 91 mm (3.6 in)
Weight: 5.7 kg (12.6 lbs)

CONTROL & PROGRAMMING

Control options: DMX-512
Receiver: RS-485
Setting and addressing: 3-digit LED control panel, remote w/ uploader
Firmware update: serial upload (MUF)
Data input: 3-pin XLR male, RJ-45
Data output: 3-pin XLR female, RJ-45
Data pinout: pin 1 shield, pin 2 cold (-), pin 3 hot (+)

INSTALLATION

Minimum distance to combustible materials: 1 m (39 in)
Minimum distance to illuminated surfaces: 0.5 m (20 in)
Orientation: any
Standard cable separation between Alien 02 Spot and 150W Single Base: 1 m (40 in)

THERMAL

Maximum ambient temperature (Ta): 40° C (104° F)
Maximum surface temperature, steady state, Ta=40° C: 80° C (176° F)

AC SUPPLY

AC input: 3-pin IEC male socket
Power supply options: 100/120/210/230/250 V, 50/60 Hz

CONSTRUCTION

Housing: Aluminum

ORDERING INFORMATION

Alien 02 Spot: P/N 90345000
150W Single Base: P/N 90724000
Alien 02 Spot 135 mm (5.3 in) mounting arm: P/N 91611048

ACCESSORIES

Martin infrared remote control transmitter.....	P/N 90760010
Martin infrared remote control receiver.....	P/N 91611047
MP-2 uploader:.....	P/N 90758420
2-meter cable extension kit.....	P/N 91611051
5-meter cable extension kit.....	P/N 91611060
10-meter cable extension kit.....	P/N 91611061
MC-X Controller, 220-245V/50Hz.....	P/N 90718200
MC-X Controller, 110-120V/60Hz.....	P/N 90718300

INCLUDED ITEMS

User manual
3 meter (9.8 ft), 3-pin IEC mains cable
5 meter (16.4 ft), black, 3-pin XLR data cable