



Imager Series



user manual

Measurements are in millimeters

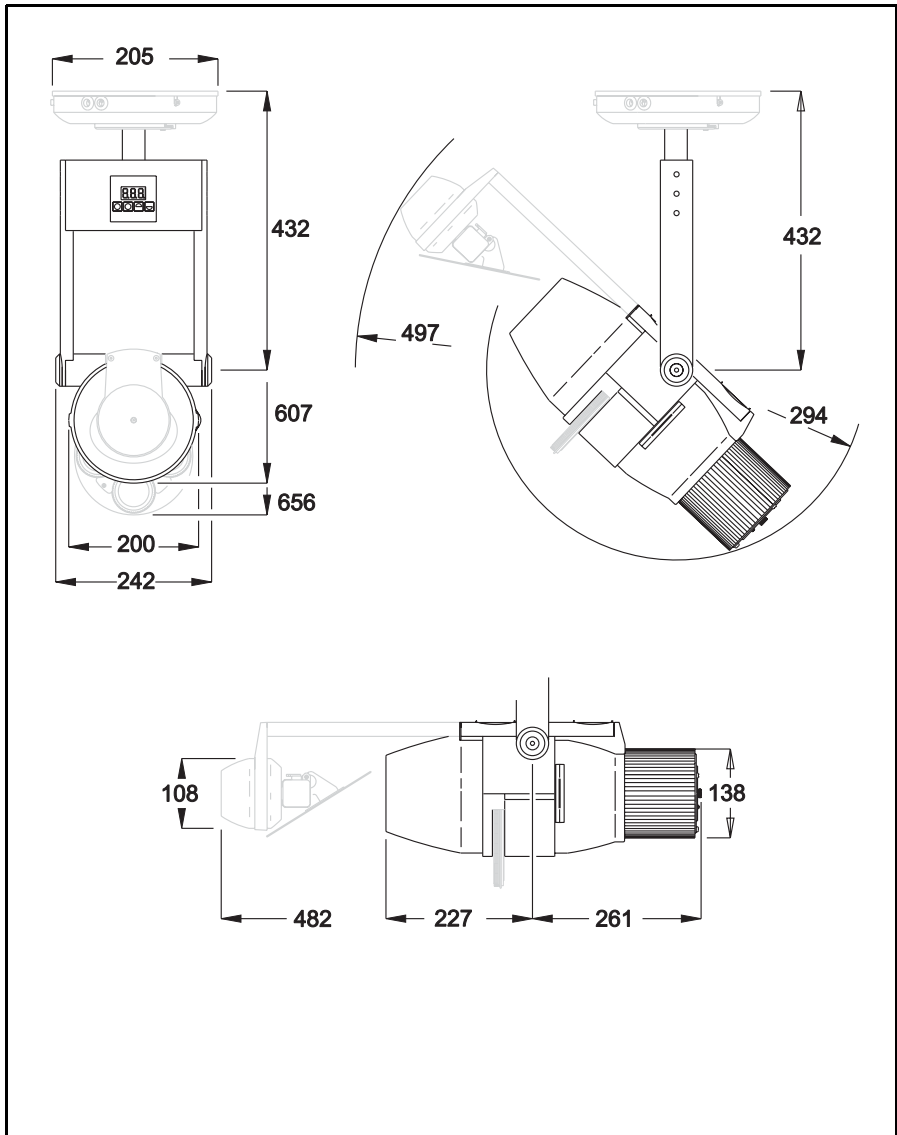

© 2003 Martin Professional A/S, Denmark.

All rights reserved. No part of this manual may be reproduced, in any form or by any means, without permission in writing from Martin Professional A/S, Denmark.

Printed in Denmark.

P/N 35000127, Rev A1

SECTION 1. GETTING STARTED..... 5

INTRODUCTION 6
 Safety information 6
 Task checklist. 8

INSTALLATION 9
 Unpacking 9
 Configuration overview. 9
 Mounting orientation and location 10
 Power. 13
 Data linking multiple fixtures 14

GENERAL OPERATION 16
 External control 16
 Stand-Alone programming 16
 Control panel 17
 Menus 17

SECTION 2. STAND-ALONE OPERATION 23

STAND-ALONE PROGRAMMING OVERVIEW 24
 About scene timing. 24
 Synchronizing scene changes for multiple Imagers. 25
 Programming methods. 26

PROGRAMMING USING THE OPTIONAL INFRARED REMOTE CONTROL 27
 Before you begin programming 27
 Remote control commands 29

STAND-ALONE SHOW PLAYBACK 31
 Starting show playback 31
 Show Execution with the IR remote control 31
 Scene execution Using the optional MC-X. 32
 DMX controller override during Stand-Alone show playback. 32

SYNCHRONOUS TRIGGERING DURING STAND-ALONE OPERATION . 33

SECTION 3. DMX CONTROL 35

DMX CONTROLLER OPERATION. 36
 Connecting a DMX control device 36
 Set the appropriate DMX mode 36
 Control address selection. 37

Disable Stand-Alone operation (if required)	37
Lamp control	38
Effects	38
SECTION 4. OPTICS AND PROJECTION ACCESSORIES.....	41
GOBOS.	42
Image projection size	42
Custom gobos	42
Replacing a gobo	44
Imager DMX Gobo Wheel	45
FILTERS	47
LENS OPTIONS	48
Changing the lens	48
MOVING MIRROR	50
SECTION 5. SERVICE AND TROUBLESHOOTING	53
SERVICE.	54
Lamp replacement	54
Cleaning	55
Firmware updates	56
PRINTED CIRCUIT BOARD LAYOUT	59
TROUBLESHOOTING	60
Error messages	60
SECTION 6. REFERENCE.....	63
CONTROL MENU STRUCTURE.	64
DMX PROTOCOLS.	68
Imager DMX-Gobo Wheel	69
Imager DMX-Gobo Wheel with moving-mirror fitted	70
Imager DMX-Gobo	72
Imager DMX-Gobo with moving-mirror fitted	73
SPECIFICATIONS - IMAGER	75

SECTION 1. GETTING STARTED

Introduction

Thank you for selecting the Martin Imager. The Imager is a series of luminaires designed for high resolution projection of patterns, images, logos and messages. Imager luminaires are dedicated projectors suited to low-maintenance installations.

The Imager product range is made up of a number of luminaires and accessories:

- Imager DMX Gobo Wheel - a DMX controlled four-gobo projector
- Imager DMX Gobo - a DMX controlled single gobo projector
- Imager Base - provides power to a single Imager luminaire
- Imager J-box - Imager mounting device
- Moving mirror for Imager

Imager luminaires use a 250W discharge lamp. Three available lens options offer the choice of narrow, medium and wide beam angles. DMX control enables remote focus and control of effects. For colored projections there is a simple slot for easy-to-replace color filters. The Imager is also equipped with a dimming system designed to create gentle fades and transitions.

The optional moving mirror provides programmable movement, useful for roving logos or gliding messages. This attachment creates the possibility of precise, smooth movement in a range of 235° of pan by 65° of tilt. Fixture settings are controlled via a 3-digit control panel or with an optional infrared remote control.

Safety information

Warning! *This product is for professional use only. It is not intended for use in a dwelling.*

This product presents risks of lethal or severe injury due to fire and heat, electric shock, ultraviolet radiation, lamp explosion, and falls. Read this manual before powering or installing the fixture, follow the safety precautions listed below and observe all warnings in this manual and on the fixture. If you have questions about how to operate the fixture safely, please contact your Martin dealer or call the Martin 24-hour service hotline at +45 70 200 201.

Protection from electric shock

- Disconnect the fixture from AC power before removing or installing the lamp, fuses, or any part, and when not in use.
- Always ground (earth) the fixture electrically.
- Use only a source of AC power that complies with local building and electrical codes and has both overload and ground-fault protection.
- Do not expose the fixture to rain or moisture.
- Refer all service to a Martin service technician.

Protection from UV radiation and lamp explosion

- Never operate the fixture with missing or damaged lenses and/or covers.
- When replacing the lamp, allow the fixture to cool for at least 30 minutes before opening the fixture or removing the lamp. Protect your hands and eyes with gloves and safety glasses.
- Do not stare directly into the light. Never look at an exposed lamp while it is lit.
- Replace the lamp if it becomes defective or worn out.

Protection from burns and fire

Warning *The exterior of the fixture can reach temperatures up to 100° C (212° F) at room temperature (25° C / 77° F). Allow the fixture to cool for 30 minutes before handling.*

- Never attempt to bypass the thermostatic switch or fuses. Always replace defective fuses with ones of the specified type and rating.
- Keep all combustible materials (for example fabric, wood, paper) at least 1 meters (39 inches) away from the Imager luminaire.
- Do not illuminate surfaces within 0.5 meters (20 inches) of the fixture.
- Provide a minimum clearance of 0.1 meters (4 inches) around fans and air vents.
- Never place filters or other materials over the lens.
-
- Do not modify the fixture or install other than genuine Martin parts.
- Do not operate the fixture if the ambient temperature (Ta) exceeds 40° C (104° F).

Protection from injury due to falls

- When suspending the fixture above ground level, verify that the structure can hold at least 10 times the weight of all installed devices.
- Verify that all external covers and rigging hardware are securely fastened.
- Block access below the work area whenever installing or removing the fixture.

Task checklist

√	Task	See
	Install Imager Base	<i>Imager Base user manual (P/N 35000128)</i>
	Install Imager J-Box and connect it to Imager Base	<i>Imager J-Box installation note (P/N 35000559)</i>
	Unpack and check all parts are included	page 9
	Install any optical options such as gobos, lens, filters, or a moving mirror.	page 41
	Choose a location and connect Imager to J-Box	page 10
	Create data link if using multiple fixtures	page 14
	Set Imager personalities using the control menus	page 17
When DMX control device is used		
	Connect DMX control device (if used)	page 36
	Using the control menus, set Imager profile option to “d1” or “d2” and set the DMX address	page 17 and page 37
	Program show, or use live control, with DMX control device	page 38
When stand-alone program is used (<i>not available in software Version 1</i>)		
	If optional IR is used:	
	<ul style="list-style-type: none"> • Ensure data link not terminated 	page 27
	<ul style="list-style-type: none"> • If this is the first fixture in the data link, install the optional IR receiver 	page 28
	<ul style="list-style-type: none"> • Set fixture IR address 	page 17
	If synchronous triggering of multiple fixtures is to be used, set triggering options (is the fixture receiving or sending scene change triggers?)	page 25
	Create stand-alone program, using:	
	<ul style="list-style-type: none"> • MP-2 Upload device, or the 	page 27
	<ul style="list-style-type: none"> • Optional IR remote control 	page 27
	Run stand alone program	page 31

Installation

This section describes in general terms how to mount the fixture and connect it to data and power. These procedures shall be performed by qualified professionals.

Note that all the measurements in the diagrams are expressed in millimeters (mm).

Note *This product must be installed in accordance with the applicable installation code by a person familiar with the construction and operation of this product and the hazards involved.*

Unpacking

The Imager comes with the following items:

- OSRAM HSD 250/80 lamp (installed)
- User manual
- Beacon gobo

Configuration overview

The Imager is designed to be attached to a ceiling mounted Imager J-Box.

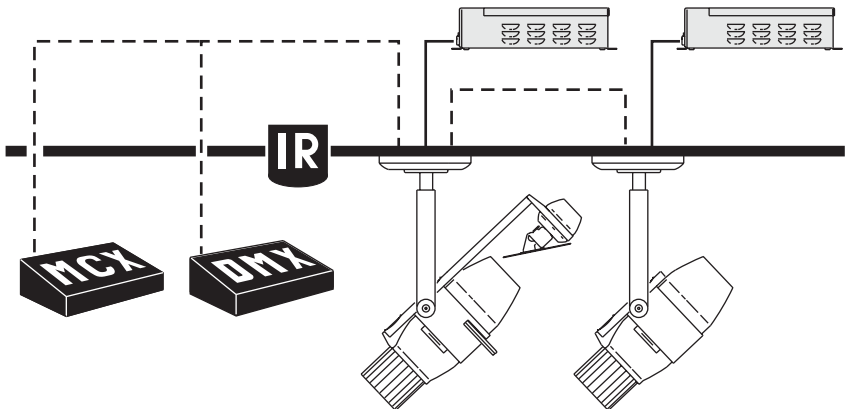

The J-Box is connected to a controlling device and power. An Imager Base supplies power to the Imager (via the J-Box).

The Imager is controlled via one of the following methods:

- DMX control device (such as a DMX controller or DMX recorder) which sends control signals in real-time
- Martin MC-X remote control to trigger a pre-programmed stand-alone show
- Martin Infrared receiver and remote control transmitter (to program and run stand-alone shows)

Via a CAT5 data network, a single Imager running a pre-programmed stand-alone show can trigger scene changes in other Imager luminaires (or in Martin Alien 02 or Martin MiniMac Maestro luminaires).

Mounting orientation and location

Do not locate the Imager luminaire in an unventilated space. Install the fixture in a location where it is:

- at least 0.5 meters (20 inches) away from the surface to be illuminated,
- at least 1 meter (40 inches) away from any combustible materials, and
- away from accidental public contact.

Attaching the Imager to a J-Box

All Imager luminaires must be mounted using an Imager J-Box. The J-Box is securely fastened to a ceiling surface using 4 units of 6mm mounting hardware appropriate to the mounting surface and appropriate to the combined weight of the J-Box and the Imager. For detailed instructions on mounting the J-Box refer to the *Martin Imager J-Box installation note* (P/N 35000559).

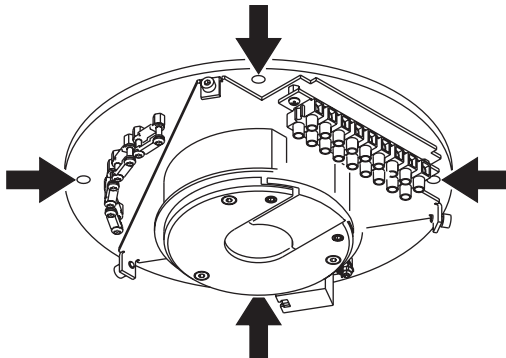

The following is an overview of the inside of the J-Box.

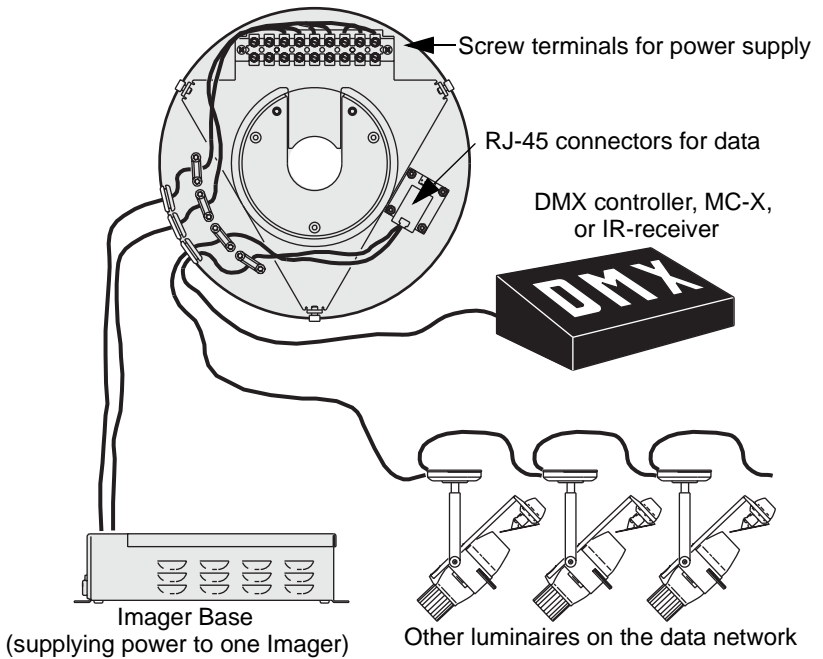

To attach the Imager to a J-Box:

- 1 Remove the J-Box cover by loosening the 3 Allen screws around the rim with a 3 mm Allen wrench.
- 2 Using the 3mm Allen wrench to loose the two locking screws, remove the slotted section of the J-Box (indicated in grey).

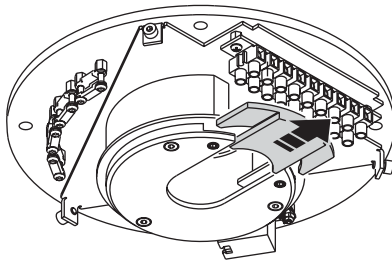

- 3 Pass the cables and mounting flange of the Imager through the center of the J-Box cover.

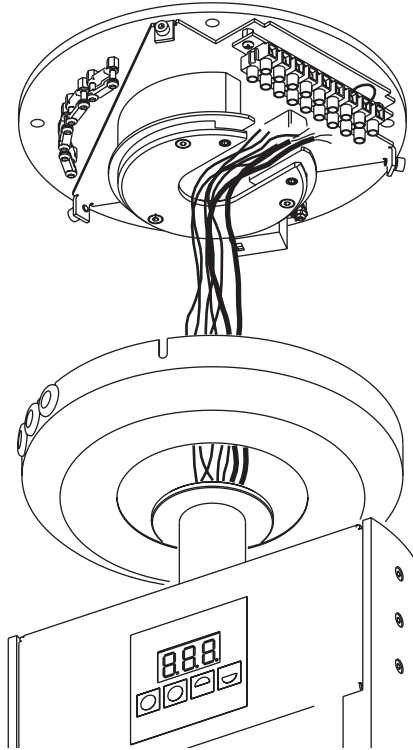

- 4 Slide the flange of the Imager into the slot on the J-Box. Replace the slotted section.
- 5 Move the Imager to the correct pan position and screw the locking screws in place using the 3 mm Allen wrench.

- 6 Locate the screw terminals and connect the colored cables from the Imager to the screw terminals on the J-Box.

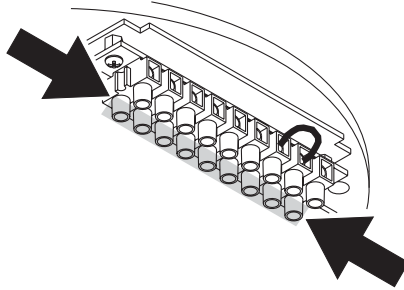
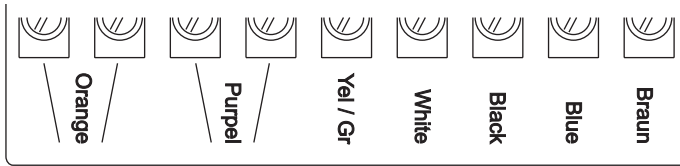

- 7 Connect the data cable from the Imager to the data connector in the J-Box. This can be found just behind the RJ-45 connectors.
- 8 Before closing the J-Box ensure that the power and data network cables are attached to the data terminals as described in “Data linking multiple fixtures” on page 14 and the Martin *Imager J-Box installation note* (P/N 35000559).
- 9 Loosen the three Allen screws on the arms of the J-Box and push the J-Box cover into place. Secure it with a 3mm Allen wrench.

Adjusting the projection angle

You can adjust the angle of the luminaire by making adjustments at the joints. To adjust a joint, use the 6 mm Allen wrench to loosen the joints on either side of the fixture. Adjust to the desired angle and re-tighten.

Power

Power is supplied from an Imager Base via the Imager J-Box. Refer to the Martin *Imager J-Box installation note* (P/N 35000559) and the Martin *Imager Base user manual* (35000128) for instructions on connecting power to the Imager.

This product must be mounted or supported independently of an outlet box. During installation of this equipment consult a qualified electrician to ensure correct branch circuit conductor.

Data linking multiple fixtures

You need to create a data link if you are going to be:

- Operating multiple Imagers in a synchronous way
- Controlling more than one fixture via a DMX control device
- Programming multiple fixtures via the IR receiver and IR remote control

Creating a data link

The data transmission rate (250 kbits/s) used by DMX512 requires the selection of a cable which does not significantly distort the signal or give rise to spurious signal reflections. Cables intended for use with audio systems (microphone cables), while having the convenience of flexibility, availability and relative low cost, are NOT suitable for use with DMX512 because of their high capacitance and incorrect characteristic impedance; at DMX512 data rates this will give rise to bit time distortion and signal reflections/overshoot.

Cabling systems shall provide a balanced, nominal 120 ohm terminated transmission line, and be made of cables with a characteristic impedance in the range 100-120 ohms.

Note: *Mixing cables of different impedances and other characteristics not isolated by buffers or other processing devices may affect system reliability.*

Always use solid or stranded shielded-twisted pair/foiled twisted pair (STP/FTP), 100 or 120 ohm cables that conform to ISO IEC 11801 category 5 or higher with RJ-45 connectors wired as follows

Pair	Wire #	Color	Function	DMX512 Pin
Pair 2	1	white / orange	data 1 +	DMX512 Pin 3
	2	orange	data 1 -	DMX512 Pin 2
Pair 3	3	white / green	data 2 +	DMX512 Pin 5
	4	green	data 2 -	DMX512 Pin 4
Pair 1	5	blue	Not assigned	
	6	white / blue	Not assigned	
Pair 4	7	white / brown	Signal Common (0 v)	DMX512 Pin 1
	8	brown	Signal Common (0 v)	DMX512 Pin 1
Shield			drain	

The minimum wire size is 0.2 mm (24 AWG) for runs up to 300 meters (1000 ft.) and 0.322 mm (26 AWG) for runs up 500 meters (1640 ft.). Your Martin dealer can supply the right cable in various lengths.

The RJ-45 sockets in the Imager J-Box are wired as follows - pins 7 & 8 to ground, pin 2 to signal - (cold), and pin 1 to signal + (hot).

Creating the data link

- 1 Connect one of the RJ-45 connectors in the J-Box to one of the RJ-45 connectors in the next J-Box.
- 2 Continue connecting fixtures output to input. Up to 32 devices may be connected on a serial link.
- 3 If you are not using the infrared remote control and receiver, terminate the link by inserting an RJ-45 termination plug (for example an 100 ohm RJ-45 ISDN terminator) into the DMX data output of the last J-Box.

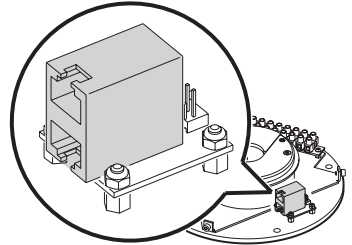

Warning *If you are using Stand-Alone programs (see “Stand-Alone programming overview” on page 24) on multiple fixtures on a data link and you experience random “flicker” or other unexplained control problems, insert a female termination plug (P/N 91613018) into the IN socket of the first fixture.*

General operation

When the Imager is connected to power it will reset. The text rSt will appear in the control panel display while this occurs. When the reset is completed the fixture address will appear in the control panel display.

External control

The Imager can be controlled with DMX signals from a DMX control device such as a DMX recorder or DMX controller. This is described in “Section 3. DMX control” on page 35.

Stand-Alone programming

Important ***Stand-alone programming and infrared control are not available in version 1 of the Imager firmware and are planned for a future update that will be available for download from the support pages at <http://www.martinarchitectural.com>, or from your Martin dealer.***

Using stand-alone programming, there are two ways of programming and storing a show in the fixture itself:

- Via an MP-2 Uploader, or
- Using the optional IR remote control (that communicates with the optional IR receiver mounted on the first fixture in a data link). This method is popular for installations of up to 10 fixtures because access to the various functions is faster, and because multiple fixtures can be simultaneously selected and programmed from a single IR remote control unit (this potentially time-saving method is known as IR Stand-Alone). If you have any MiniMac Maestro or Alien 02 luminaires installed on the data link you can also use this method to program them.

Stand-Alone programming is described in “Section 2. Stand-Alone operation” on page 23.

Control panel

The control panel is used to set the fixture address and other settings. It can also be used to operate the fixture in a limited way manually for testing and service purposes.

The control panel will (by default in the personality settings) be deactivated and switch off after 2 minutes if no buttons are pressed. When inactive error messages will still be displayed (provided that this has not been deactivated in the fixture personality settings). To reactivate the display press one of the buttons for two seconds and release it.

Navigating the control menu

The control panel displays the fixture address at the top of the menu. If there are any error messages these are displayed as well. To get to the top of the menu, press [menu] repeatedly. From the top, press [menu] to enter the main menu. Press [up] or [down] to scroll through menus and press [enter] to view submenus. To activate a setting or function, press [enter]. To return to the previous menu or to escape without making a selection, press [menu].



Inverting the display

Press [up] and [down] at the same time.

Menus

The control panel menu is detailed in “Control menu structure” on page 64. They are described at a high level here.

Address menu (Adr)

Depending on the setting in the Profile menu (see “Profile menu (PRO)”), the Address menu is used to set either a:

- DMX control address (1-512), where a fixture will be controlled by DMX signals from a DMX control device.
- IR fixture ID number (0-9), where a fixture will be programmed using an IR remote control.

Profile menu (PRO)

The Profile menu contains options where you can specify if the fixture is:

- Using the IR remote control system and has the IR receiver installed (option rCS), or
- Using the IR remote control system and does not have the IR receiver installed (option rCr), or
- Not using the IR remote system (options d1 or d2). Always specify one of these when the optional IR remote control system is not in use:
 - *DMX mode 1* uses 9 channels and does not allow fine adjustment of movement and effects.
 - *DMX mode 2*, which is the default, uses 12 channels and allows fine adjustment of movement and effects.

Stand-alone menu (SA)

The Stand-Alone menu commands can be used to execute scenes in Stand-Alone mode. See “Programming using the optional infrared remote control” on page 27 for further information.

Adjustment menu (ADJ)

The Adjustment menu (Adj) provides manual control for service use.

Personality menu (Per)

The Personality menu sets some basic characteristics, or the personality, that the fixture has.

Lamp-off and reset

These options enable you to disable the lamp-off and reset commands that are used on DMX channel 1. This might be useful if you are using a DMX control device with your Imager, because it reduces the chance of accidentally selecting lamp-off on channel 1 during a show. The default is that these commands are enabled.

Note that the lamp must be allowed to cool for at least 6 minutes after turning it off before it can be re-struck. A 6-minute hot-restrike delay is programmed into the Imager software from the time that the light is extinguished, or the power is switched off, to ensure that this occurs. If you attempt to strike the lamp and do not succeed the fixture will reattempt to strike itself after 6 minutes, unless you issue the lamp off command. If the fixture fails these two attempts to strike, the lamp will be assumed to be defective and the LE (lamp error) message will appear.

Automatic lamp-on

When enabled, this will strike the lamp automatically within 90 seconds of applying power to the fixture. By default this is set to `Off`.

Display

Turn off the display 2 minutes after the last key press or leave it on. This setting will be overridden by error and warning messages. By default this option is on.

Store remote status (SRS)

This SRS option is only relevant when you are using the optional infrared remote control and receiver (*not presently available*). If SRS is:

- On (default), and you start or stop the programmed show using the IR remote control, the fixture will additionally be set to automatically start or stop the show next time it is powered on.
- Off, the IR remote control has no influence over the automatic starting of a programmed show at power-on. This is controlled by the `SA / Run` menu (see “Starting show playback” on page 31).

Enable lamp off control from an MC-X

When using an MC-X control device to select and run scenes, button 7 can be used to turn the lamp off.

The lamp must be allowed to cool for at least 6 minutes after turning it off before it can be re-struck. A 6-minute hot-restrike delay is programmed into the Imager software from the time that the light is extinguished, or the power is switched off, to ensure that this occurs. If you attempt to strike the lamp and do not succeed the fixture will reattempt to strike itself after 6 minutes, unless you issue the lamp off command. If the fixture fails these two attempts to strike, the lamp will be assumed to be defective and the LE (lamp error) message will appear.

Errors and warnings message toggle

This enables error and warning messages to be suppressed. This enables, for example, the continued programming of a fixture that has a non-critical error. The default setting is On, which means that errors messages will not be suppressed and can be seen, when active, at the top level of the control menu structure.

Lamp Temperature fan regulation

Allows the lamp fan in a Imager to be automatically adjusted based on the temperature.

Gobo Temperature fan regulation

Allows the gobo fan in a Imager to be automatically adjusted based on the temperature.

Temperature warnings enabled

Enables temperature warnings to appear in the display and shut down the lamp.

Lamp hour warning

Using this menu you can enable or disable lamp life warnings and set the number of hours of expected life that apply to the lamp type installed. A counter operates that can be read and reset in the `Inf` menu. When the resettable lamp hour counter reaches:

- 100 hours less than the predefined lamp hour warning level, the display will start blinking 'Lhu' in the display. At this point you should change the lamp to avoid the risk of lamp explosion.
- The predefined lamp hour warning level, the lamp shuts off and can not be turned on again before the counter is reset, or the predefined lamp hour warning level has been redefined.

We recommend that you activate the Lamp Hour Warning function on the Imager and that you set the expected number of hours of life the lamp has. Remember to also reset the lamp hour counter using the Information menu.

Restore factory defaults

Restores factory default settings in the Personality menu.

Reset all counters

Resets all resettable counters (these are found under the Information menu).

Information menu (INF)

The Imager provides readouts to track usage, temperature, maintenance intervals, lamp life, and software version. Values from 1000 to 9999 are automatically scrolled and counters roll over to 0 when they reach 10,000.

Displaying or resetting a counter

Scroll to `Inf` in the main menu, press [enter] and scroll to the desired readout. Press [enter] and scroll to the desired option. Press [enter] to display the information.

Note that the resettable counters (rES) in the Inf menu can be set to zero by pressing and holding [up] for approximately 5 seconds, until the readout displays 0.

Utility menu (Utl)

The Utility Menu is used to set the fixture into Boot Upload Mode. See “Firmware updates” on page 56.

Test menu (TST)

This is used by Martin service personal to test the printed circuit board.

SECTION 2. STAND-ALONE OPERATION

Stand-Alone programming overview

Important *Stand-alone programming and infrared control are not available in version 1 of the Imager firmware and are planned for a future update that will be available for download from the support pages at <http://www.martinarchitectural.com>, or from your Martin dealer.*

In stand-alone mode, individual Imagers can be programmed to run a show of up to 20 scenes without an external controller. This can be done using the control panel or the optional IR remote control system.

The Imager will run its show in a continuous loop.

Multiple Imagers on a data link all have their own shows individually programmed, but can have scenes synchronously triggered by a one fixture on the data link.

About scene timing

Each scene has a dynamic part - the fade - during which effects move to the scene's programmed positions, and a static part - the wait - where effects do not change.

The duration of the fade and wait is programmed individually for each scene. The fade time may be 0 - 120 seconds; the wait time may be 0 - 600 seconds. The total time

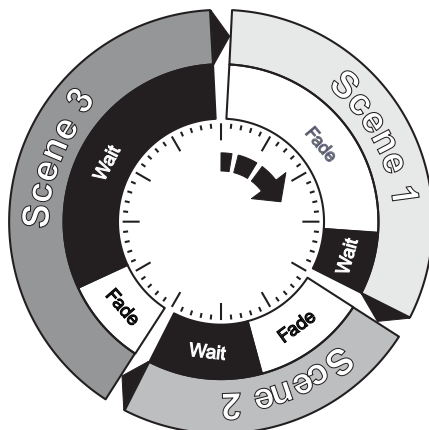

it takes a scene to execute is the sum of the fade and wait times.

When operating multiple fixtures synchronously, the wait time is determined by the fixture that issues scene change commands. It does this when it reaches the end of each scene wait time. Every other fixture fades and waits at its own rate and then remains in the “wait state” until receiving a start scene xx command. When programming in synchronous triggering situations, keep in mind that in order to keep things as simple as possible there are two rules of thumb that will make life much easier; try to ensure that:

- 1 Every fixture has the same number of scenes.
- 2 Respective scene times are a few seconds longer on the fixture that issues triggering commands.

The rules used in the algorithm are detailed in “Synchronous triggering during Stand-Alone operation” on page 33.

Synchronizing scene changes for multiple Imagers

In situations where you are running multiple Imagers on a data link it is possible to synchronize scene changes. Read this section if this applies in your case.

It is important to note that each individual fixture must be programmed with a show and that the only commands that are passed are scene change commands. No data about the look of the scene is passed between fixtures.

Setting synchronized triggering options

- 1 Scroll to *SA* in the top level of the menus on the control panel and press [enter].
- 2 Scroll to *SAE* and press [enter].
- 3 Select:
 - Sin** If the fixture will operate in isolation (with no synchronous triggering). This is the factory default setting.
 - Snd** If the fixture will send scene triggering signals to the other Imagers on the data link.
 - Syn** If the fixture should “listen” for scene trigger signals on the data link.
- 4 Press [enter].

Programming methods

The Imager provides two stand-alone programming methods; using the:

- MP-2 Upload device. See the *MP-2 user manual* for further information, or an
- Optional infrared remote control and infrared receiver. Using this method you can simultaneously select and program up to ten Imager fixtures on a single data link using a handheld remote. This method can save time programming individual fixtures. See “Programming using the optional infrared remote control” on page 27 for further information.

Programming using the optional infrared remote control

Important *Stand-alone programming and infrared control are not available in version 1 of the Imager firmware and are planned for a future update that will be available for download from the support pages at <http://www.martinarchitectural.com>, or from your Martin dealer.*

Programming can be performed using an optional infrared transmitter and receiver system that are orderable from your Martin dealer. Infrared programming can be performed for a single fixture, or up to 10 fixtures on a data link.

The optional IR remote control device can be used to program 20 scenes that make up a show. Note that:

- Every fixture can have up to 20 on-board scenes with individual fade & wait times.
- Scenes are numbered from 0 to 19.
- A scene contains a fade-section where the fixture shifts to the scene, followed by a wait-section where the scene effect is shown.
- Programming using the IR remote control is easiest when the display on the Imager control panel can be seen.

You can also program any MiniMAC Maestro fixtures on the same data link. Refer to the *MiniMAC Maestro user manual* for further information.

Note that it is always possible to perform stand-alone programming using an MP-2 uploading device (refer to the *MP-2 user manual* for more information).

Before you begin programming

If you are running multiple fixtures, ensure that:

- You have established a data link (see “Data linking multiple fixtures” on page 14) and that the IR-receiver is connected to the data link (you may need an XLR-RJ-45 converter to do this) and installed in a line-of-site location.
- There is *no* termination plug in the last fixture in the data link.

Ensure the stand-alone program is not running

To stop the current stand-alone program running:

- 1 Press [menu] to return to the top level of the menu.
- 2 Scroll to *SA* in the top level of the menus on the control panel and press [enter].
- 3 Scroll to *run* and press [enter].
- 4 Scroll to *Off* and press [enter].
- 5 Press [menu] to return to the top level of the menu.

Enabling infrared programming

Perform the following steps in this order:

- 1 Only the first fixture on the data link can have an IR receiver. Insert the receiver module into the serial data In socket. Position the sensor arm as desired but avoid turning it more than necessary.
- 2 From the top level of the menu, scroll to *PRO*, press [enter].
- 3 If this fixture:
 - Does not have the IR receiver installed, scroll to *rCr*. Press [enter].
 - Has the IR receiver installed, scroll to *rCS*. Press [enter].
- 4 Press [menu] to return to the top level of the menu.
- 5 Select *Adr* and press [enter]. Select an IR fixture address from 0 to 9 and press [enter]. Note that if you have multiple fixtures that will run the same stand-alone scenes it might be a good idea for them to share the same IR fixture address. This will save time when programming, as they will all receive and process the scene programming instructions simultaneously.
- 6 Press [menu] to return to the top level of the menu.
- 7 Stand 2 meters (6 ft.) away from the fixture, point the remote control at the receiver, and press the lamp power button. If there is no response, try the ID button. If there is still no response, reverse the sensor head by rotating the sensor arm 180° and folding it over.

Remote control commands

Important! *The luminaire will acknowledge the receipt each valid IR command with a slight change in intensity.*

Fixture selection

Each fixture must be assigned an address from 0 - 9 during setup so that it can be individually controlled with the remote control. Note that fixtures can share an address if they are to have the same program.

To select a fixture, press ID and enter its address using the number keys. Multiple fixtures may be selected by entering more than one address. For example, pressing [ID] [1] [2] [3] selects fixtures 1, 2, and 3.

Lamp power

The lamp power button toggles lamp power on and off on selected fixtures. The button must be held for 5 seconds to turn lamp power off. Note: Lamps cannot be turned off during scene execution and a discharge lamp must cool for several minutes after being turned off before it can be turned back on.

The lamp must be allowed to cool for at least 6 minutes after it is switched off before it can be re-struck. A 6-minute hot-restrike delay is programmed into the Imager software from the time that the light is extinguished, or the power is switched off, to ensure that this occurs. If you attempt to strike the lamp and do not succeed the fixture will reattempt to strike itself after 6 minutes, unless you issue the lamp off command. If the fixture fails these two attempts to strike, the lamp will be assumed to be defective and the LE (lamp error) message will appear.

Scene timing

Fade and wait times are set by pressing the scene timing buttons and entering the desired time in seconds using the number keys.

Scene Selection

Scenes are created, selected, saved, and deleted using the six scene keys. The current scene is displayed on the fixture display after the letter “1” during editing and after the letter “P” during execution.

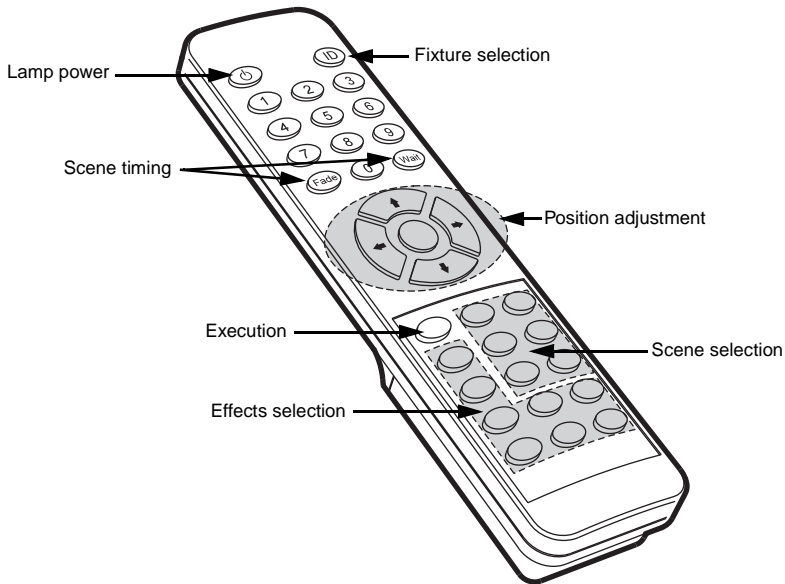

- **Prev** (previous scene) scrolls backwards through scenes on selected fixtures.
- **Next** (next scene) scrolls forwards through scenes on selected fixtures.
- **Store** (store scene) saves effect and timing settings to the current scene.
- **Delete** (delete scene) removes the current scene from memory. Scenes above the deleted scene are renumbered.
- **INS** (insert scene) creates and saves a new scene before the current scene, which moves up a number.
- **ADD** (add scene) creates a new scene at the end of the sequence with the settings that are active when the scene is created.

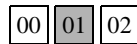

Store saves settings in the current scene.

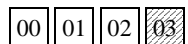

Add saves settings in a new scene at the end of the sequence.

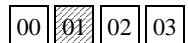

Insert saves settings in a new scene before the current scene.

Effects Adjustment

The look of a scene is programmed by first selecting an option with the effect selection buttons and then adjusting the option with the position adjustment buttons. When two effects are assigned to a selection button, the up/down arrows control one effect and the left/right arrows control the other effect. If there is only one effect, the up/down arrows usually provide course adjustment and the left/right arrows usually provide fine adjustment. The middle button returns effects to a default position.

Stand-Alone show playback

Important *Stand-alone programming and infrared control are not available in version 1 of the Imager firmware and are planned for a future update that will be available for download from the support pages at <http://www.martinarchitectural.com>, or from your Martin dealer.*

Starting show playback

- 1 From the top level of the control menu, scroll to SA and press [enter].
- 2 Scroll to SA in the top level of the menus on the control panel and press [enter].
- 3 Scroll to run and press [enter].
- 4 Scroll to On and press [enter].

When the show starts to run the current scene number will appear in the control panel display (unless the Per/dIS menu has been set to OFF, in which case the display will switch off two minutes after the last key is pressed).

Important! *Execution of the pre-programmed scenes in a loop will automatically resume when the fixture is powered-on if stand-alone is enabled and the automatic lamp-on (Per/ALO) function is enabled (see “Automatic lamp-on” on page 19).*

Show Execution with the IR remote control

The Run/Stop button on the IR remote control toggles scene execution on/off on fixtures that are selected (see “Fixture selection” on page 29). Scenes execute in a continuous ascending loop.

All remote control functions except Run/Stop are disabled during show execution.

If the Store Remote Status option (see “Store remote status (SRS)” on page 19) is enabled, then the Run/Stop button will also toggle the `SA / run` option to `OFF` or `On`, so that next time the fixture is powered on it will automatically start (or not start) the Stand-Alone show.

Scene execution Using the optional MC-X

The MC-X is an optional remote control unit that is available from Martin. Once the remote controller is connected, 7 scenes can be conveniently called up on the MC-X's buttons.

To enable control:

- 1 Connect the MC-X controller to the Imager's data network via an XLR-to-RJ-45 adaptor. If multiple Imagers are connected, plug the controller into the first fixture in the link.
- 2 On each fixture, select `SA / run / OFF` and press [enter]. Press [menu] to exit the `SA` menu.
- 3 On each fixture, select `PrO / dl` and press [enter]. Press [menu] to exit the `PrO` menu.
- 4 To trigger scenes 00-06, press the numbered preset buttons on the MC-X.
- 5 To have each fixture run its own routine, press [Auto].

Using the `Per / nnO` menu it is possible to set button 7 on the MC-X to control the lamp off function. See “Control menu structure” on page 64.

DMX controller override during Stand-Alone show playback

If an Imager is connected to a DMX controller and receives DMX signals during show playback, the Stand-Alone show will stop running and the fixture will respond to the DMX controller. DMX signals always have priority over the running of a Stand-Alone show.

Synchronous triggering during Stand-Alone operation

Important *Stand-alone programming and infrared control are not available in version 1 of the Imager firmware and are planned for a future update that will be available for download from the support pages at <http://www.martinarchitectural.com>, or from your Martin dealer.*

Note *This chapter details the rules that are used in Stand-Alone synchronous triggering. It is not necessary to read this chapter unless you require help with problem diagnosis or unless you otherwise need a detailed understanding of the algorithm used for synchronous triggering.*

The rules are as follows:

- 1 Every fixture can have up to 20 on-board scenes with individual fade and wait times.
- 2 Scenes are numbered from 0 to 19.
- 3 A scene contains a fade-section, followed by a wait-section.
- 4 When running "synchronous triggering" one Imager issues commands to the other Imagers to "go to scene xx", where xx is the scene number that master will execute next.
- 5 If a slave has fewer scenes than the master, it will derive which scene to go to by dividing the number of the scene it has been commanded to go to (scene 5, for example) by the total number of scenes that the slave fixture has (4, for example) in whole numbers (no decimal places). In this example 5 divided by 4 results in 1, with 1 remainder. This remainder will be the number of the scene that the slave fixture starts - scene 1. Generally though, when a Slave fixture reaches its own last scene before the Master fixture, a "go to scene x" message will result in the first scene being played.

- 6 If a slave has more scenes than the master calls, the last scenes in the slave will never be executed, as is the case with scene S4 in the following example.

F=fade, W=wait Timeline =>

Programmed in Master	M0	M1	M2	M3	
	F W	F W	F W	F W	
Programmed in Slave	S0	S1	S2	S3	S4
	F W	F W	F W	F W	F W
Result	M0	M1	M2	M3	
	F W	F W	F W	F W	
	S0	S1	S2	S3	
	F W	F W	F W	F W	

- 7 A slave fixture will not listen for the next message from the master fixture before it has finished its current scene. This may result in a slave skipping a scene if slave has a longer scene time than master. Note that in the following example the scenes in the Slave run out of their programmed sequence because scenes 0 and 2 on the Slave are longer than the corresponding scenes on the Master.

M=master, S=slave

F=fade, W=wait Time >

Programmed	M0	M1	M2		
	F W	F W	F W		
Slave	S0	S1	S2		
	F W	F W	F W		
Result	M0	M1	M2	M0	M1
	F W	F W	F W	F W	F W
Slave	S0	S2	S1		
	F W	F W	F W	F W

SECTION 3. DMX CONTROL

DMX Controller operation

The Imager may be programmed and operated with any lighting control device that is compatible with the USITT DMX standard. This section describes how to operate the system with a controller.

See the appropriate section for specific control values for your Imager model:

- “Imager DMX-Gobo Wheel” on page 69.
- “Imager DMX-Gobo Wheel with moving-mirror fitted” on page 70.
- “Imager DMX-Gobo” on page 72.
- “Imager DMX-Gobo with moving-mirror fitted” on page 73.

Connecting a DMX control device

Connect a data cable from the Imager J-Box to the control device’s data output. If the control device does not have an RJ-45 socket then you may need to purchase or wire an XLR-to-RJ45 converter. For wiring information see “Creating a data link” on page 14.

Set the appropriate DMX mode

There are two DMX modes:

- *DMX mode 1* uses 9 channels and does not allow fine adjustment of movement and effects.
- *DMX mode 2*, which is the default, uses 12 channels and allows fine adjustment of movement and effects.

The mode that is used is specified using the Profile menu in the control panel (see “Control menu structure” on page 64).

Control address selection

The Imager requires 9-12 DMX control channels (depending on the DMX mode that is selected). The DMX address, also known as the start channel, is the first control channel used. It is a logical address to which control instructions are sent. In this way a controller, can send instructions to a fixture, or fixtures, at a particular address. For example when using nine channels of control data (DMX mode 1), the Imager reads the data on the start channel (DMX address) and the next eight channels. If the DMX address is set to 100, the Imager uses channels 100, 101, 102, 103, 104, 105, 106, 107 and 108.

Be sure to allow adequate channels when setting the control address. If control channels for one fixture overlap control channels for another fixture, then one of the fixtures will receive the wrong commands. Two Imagers may share the same address if they are to respond identically. They will receive the same commands and individual control will be impossible.

The default factory set control address is '1'.

Setting the control address

- 1 Scroll to **P r O** in the top level of the menus on the control panel and press [enter].
- 2 Select **d1** or **d2** to enable DMX control. Press [enter].
- 3 Press [menu] to return to the top level of the menu.
- 4 Scroll to **A d r** in the top level of the menus on the control panel and press [enter]. The current address is displayed.
- 5 Scroll to the address that is assigned to the fixture on the controller. Press [enter] to activate the address setting.

Disable Stand-Alone operation (if required)

DMX control always overrides any Stand-Alone show that is running, but if Stand-Alone mode is enabled and no DMX signal is received, the Imager will attempt to run any show in its memory. To prevent this:

- 1 Press [menu] to return to the top level of the menu.
- 2 Scroll to **S A** in the top level of the menus on the control panel and press [enter].

- 3 Scroll to `run` and press [enter].
- 4 Scroll to `Off` and press [enter].

Lamp control

Important ***Avoid striking several lamps at once!***

The lamp can be turned on and off from the controller using the lamp-on and lamp-off commands on channel 1. To prevent accidental lamp-off commands, lamp off can be partially disabled from the using the `Per / LOF` menu on the control panel (see “Control menu structure” on page 64). If the DMX Lamp-off personality is off, the lamp-off command on channel 1 executes only on an:

- Imager DMX Gobo Wheel, if gobo position 4 is selected (either in indexed or continuous rotation) and the focus is set to the near position.
- Imager DMX Gobo, if DMX-channel 3 is set to a value of 60-79 or 140-159, and the focus is set to the near position.

Strike lamps one at a time at 5 second intervals. Striking many lamps at once may cause a voltage drop large enough to prevent lamps from striking, damage electronics, and trip circuit breakers. To have the lamp strike automatically at power-up, set the Automatic Lamp-on personality to on (see “Personality menu (Per)” on page 18).

The lamp must be allowed to cool for at least 6 minutes after turning it off before it can be re-struck. A 6-minute hot-restrike delay is programmed into the Imager software from the time that the light is extinguished, or the power is switched off, to ensure that this occurs. If you attempt to strike the lamp and do not succeed the fixture will reattempt to strike itself after 6 minutes, unless you issue the lamp off command. If the fixture fails these two attempts to strike, the lamp will be assumed to be defective and the LE (lamp error) message will appear.

Effects

The mechanical effects reset to their home positions when the fixture is powered on. Effects can also be reset from the controller on channel 1. If the DMX Reset personality is off, the reset command on channel 1 will only execute on an

- Imager DMX Gobo Wheel only if gobo position 4 is selected (either in indexed or continuous rotation) and the focus is set to the near position.

- Imager DMX Gobo only if DMX-channel 3 is set to a value of 60-79 or 140-159, and the focus is set to the near position.

Note that use of DMX mode 2 provides for fine positioning control of effects. See “Set the appropriate DMX mode” on page 36.

Intensity

The fixture provides smooth, high resolution, full-range intensity control on channel 2.

Focus

The fixture provides focus control from 2 meters to infinity on channel 5 (DMX mode 1) or 6 (DMX mode 2).

Gobo effects

Gobo selection (for the Imager DMX Gobo Wheel), rotation and indexing control are available on channels 3 and 4 (DMX mode 1) or 3 to 5 (DMX mode 2).

Moving mirror control

Pan, tilt, and speed control of the optional moving mirror is available on channels 6 to 8 (DMX mode 1) or 7 to 11 (DMX mode 2).

The speed at which the mirror moves from one position to another, can be controlled in two ways known as tracking control and vector control. You may switch between tracking and vector control, but you cannot use both at the same time.

Tracking control is enabled by setting channel 8 (in DMX mode 1) or 11 (in DMX mode 2), to a decimal value from 0 to 2. Fades are then programmed using the controller’s cross-faders. The Imager has a digital filter algorithm that averages several updates to ensure smooth movement.

Vector control provides a way to program fades on controllers without cross-faders and may provide smoother fades than tracking control with some controllers, particularly on very slow fades. A vector speed is programmed by setting channel 8 (in DMX mode 1) or 11 (in DMX mode 2) to a decimal value from 3 (fastest) to 251 (slowest). When using vector control, the controller cross-fade time, if available, must be 0.

Blackout while moving

Image projection can be blacked out while the mirror moves at maximum speed from one position to the other by setting channel 8 (in DMX mode 1) or 11 (in DMX mode 2) to a decimal value from 252 to 255.

SECTION 4. OPTICS AND PROJECTION ACCESSORIES

Gobos

The:

- Imager DMX Gobo Wheel accepts up to four metal or glass gobos
- Imager DMX Gobo accepts a single metal or glass gobo

The gobos must be size D with an outside diameter of 53.3 mm (2.10 in.) and a maximum image diameter of 40 mm (1.57 in.).

The images can be rotated in both directions or set in an indexed position.

A single Imager promotion gobo is factory installed.

Image projection size

To calculate the size of a projected image using a gobo of a given size, the formula is

$$\text{projected image size} = \frac{\text{gobo image size} \times \text{projected distance}}{\text{focal length}}$$

To calculate the gobo image size required to achieve a projected image size, the formula is

$$\text{gobo image size} = \frac{\text{projected size} \times \text{focal length}}{\text{projected distance}}$$

The focal length of the Imager will be one of the following:

- 150 mm (5.9 in.) for the optional 15° lens
- 100 mm (3.9 in.) for the standard 23° lens
- 70 mm (2.75 in.) for the optional 32° lens

Custom gobos

For optimum performance, custom glass gobos for the Imager should be made with the text, logo, and similar artwork reversed on the coated side (unless the moving mirror accessory is fitted as this will invert the gobo image that is projected).

Gobo orientation

The following illustrations show the correct orientation for different gobo types. When in doubt, install gobos with the more reflective side towards the lamp.

Coated Glass Gobos

Coated side towards lamp

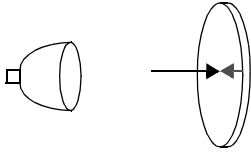

When an object is held up to the coated side there is no space between the object and its reflection. The back edge of the gobo cannot be seen when looking through the coated side.

Uncoated side towards surface

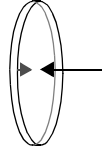

When an object is held up to the uncoated side there is a space between the object and its reflection. The back edge of the gobo can be seen when looking through the uncoated side.

Textured Glass Gobos

Smooth side towards lamp

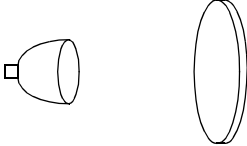

Textured side towards surface



Reflective side towards lamp

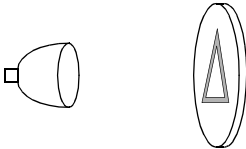

Black side towards surface



Metal Gobos

Reversed image towards lamp

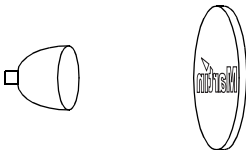

True image towards surface



Image/text Gobos

Replacing a gobo

Imager DMX Gobo

- 1 Disconnect the fixture from AC power and allow it to cool for 15 minutes.
- 2 Remove the top cover of the fixture using a 2.5 mm Allen wrench.

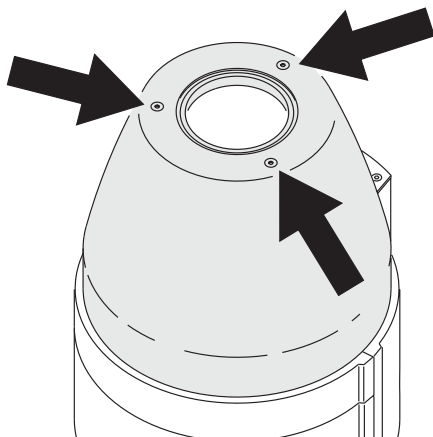

- 3 Unscrew the thumb screw holding the gobo plate in place.

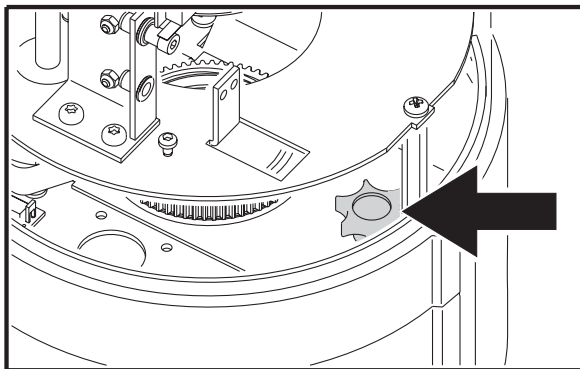

- 4 Remove the gobo plate from the fixture.

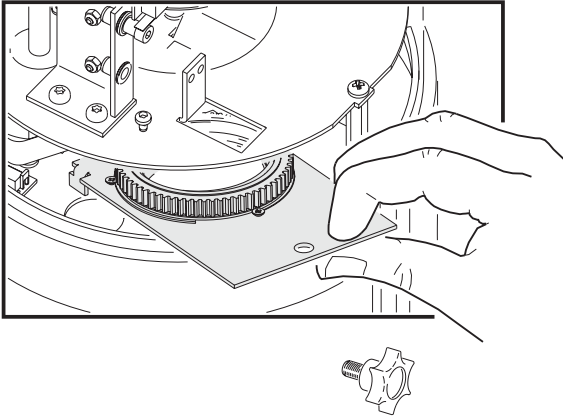

- 5 Squeeze the ends of the retention spring (inside the gobo holder) together and remove. Push the existing gobo (if installed) out from the back and remove.
- 6 Orient the gobo as shown in “Custom gobos” on page 42 and insert the replacement gobo into the holder. Secure the gobo with the retention spring.
- 7 Replace the gobo plate, screw it into place, and replace the fixture cover.
- 8 Applying power.

Imager DMX Gobo Wheel

- 1 Disconnect the fixture from AC power and allow it to cool for 5 minutes.
- 2 Rotate the gobo wheel to a position that allows you to access the gobo.

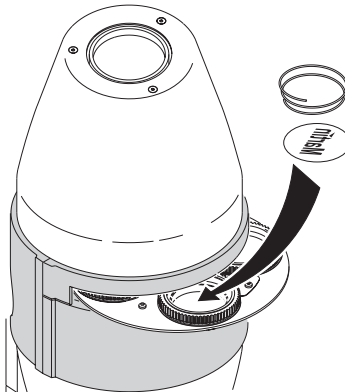

- 3 Using a small screwdriver if necessary, squeeze the ends of the retention spring (inside the gobo holder) together and remove the existing gobo (if installed) and spring.
- 4 Orient the gobo as shown in “Custom gobos” on page 42 and insert the replacement gobo into the holder. Secure the gobo with the retention spring.
- 5 Apply power.

Filters

A Slide Projection Kit, or hexagonal color/heat filter can be installed in the Imager. The holder slides out of the side of the fixture and is held in place by a magnet.

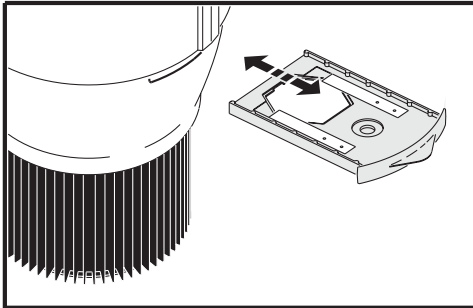

The following filters are available (at the time of printing) from your Martin dealer.

Color temperature correction filter 5500-3400K	P/N 46402019
Blue 101 color filter	P/N 46402001
Blue 104 color filter	P/N 46402017
Blue 107 color filter	P/N 46402014
Blue 108 color filter	P/N 46402015
Blue 111 color filter	P/N 46402013
1/2 Minus Green color filter	P/N 46402024
Green 201 color filter	P/N 46402022
Green 204 color filter	P/N 46402005
Green 205 color filter	P/N 46402003
Green 206 color filter	P/N 46402007
Yellow 603 color filter	P/N 46402004
Orange 302 color filter	P/N 46402010
Orange 306M color filter	P/N 46402009
Red 304 color filter	P/N 46402002
Red 308 color filter	P/N 46402011
Magenta 507 color filter	P/N 46402012
Pink 312 color filter	P/N 46402006
Purple 502 color filter	P/N 46402018

The number next to each color filter is an OCLI (Optical Coating Laboratory, Inc.) reference number.

Lens options

The following lenses are available for the Imager luminaire:

- 23° lens (fitted as standard)
- 15° lens (a screw on attachment)
- 32° lens (a screw on attachment)

Changing the lens

To change the lens:

- 1 Disconnect the fixture from AC power and allow it to cool for 30 minutes.
- 2 Remove the cover of the fixture using a 2.5 mm Allen wrench.

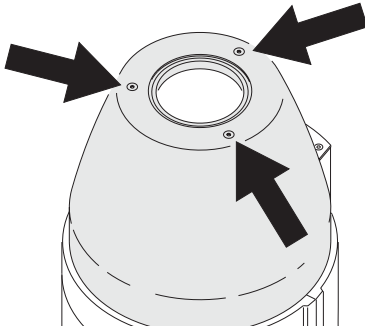

- 3 Rotate the spindle to move the standard lens as far away from the lamp as possible.

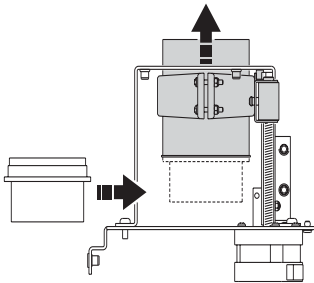

- 4 Slide the optional lens in under the standard lens, and screw it to the thread on the standard lens.

- 5 Adjust the position of the pin that functions as the mechanical stop to the appropriate position.

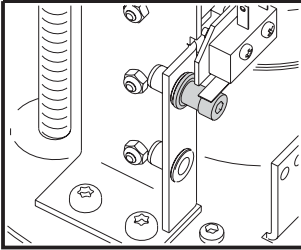

15° lens position

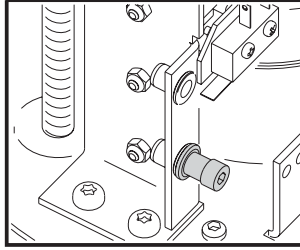

23° standard position

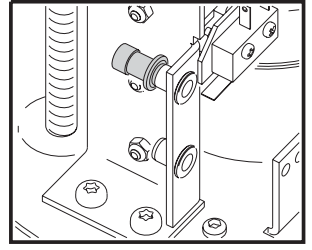

32° lens position

Note that for the 32 degree lens the pin is removed and inserted from the other side of the plate.

- 6 Replace the fixture cover and apply power.

Moving mirror

The optional moving mirror, enables programmable movement, useful for moving logos or gliding messages. It provides smooth movement in a range of 235° of pan by 65° of tilt.

To install the moving mirror:

- 7 Disconnect the fixture from AC power and allow it to cool for 30 minutes.
- 8 Remove the cover of the fixture using a 2.5 mm Allen wrench.

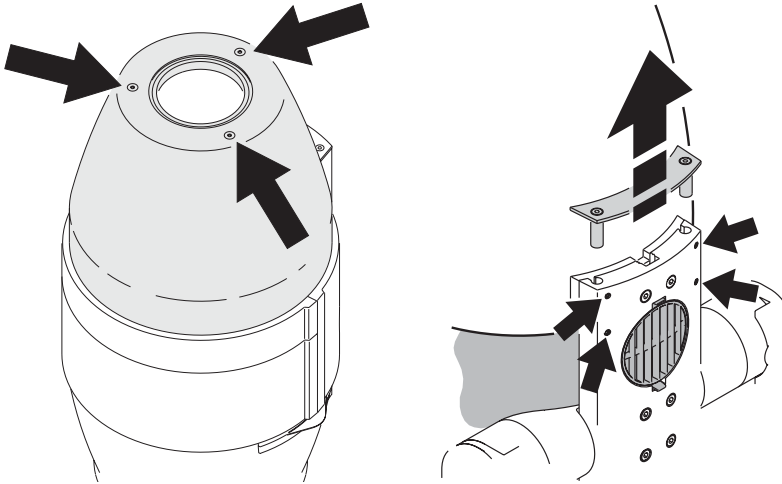

- 9 Using a 2mm Allen wrench, loosen the 4 recessed Allen screws on the spine of the fixture and remove the cover plate.

10 Slide the struts on the moving mirror into the Imager.

11 Once in position lock the mirror into place by tightening the 4 recessed Allen screws on the spine of the fixture.

12 Attached the cable to the connector in the Imager.

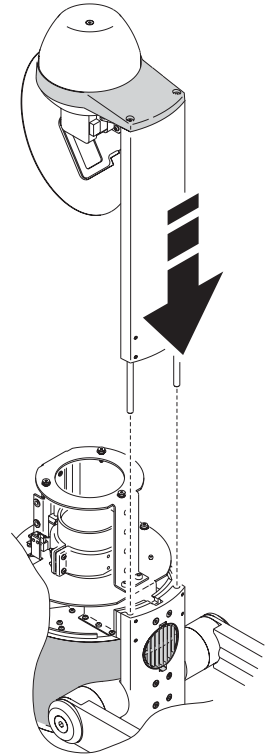
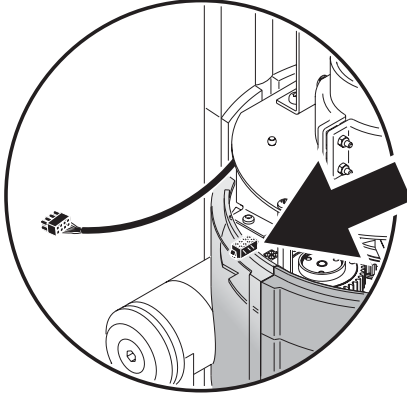

13 Place the cable so that it stays out of the optical path.

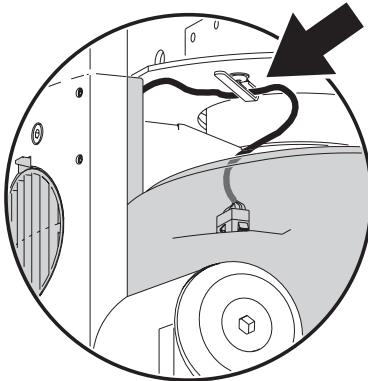

14 Replace the fixture cover and apply power.

SECTION 5. SERVICE AND TROUBLESHOOTING

Service

This section describes service procedures that can be performed by the user. Refer all service not described here to a qualified Martin technician.

CAUTION! RISK OF SHOCK

Disconnect power before servicing. Replace all parts after servicing.

The exterior of the fixture can reach temperatures up to 80° C (176° F) when operating at room temperature (25° C / 77° F). Always allow the fixture to cool for 30 minutes before handling.

Lamp replacement

To ensure optimum lamp life:

- Turn off lamp power whenever illumination is not required for extended periods of an hour or more. Fixture power may remain on when not in use.
- Always allow the lamp to warm up fully before turning it off.
- Avoid turning on several lamps at once.

The Imager can use the following discharge lamps. Installing any other lamp type may damage the fixture.

Lamp	CRI	Color Temp.	Average Life
Philips MSD 250	75	6700 K	3000 hours
Philips MSD 250/2	65	8500 K	3000 hours
Osram HSD 250/78	85	7800 K	3000 hours
Osram HSD 250/60	85	6000 K	2000 hours
Osram HSD 250/80	75-80	8000 K	3000 hours

To replace the lamp:

- 1 Disconnect the fixture from power and allow it to cool for 30 minutes before removing the lamp cover.

- 2 Remove the two thumb screws that hold the lamp holder in place at the back of the fixture.

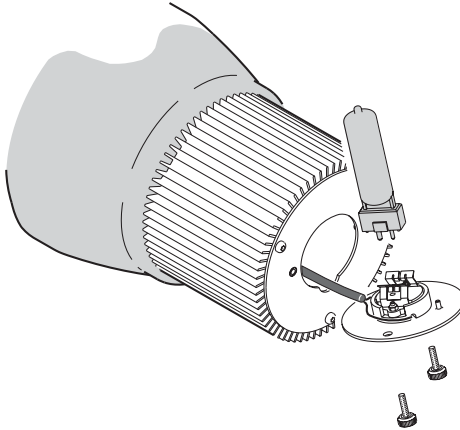

- 3 Gently remove the lamp holder and guide it out of the housing.
- 4 Remove the old lamp from the socket.
- 5 Holding the new lamp by its ceramic base - *do not touch the glass bulb* - insert it firmly and squarely into the lamp socket.
- 6 Clean the glass bulb with an alcohol wipe or a clean, lint-free cloth wetted with alcohol.
- 7 Gently insert the lamp and screw the holder into place.
- 8 We recommend that you activate the Lamp Hour Warning function on the Imager and that you set the expected number of hours of life the lamp has. This is done using the Personality menu on the Imager (see the *Imager user manual*). Remember to also reset the lamp hour counter using the Information menu on the Imager. When the lamp hour counter reaches:
 - 100 hours less than the expected life time of the lamp, the display on the Imager will start blinking LHR in the display. At this point you should change the lamp to avoid the risk of lamp explosion.
 - The expected life of the lamp, the lamp shuts off and can not be turned on again before the counter in the Imager is reset, or the predefined lamp hour warning level has been redefined.

Cleaning

Wash the aluminum housing of the Imager with a soft brush or sponge and a mild, non-abrasive car washing detergent. Rinse.

Cleaning the air filter in the Imager luminaire

The air filters can be found on the spine of the Imager and should be replaced regularly. You can order extra filters from your Martin Dealer (part number 91611079).

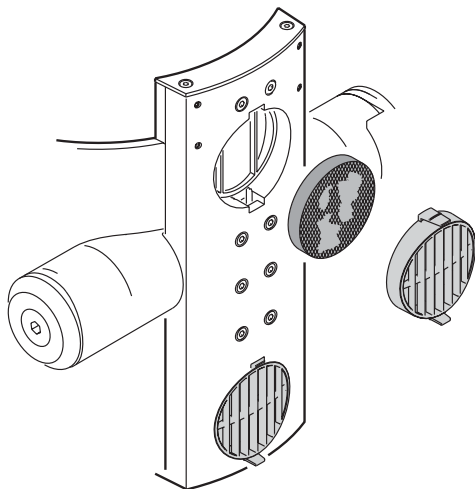

Firmware updates

Firmware updates are released when features are added. The latest version is available from the Support Area of the Martin Professional web site at <http://www.martin.dk>.

The installed firmware version number is displayed in the control panel under the InF/Uer menu.

Requirements

Firmware is installed using one of the following hardware devices, hereafter referred to as the "Uploader":

- Martin MP-2 Uploader
- PC using any DMX interface that supports the Software Uploader program (for example a Martin LightJockey or DABS 1 interface)

The following are required in order to install software:

- The Imager update file, available for download from the User Support Area of the Martin web site (<http://www.martin.dk>).

- The Software Uploader program, version 5.3 or later - supplied with the Martin MP-2, LightJockey, or available for download from the support pages for these products in the User Support Area of the Martin web site.

Important *In DMX or SA-mode (Stand Alone mode) the data link must be terminated.*

In IR-mode press the ID button for approximately 5 sec. then the fixtures will go into DMX-mode and the fixtures can be uploaded. Remove the IR-Remote receiver and terminate the link. After fixture power off the fixtures will be in IR-mode again.

For guidance on preparing a LightJockey, MP-2 or Software Uploader refer to the user documentation and online help for these products. Follow these instructions before proceeding to the next section.

Updating fixture firmware with the MP-2 Uploader

- 1 Connect a prepared MP-2 Uploader to the DMX link on the Imager. Apply power to the fixtures and the MP-2. Wait a few moments for the fixtures to reset.
- 2 Select `Read Memory Card` from the MP-2 main menu.
- 3 Use the buttons on the right to scroll through the card slots. Select the slot that holds the desired version of the Imager firmware.
- 4 Select `Update Software`. Select `Yes` to confirm.
- 5 Select `Update in DMX mode` to start the upload. The MP-2 initializes all connected Imagers.
- 6 After a successful upload the fixtures reset with the new software. If an error occurs and the fixtures do not reset, data was interrupted or corrupted during transmission. Perform a boot mode upload as described in the following section.

Boot sector upload

If the normal upload procedure does not work, or if the software update notes call for a boot sector update. Boot sector update mode needs to be set either in the control menu, or by moving a jumper on the PCB in the Imager.

Performing a boot sector update by moving a PCB jumper

- 1 Make sure the Imager is isolated from AC power.

- 2 Open the cover behind the control panel using a 2 mm Allen wrench to remove the 4 screws.

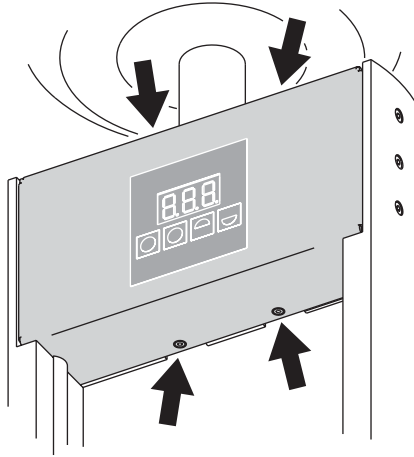

- 3 Referring to “Printed circuit board layout” on page 59, locate the jumper at position PL12. Move the jumper to the “ENABLE” position (the two pins closest to the fuses on the printed circuit board).
- 4 Perform a boot mode upload as described in the uploader manual.
- 5 When the upload is complete, disconnect the fixture from power and move the jumper at PL12 back to the “DISABLE” position (the two pins farthest away from the fuses on the printed circuit board).
- 6 Replace the cover and reapply power.

Performing a boot sector update via the control menu

- 1 Select the Utility (UtL) menu from the control menu.
- 2 Select Upload (UPL) and then select yES to place the fixture in Boot Upload Mode.
- 3 Perform a boot mode upload as described in the uploader manual.
- 4 When the upload is complete, use the control menu to disable Boot Upload Mode.

Printed circuit board layout

The PCB can be found behind the control panel.

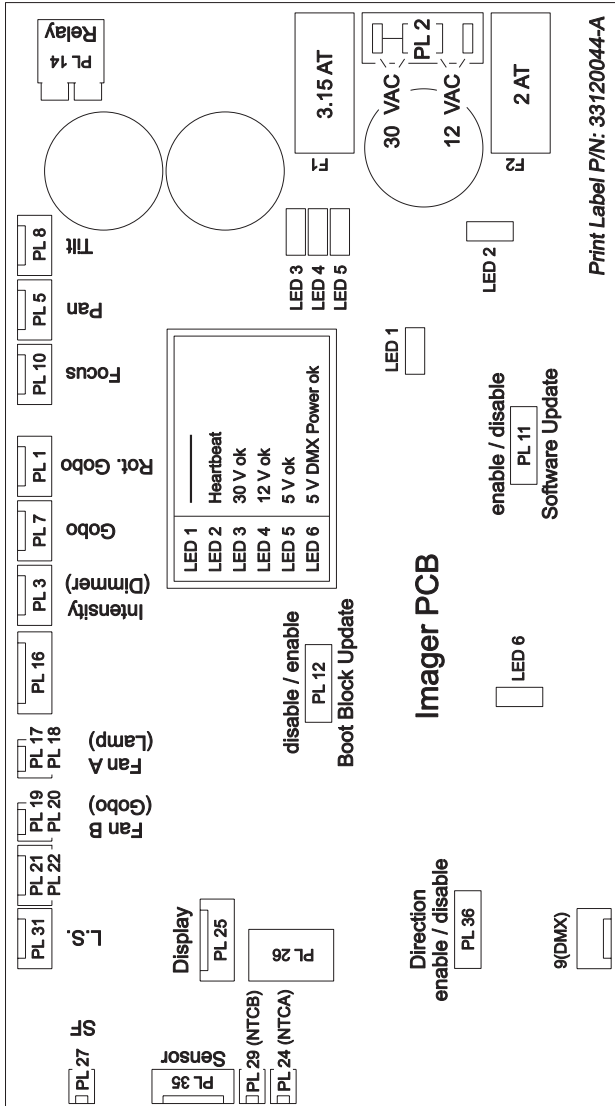

Troubleshooting

Problem	Probable cause(s)	Remedy
No response from fixture when power is applied.	No power to fixture.	Check power and data cables.
	Primary fuse blown in Base.	Replace fuse.
Fixture resets but does not respond correctly to controller (DMX mode operation).	Controller not connected.	Connect controller.
	Incorrect addressing of the fixtures.	Check address setting on fixture and controller.
	Bad data link connection.	Inspect cables and correct poor connections and/or broken cables.
	Data link not terminated.	Insert termination plug in output of last fixture.
	Defective fixture or 2 devices transmitting on link.	Bypass fixtures one at a time until normal operation is regained: unplug both connectors and connect them directly together.
Fixture does not reset correctly.	Electronic or mechanical failure.	Contact service technician.
No light, lamp cuts out intermittently, or burns out too quickly.	Lamp missing or blown.	Disconnect fixture and replace lamp.
	Fixture or lamp is too hot.	Allow fixture to cool. If problem persists, contact service technician.
	Incorrect power supply setting.	Check setting.

Error messages

Message in display	Error	Remedy
E E E	EPROM error	Contact your Martin dealer for service.
r A E	Memory error	Contact your Martin dealer for service.
F P E	FPGA error	Contact your Martin dealer for service.
d r E	Driver error	Contact your Martin dealer for service.

Message in display	Error	Remedy
LHE	Lamp hour expected life has been reached and the lamp shuts off.	Replace the lamp.
r t E	Real time clock error.	The battery on the mother board needs to be replaced. Contact your Martin dealer for service.
L E	Lamp error. After attempting to strike a lamp once and failing, the Imager will wait approximately 6 minutes (for the lamp to cool) and re-attempt to strike the lamp. If this fails the Lamp Error message will appear.	Replace the lamp if necessary
		Check and replace fuses if necessary
		Check that the fan is functioning and that there is enough space around the air vent.
		Issue a Lamp off command and wait 6 minutes before attempting to strike the lamp again manually.
	Contact your Martin dealer for service.	
L t E	Temperature error (lamp sensor) The lamp cannot be struck	Clean the air filters and check that there is enough space around the air vent before trying again. Contact your Martin dealer for service.
g t E	Temperature error (gobo sensor) The lamp cannot be struck	Clean the air filters and check that there is enough space around the air vent before trying again. Contact your Martin dealer for service.
F o E	Focus error	Contact your Martin dealer for service.
r g E	Gobo rotation error	Contact your Martin dealer for service.
g o E	Gobo error	Contact your Martin dealer for service.
Sh E	Lamp short error	The lamp cannot be turned off. Contact your Martin dealer.
L S E	Light sensor error	The light sensor is not working. Contact your Martin dealer for service.
L F E	Lamp fan error	The lamp fan speed is too low or too high. Contact your Martin dealer for service.
g F E	Gobo fan error	The gobo fan speed is too low or too high. Contact your Martin dealer for service.
L h u	Lamp hour warning	Replace the lamp if necessary

Message in display	Error	Remedy
L t u	Temperature warning (lamp sensor). Temperature around the lamp is too high.	<p>Check that there is enough space around the air vent.</p> <p>Check that the ambient temperature does not exceed 40° C (104° F).</p> <p>Contact your Martin dealer for service.</p>
g t u	Temperature warning (gobo sensor) Temperature around the gobo is too high.	<p>Check that there is enough space around the air vent.</p> <p>Check that the ambient temperature does not exceed 40° C (104° F).</p> <p>Contact your Martin dealer for service.</p>
H o t	Hot lamp warning	The lamp is too hot to be turned on. Wait for the lamp to cool before attempting to re-strike it.

SECTION 6. REFERENCE

Control menu structure

Default settings appear in bold.

Level 1	Level 2	Level 3	Effect (default = bold)	
Fixture address (Adr)	DMX: 1-512 & IR: 0-9		Select control address for both DMX and IR profile	
Profile (Pro)	DMX-mode (d1)		Set DMX mode (8-bit, tracking)	
	DMX-mode (d2)		Set DMX mode (16-bit, tracking)	
	IR-remote "send" (rCS)		Set IR-remote control "send" mode	
	IR-remote "recieve" (rCr)		Set IR-remote control "recieve" mode	
Stand alone (SA)	Enable SA (run)	Off (OFF)	Disable standalone operation	
		On (On)	Enable standalone operation	
	SA Execution (SAE)	Single fixture (Sin)	Fixture operates in isolation	
		Master (Snd)	Fixture is set master for program operation	
		Synchronized (Syn)	Fixture is set to synchronized program operation	
Adjust (Adj)	Reset (rSt)		Reset effects to home position	
	Lamp on (LOn)		Turn lamp on	
	Lamp off (LOF)		Turn lamp off	
	Intensity (Int)	Open (OPn)		Intensity 100%
		Closed (CLO)		Intensity 0%
	Focus (FOC)	Reset focus (rF)		
		Near (nEA)		
		Far (FAR)		
	Gobo wheel (GOB)	Reset gobo (rg)		
		Gobo 1 (g 1)		
		Gobo 4 (g 4)		

Rotating gobo (rgO)	Reset Gobo (rg)	
	Gobo 1 no rotation (g 1)	
	Gobo 1 slow (1rS)	
	Gobo 1 fast (1rF)	
	Gobo 2 no rotation (g 2)	
	Gobo 2 slow (2rS)	
	Gobo 2 fast (2rF)	
	Gobo 3 no rotation (g 3)	
	Gobo 3 slow (3rS)	
	Gobo 3 fast (3rF)	
	Gobo 4 no rotation (g 4)	
	Gobo 4 slow (4rS)	
	Gobo 4 fast (4rF)	
	Pan/tilt (P-t)	Position 1 (P1)
Position 1 (P2)		
Position 1 (P3)		
Position 1 (P4)		
Position 1 (P5)		
Position 1 (P6)		
Position 1 (P7)		

Personality (PEr)	DMX lamp off (LOF)	Off (OFF)	Disable lamp off without confirmation
		On (On)	Enable lamp off without confirmation
	DMX reset (rES)	Off (OFF)	Disable reset without confirmation
		On (On)	Enable reset without confirmation
	Auto lamp on (ALO)	Off (OFF)	Strike lamp from controller or display
		On (On)	Automatically strike lamp within 90sec from power on.
	Display (dIS)	Off (OFF)	Turn display off 2 minutes after key press
		On (On)	Keep display lit
	Store remote status (SrS)	Off (OFF)	Disable the store remote status feature.
		On (On)	Enable the store remote status feature.
	MC-X lamp off (nnO)	Off (OFF)	Disable MC-X lamp off
		On (On)	Enable MC-X button 7 lamp off
	Error messages (Err)	Off (OFF)	Error warnings disabled
		On (On)	Error an warning messages enabled
	Lamp Fan Temp. regulation (tFL)	Off (OFF)	Temperature fan regulation disabled
		On (On)	Lamp Fan Temperature regulation enabled
	Gobo Fan Temp. regulation (tFg)	Off (OFF)	Lamp Fan Temperature regulation disabled
		On (On)	Gobo Fan Temperature regulation enabled
	Temp warning (tE)	Off (OFF)	Gobo Fan Temperature regulation disabled
		On (On)	Temperature warnings enabled
	Lamp hour warning (LHr)	Off (OFF)	Lamp hour warning disabled
		On (On)	Enable power on warning and set value [1.000h] If time exceeds +10% over the set value, it will not only give warning but also prevent lamp strike.
	Restore default (FAC)	Yes (yES)	Restore default personality settings
		No (no)	
	Reset counters (rEC)	Yes (yES)	Reset all counters.
		No (no)	

Info (InF) only display not MP2	(UEr)		Read firmware version number
	(tLA)	(CUr)	Read current lamp temperature [x°C]
		(tOt)	Read maximum lamp temperature since fabrication [x°C]
		(rES)	Read maximum lamp temperature since reset [x°C]
	(tgo)	(CUr)	Read current gobo temperature [x°C]
		(tOt)	Read maximum gobo temperature since fabrication [x°C]
		(rES)	Read maximum gobo temperature since reset [x°C]
	(Hr)	(tOt)	Read power-on hours since fabrication
		(rES)	Read power-on hours since counter was reset
	(LHr)	(tOt)	Read lamp hours since fabrication
		(rES)	Read lamp hours since counter was reset
		(UAL)	Read set value for warning
	(LSt)	(tOt)	Read lamp strikes since fabrication
		(rES)	Read lamp strikes since counter was reset
Utility (UtL)	(UPL)	Yes (yES)	Set fixture to Boot Upload mode.
		No (no)	
Test (tSt)	(Pcb)	Yes (yES)	Test PCB. For service use only
		No (no)	

DMX protocols

The DMX protocols each have two modes:

- *DMX mode 1* uses 9 channels and does not allow fine adjustment of movement and effects.
- *DMX mode 2*, which is the default, uses 12 channels and allows fine adjustment of movement and effects.

The DMX mode that is used is specified using the Profile menu in the control panel (see “Control menu structure” on page 64).

Choose the protocol appropriate to the your Imager model:

- “Imager DMX-Gobo Wheel” on page 69.
- “Imager DMX-Gobo Wheel with moving-mirror fitted” on page 70.
- “Imager DMX-Gobo” on page 72.
- “Imager DMX-Gobo with moving-mirror fitted” on page 73.

Imager DMX-Gobo Wheel

Start code = 0

DMX2	DMX 2	Value	Percent	Function
1		0 - 208 208 - 217 218 - 227 228 - 237 238 - 247 248 - 255	0 - 81 81 - 85 85 - 87 89 - 93 93 - 97 97 - 100	Reset, Lamp On/Off Reserved (no change) Reset fixture Reserved (no change) Lamp power on Reserved (no change) Lamp power off: T>= for 5 seconds. <i>If reset or power off are disabled, confirm on channel 3, by selecting image 4, either in indexed or continuous rotation, and focus in near position (channel 5 or 6).</i>
2		0 - 255	0 - 100	Intensity Intensity 0→100%
3		0 - 19 20 - 39 40 - 59 60 - 79 80 - 99 100 - 119 120 - 139 140 - 159 160 - 198 199 - 237 238 - 255	0 - 7 7 - 15 15 - 23 23 - 31 31 - 39 39 - 46 47 - 54 55 - 62 63 - 78 78 - 93 93 - 100	Image Selection Image 1, indexed rotation Image 2, indexed rotation Image 3, indexed rotation Image 4, indexed rotation Image 1, continuous rotation Image 2, continuous rotation Image 3, continuous rotation Image 4, continuous rotation CW (Clockwise) wheel rot., slow→fast CCW wheel rot. fast→slow Reserved (no change)
4		0 - 255 0 - 2 3 - 127 128 - 252 253 - 255	0 - 100 0 1 - 50 50 - 99 99 - 100	Image Rotation (select indexed image rotation, on channel 3) Coarse position index (MSB), Min→Max Rotation Velocity (select cont. image rotation, on channel 3) No rotation CW rotation, slow→fast CCW rotation, fast→slow No rotation
	5	0-255	0-100	Image Rotation, Fine Position Fine position index (LSB), Min→Max
5	6	0-255	0-100	Focus Infinity→near
6	7	0-255	0-100	Reserved (no change)
	8	0-255	0-100	Reserved (no change)
7	9	0-255	0-100	Reserved (no change)
	10	0-255	0-100	Reserved (no change)
8	11	0-255	0-100	Reserved (no change)

Start code = 0

DMX2	DMX 2	Value	Percent	Function
9	12	0 - 2 3 - 251 252 - 255	0 1 - 96 97 - 100	Image and Focus Speed Tracking mode Fast→slow Blackout while moving

Imager DMX-Gobo Wheel with moving-mirror fitted

Start code = 0

DMX 1	DMX 2	Value	Percent	Function
1		0 - 208 208 - 217 218 - 227 228 - 237 238 - 247 248 - 255	0 - 81 81 - 85 85 - 87 89 - 93 93 - 97 97 - 100	Reset, Lamp On/Off Reserved (no change) Reset fixture Reserved (no change) Lamp power on Reserved (no change) Lamp power off: T >= for 5 seconds <i>If reset or power off are disabled, confirm on channel 3, by selecting image 4, either in indexed or continuous rotation, and focus in near position (channel 5 or 6).</i>
2		0 - 255	0 - 100	Intensity Intensity 0→100%
3		0 - 19 20 - 39 40 - 59 60 - 79 80 - 99 100 - 119 120 - 139 140 - 159 160 - 198 199 - 237 238 - 255	0 - 7 7 - 15 15 - 23 23 - 31 31 - 39 39 - 46 47 - 54 55 - 62 63 - 78 78 - 93 93 - 100	Image Selection Image 1, indexed rotation Image 2, indexed rotation Image 3, indexed rotation Image 4, indexed rotation Image 1, continuous rotation Image 2, continuous rotation Image 3, continuous rotation Image 4, continuous rotation CCW wheel rotation, slow→fast CW (Clockwise) wheel rot., fast→slow Reserved (no change)
4		0 - 255 0 - 2 3 - 127 128 - 252 253 - 255	0 - 100 0 1 - 50 50 - 99 99 - 100	Image Rotation (select indexed image rotation, on channel 3) Coarse position index (MSB), Min→Max Rotation Velocity (select cont. image rotation, on channel 3) No rotation CCW rotation, slow→fast CW rotation, fast→slow No rotation
	5	0-255	0-100	Image Rotation, Fine Position Fine position index (LSB), Min→Max

DMX 1	DMX 2	Value	Percent	Function
5	6	0-255	0-100	Focus Infinity→near
6	7	0-255	0-100	Pan Left→right (128 = neutral)
	8	0-255	0-100	Pan fine (LSB) Left→right
7	9	0-255	0-100	Tilt Up→down (128 = neutral)
	10	0-255	0-100	Tilt fine (LSB) Up→down
8	11	0 - 2 3 - 251 252 - 255	0 1 - 98 99 - 100	Pan/Tilt Speed Tracking mode Fast→slow Blackout while moving
9	12	0 - 2 3 - 251 252 - 255	0 1 - 96 97 - 100	Image and Focus Speed Tracking mode Fast→slow Blackout while moving

Imager DMX-Gobo

Start code = 0

DMX2	DMX 2	Value	Percent	Function
1		0 - 208 208 - 217 218 - 227 228 - 237 238 - 247 248 - 255	0 - 81 81 - 85 85 - 87 89 - 93 93 - 97 97 - 100	Reset, Lamp On/Off Reserved (no change) Reset fixture Reserved (no change) Lamp power on Reserved (no change) Lamp power off: T>= for 5 seconds. <i>If reset or power off are disabled, confirm by setting DMX-channel 3 to any value in the ranges 60-79 or 140-159, and focus in near position. (channel 5 or 6).</i>
2		0 - 255	0 - 100	Intensity Intensity 0→100%
3		0 - 79 80 - 159 160 - 255	0 - 31 31 - 62 63 - 100	Image Selection Image, indexed rotation Image, continuous rotation Reserved (no change)
4		0 - 255	0 - 100	Image Rotation (select indexed image rotation, on channel 3) Coarse position index (MSB), Min→Max Rotation Velocity (select cont. image rotation, on channel 3) 0 No rotation 3 - 127 1 - 50 CW rotation, slow→fast 128 - 252 50 - 99 CCW rotation, fast→slow 253 - 255 99 - 100 No rotation
	5	0-255	0-100	Image Rotation, Fine Position Fine position index (LSB), Min→Max
5	6	0-255	0-100	Focus Infinity→near
6	7	0-255	0-100	Reserved (no change)
	8	0-255	0-100	Reserved (no change)
7	9	0-255	0-100	Reserved (no change)
	10	0-255	0-100	Reserved (no change)
8	11	0-255	0-100	Reserved (no change)
9	12	0 - 2 3 - 251 252 - 255	0 1 - 96 97 - 100	Image and Focus Speed Tracking mode Fast→slow Blackout while moving

Imager DMX-Gobo with moving-mirror fitted

Start code = 0

DMX 1	DMX 2	Value	Percent	Function
1		0 - 208 208 - 217 218 - 227 228 - 237 238 - 247 248 - 255	0 - 81 81 - 85 85 - 87 89 - 93 93 - 97 97 - 100	Reset, Lamp On/Off Reserved (no change) Reset fixture Reserved (no change) Lamp power on Reserved (no change) Lamp power off: T >= for 5 seconds <i>If reset or power off are disabled, confirm by setting DMX-channel 3 to any value in the ranges 60-79 or 140-159, and focus in near position. (channel 5 or 6).</i>
2		0 - 255	0 - 100	Intensity Intensity 0→100%
3		0 - 79 80 - 159 160 - 255	0 - 31 31 - 62 63 - 100	Image Selection Image, indexed rotation Image, continuous rotation Reserved (no change)
4		0 - 255 0 - 2 3 - 127 128 - 252 253 - 255	0 - 100 0 1 - 50 50 - 99 99 - 100	Image Rotation (select indexed image rotation, on channel 3) Coarse position index (MSB), Min→Max Rotation Velocity (select cont. image rotation, on channel 3) No rotation CCW rotation, slow→fast CW rotation, fast→slow No rotation
	5	0-255	0-100	Image Rotation, Fine Position Fine position index (LSB), Min→Max
5	6	0-255	0-100	Focus Infinity→near
6	7	0-255	0-100	Pan Left→right (128 = neutral)
	8	0-255	0-100	Pan fine (LSB) Left→right
7	9	0-255	0-100	Tilt Up→down (128 = neutral)
	10	0-255	0-100	Tilt fine (LSB) Up→down
8	11	0 - 2 3 - 251 252 - 255	0 1 - 98 99 - 100	Pan/Tilt Speed Tracking mode Fast→slow Blackout while moving

DMX 1	DMX 2	Value	Percent	Function
9	12	0 - 2	0	Image and Focus Speed
		3 - 251	1 - 96	Tracking mode
		252 - 255	97 - 100	Fast→slow Blackout while moving

Specifications - Imager

Physical

Length	726 mm (28.6 in.)
Width	242 mm (9.5 in.)
Weight (Imager DMX Gobo Wheel)	9.9 kg (21.8 lbs)
Weight (Imager DMX Gobo)	9.7 kg (21.4 lbs)

Installation

Mounting device	Imager J-Box
Orientation	Ceiling mount

Minimum distance to combustible materials	1 m (39 in)
Minimum distance to illuminated surfaces	0.5 m (20 in)

Construction

Imager housing	Aluminum and plastic
----------------	----------------------

Thermal

Maximum ambient temperature (Ta)	40° C (104° F)
Maximum surface temperature, steady state, Ta=40° C	100° C (212° F)

Source

Lamp	250 W discharge
Approved models	Philips MSD 250
	Philips MSD 250/2
	Osram HSD 250/78
	Osram HSD 250/60
	Osram HSD 250/80

Power supply

Power source	Imager Base via Imager J-Box
PCB fuses	3.15 AT, 2 AT

Dynamic effects

Dimmer
Gobo rotation, continuous or to indexed position
Pan and tilt (with optional moving-mirror)
Focus

Gobos

Size	D
Outside diameter	53.3 mm (2.10 in.)
Maximum image diameter	40 mm (1.57 in.)
Maximum thickness	2 mm
Material	metal or glass

Photometrics

Standard beam angle	23° , focal length = 100 mm (3.9 in.)
Optional beam angle	15° lens, focal length = 150 mm (5.9 in.)
Optional beam angle	32° lens, focal length = 70 mm (2.75 in.)

Size of a projected image using a gobo of a given size:

$$\text{projected image size} = \frac{\text{gobo image size} \times \text{projected distance}}{\text{focal length}}$$

Gobo image size required to achieve a projected image size:

$$\text{gobo image size} = \frac{\text{projected size} \times \text{focal length}}{\text{projected distance}}$$

Control & Programming

Control options	DMX-512, stand-alone, synchronous operation
Receiver	RS-485
Setting and addressing	3-digit LCD control panel
Firmware update	Serial upload (.MU3)
Data input	RJ-45
Data output	RJ-45
DMX channels	9 or 12

Ordering information

Imager, Base	<i>contact your dealer</i>
Imager DMX Gobo Wheel	P/N 90540000
Imager DMX Gobo	P/N 90540100
Imager DMX Effect (<i>confirm availability with your dealer</i>)	P/N 90540200
Imager SA-Gobo (<i>confirm availability with your dealer</i>)	P/N 90540300
Imager SA-Effect (<i>confirm availability with your dealer</i>)	P/N 90540400
Imager J-box	P/N 91611073
Moving-mirror for Imager	P/N 91611069

Included items

- User manual
- Osram HSD 250/80
- Beacon gobo

Accessories

Martin infrared remote control transmitter	P/N 90760010
Martin infrared remote control receiver	P/N 91611047
MP-2 uploader:	P/N 90758420
MC-X Controller, 220-245V/50Hz	P/N 90718200
MC-X Controller, 110-120V/60Hz	P/N 90718300
15 degree lens	P/N 91611074
32 degree lens	P/N 91611075
Slide projection kit	P/N 91611076
Remote control upgrade kit	P/N 91614008
DMX-RJ45 converter	<i>contact your dealer</i>
RJ45-DMX converter	<i>contact your dealer</i>
RJ45 network terminator	<i>contact your dealer</i>
Air filters	P/N 91611079
Color temperature correction filter 5500-3400K	P/N 46402019
Blue 101 color filter	P/N 46402001
Blue 104 color filter	P/N 46402017
Blue 107 color filter	P/N 46402014
Blue 108 color filter	P/N 46402015
Blue 111 color filter	P/N 46402013
1/2 Minus Green color filter	P/N 46402024
Green 201 color filter	P/N 46402022
Green 204 color filter	P/N 46402005
Green 205 color filter	P/N 46402003
Green 206 color filter	P/N 46402007
Yellow 603 color filter	P/N 46402004
Orange 302 color filter	P/N 46402010
Orange 306M color filter	P/N 46402009
Red 304 color filter	P/N 46402002
Red 308 color filter	P/N 46402011
Magenta 507 color filter	P/N 46402012
Pink 312 color filter	P/N 46402006
Purple 502 color filter	P/N 46402018

The number next to each color filter is an OCLI (Optical Coating Laboratory, Inc.) reference number.



www.martin-architectural.com • Olof Palmes Allé 18 • 8200 Aarhus N • Denmark
Tel: +45 8740 0000 • Fax +45 8740 0010