

Imager Base

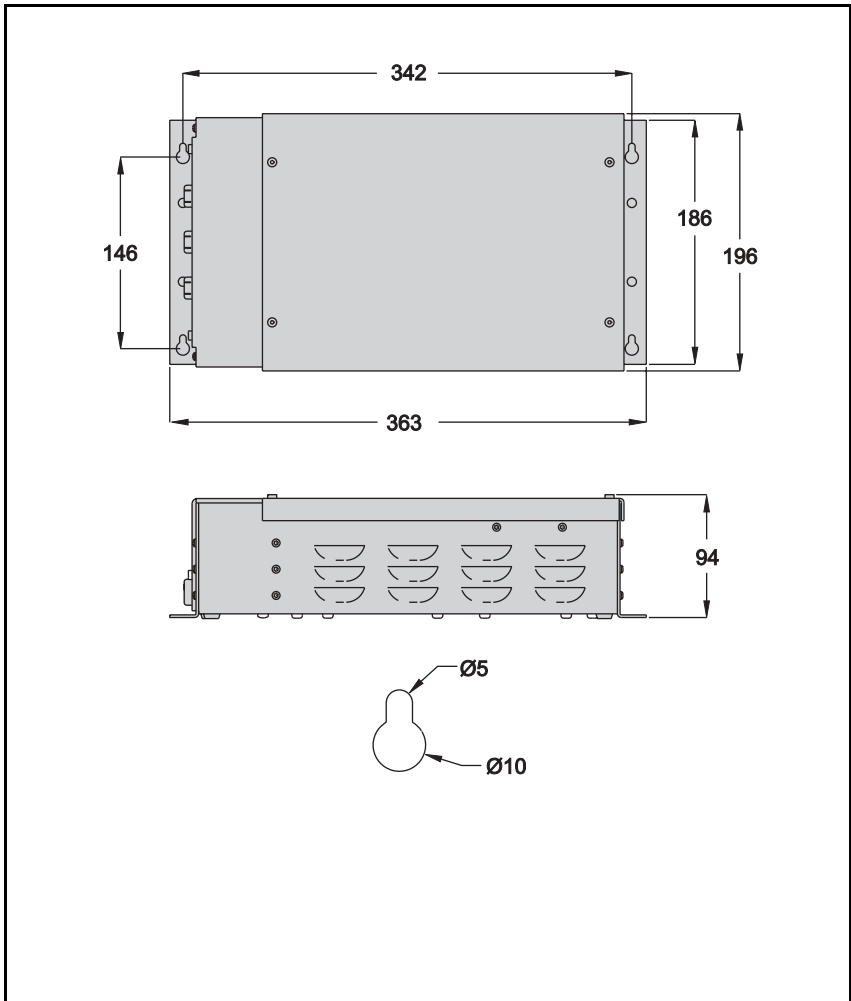

user manual

Measurements are in millimeters



© 2003 Martin Professional A/S, Denmark.

All rights reserved. No part of this manual may be reproduced, in any form or by any means, without permission in writing from Martin Professional A/S, Denmark.

Printed in Denmark.

P/N 35000128, Rev A

Introduction

Thank you for selecting the Martin Imager Base. The Imager Base supplies power to a luminaire in the Martin Imager series.

Safety information

Warning! *This product is for professional use only.*

Not for use in dwellings.

These products present risks of lethal or severe injury due to fire and heat, electric shock and falls. **Read this manual** before powering or installing these fixtures, follow the safety precautions listed below and observe all warnings in this manual and on the fixtures. If you have questions about how to operate these fixtures safely, please contact your Martin dealer or call the Martin 24-hour service hotline at +45 70 200 201.

Protection from electric shock

- Disconnect the fixtures from AC power before removing or installing fuses, or any part, and when not in use.
- Always ground (earth) the fixture electrically.
- Use only a source of AC power that complies with local building and electrical codes and has both overload and ground-fault protection.
- Do not expose the fixture to rain or moisture.
- Refer all service to a Martin service technician.

Protection from burns and fire

- Never attempt to bypass the thermostatic switch or fuses. Always replace defective fuses with ones of the specified type and rating.
- Provide a minimum clearance of 0.1 meters (4 inches) around air vents.
- Do not modify the fixture or install other than genuine Martin parts.
- Do not operate the fixture if the ambient temperature (T_a) exceeds 40° C (104° F).

Protection from injury due to falls

- Verify that all external covers and rigging hardware are securely fastened
- Block access below the work area whenever installing or removing the fixture.

Installation

This section describes how to mount the fixture and connect it to AC power. It contains the following sections:

- “Mounting orientation and location”
- “Configuring power”
- “Connecting the Imager Base to the Imager J-Box” on page 8

These procedures shall be performed by qualified professionals.

This product must be installed in accordance with the applicable installation code by a person familiar with the construction and operation of this product and the hazards involved.

Mounting orientation and location

The Imager Base is connected to an Imager luminaire via an Imager J-Box. The cable distance between the Imager Base and the Imager J-Box can be up to 16 meters (52 feet).

Not for use in dwellings.

This product must be mounted or supported independently of an outlet box.

The product must not operate in an area where the ambient temperature exceeds $T_a=40^{\circ}\text{C}$ (104°F).

Screw or bolt the Imager Base fast to a surface using 4 units of 4 mm (1/5 in.) hardware.

Keep in mind that access to the fixture may be necessary from time-to-time, for example, if a fuse blows.

Configuring power

Warning *For protection from electric shock, the fixture must be grounded (earthed). The power supply shall have overload and ground-fault protection.*

Consult a qualified electrician to ensure correct branch circuit conductor.

Prerequisites

You need to purchase the following cables in lengths long enough (up to 16 metres/52 feet) to connect the Imager Base to the Imager J-Box:

- Mains power input cable - 3 x 1 mm² (AWG 18)
- Lamp power out cable - 3 x 1 mm² (AWG 18)
- Low voltage output cable - 4 x 0.75 mm² (AWG 18)

Configure power settings

Verify that power supply settings match local AC supply. The Imager Base has switch-selectable settings to configure the power supply for local conditions. The factory-default setting is indicated on the serial number label. Always use the setting that is closest to the local AC supply.

- 1 Ensure that the Imager Base is disconnected from power.
- 2 Remove the four cover bolts on the top of the Imager Base with a 2.5 mm Allen wrench.

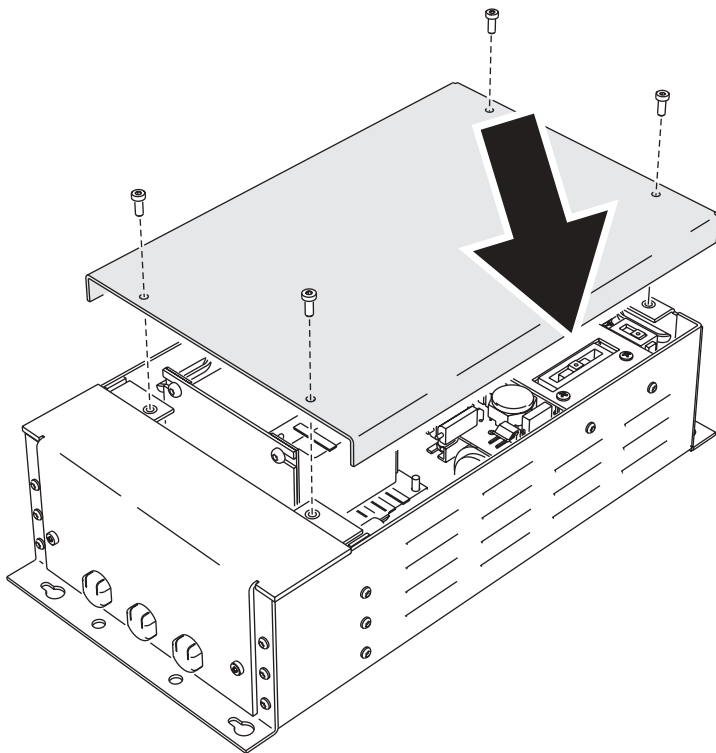

- 3 Set the 5-position switch to the setting closest to the AC voltage. Use the higher setting if the voltage is halfway between 2 settings. For example, use

the 230 V setting instead of the 210 V setting for operation with 220 V power.

- 4 Set the 2-position switch to the AC frequency (50 / 60 Hz).
- 5 Replace the cover and apply a new power setting label to the serial number label.

Install power input and output cables

To connect power cables to the Imager Base:

- 1 Remove the cable-terminal access cover using a 2.5 mm Allen wrench.

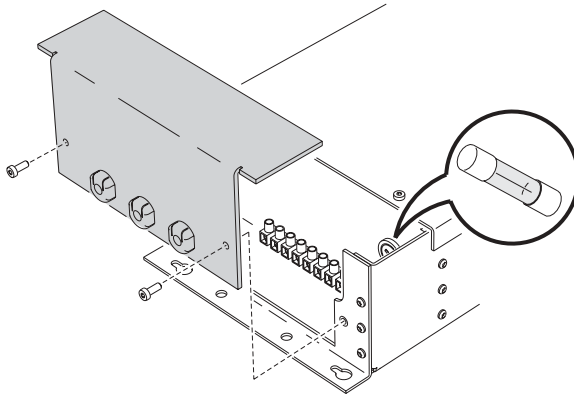

- 2 Remove the three cable glands from the holes in the cable-terminal access cover.

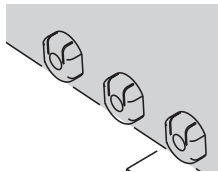

- 3 Break open the cable glands and place one around each cable.
- 4 Using the wiring identification label as a guide, pass the cables/cable glands through their respective holes in the cable-terminal access cover.
- 5 Screw the respective leads into position on the terminal block.

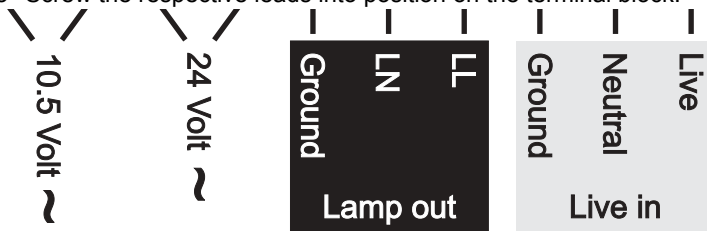

The following table below shows some wire identification schemes.

Wire (EU)	Wire (US)	Function
brown	black	live
blue	white	neutral
yellow/green	green	ground

- 6 Replace the cable-terminal access cover and screw it into place using a 2.5 mm Allen wrench.

Connecting the Imager Base to the Imager J-Box

Refer to the Martin *Imager J-Box installation note* (P/N 35000559) for instructions on connecting the power cables from the Imager Base to the J-Box.

Service

CAUTION! RISK OF SHOCK

Disconnect power before servicing. Replace all parts after servicing.

Fuse replacement

Warning! Never replace fuses with ones of a different rating!

The main fuse is a 6.3 AT fuse located in a holder accessible under the cable-terminal access cover.

Replacing the main fuse

Main fuse replacement requires a 2.5 mm Allen wrench, a small flat-head screw driver and a 6.3 AT fuse:

- 1 Disconnect the fixture from mains power.
- 2 Remove the cable-terminal access cover using a 2.5 mm Allen wrench.

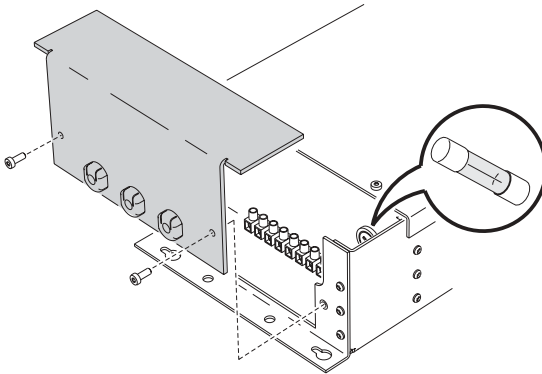

- 3 Open the fuse holder using a small flat-head screwdriver.
- 4 Remove and replace the 6.3 AT fuse.
- 5 Close the fuse holder.
- 6 Before reapplying mains power, replace the cable-terminal access cover and screw it into place using a 2.5 mm Allen wrench.

Specification - Imager Base

Physical

Length	363 mm (14.3 in)
Width	196 mm (7.7 in)
Height	94 mm (3.7 in)
Weight	8.5 kg (18.7 lbs)

Construction

Housing	Steel
---------	-------

Installation

Orientation	any
Required mounting hardware	4 x 5mm hardware (not supplied)
Maximum cable separation between Imager Base and Imager J-Box	16 m (52 ft)

Thermal

Maximum ambient temperature (Ta)	40° C (104° F)
----------------------------------	----------------

AC Supply

Mains power input cable	3 x 1 mm2 (AWG 18)
Power supply options	100/120/208/230/250 V, 50/60 Hz
Mains fuse	6.3 AT

Power output cables

Lamp power out cable	3 x 1 mm2 (AWG 18)
Low voltage output cable	4 x 0.75 mm2 (AWG 18)

Typical power and current

Measurement conditions. . . Imager Base connected to an Imager DMX Gobo Wheel	
100 V, 50 Hz	269 W, 3.1 A, PF 0.9
100 V, 60 Hz	233 W, 2.4 A, PF 1.0
120 V, 50 Hz	265 W, 2.4 A, PF 0.9
120 V, 60 Hz	236 W, 2.3 A, PF 0.9
208 V, 50 Hz	269 W, 1.6 A, PF 0.8
208 V, 60 Hz	233 W, 1.2 A, PF 0.9
230 V, 50 Hz	274 W, 1.3 A, PF 0.9
230 V, 60 Hz	237 W, 1.3 A, PF 0.8
250 V, 50 Hz	271 W, 1.2 A, PF 0.9
250 V, 60 Hz	236 W, 1.1 A, PF 0.8

* These measurements have a margin of error of +/- 10%

* V = volts, Hz = hertz, W = watts, A = amps, PF = power factor

Ordering information

Imager, Base	P/N 907210xx
Imager DMX Gobo Wheel	P/N 90540000
Imager DMX Gobo	P/N 90540100
Imager DMX Effect (<i>confirm availability with your dealer</i>)	P/N 90540200
Imager SA-Gobo (<i>confirm availability with your dealer</i>)	P/N 90540300
Imager SA-Effect (<i>confirm availability with your dealer</i>)	P/N 90540400
Imager J-box	P/N 91611073
Moving-mirror for Imager	P/N 91611069

Included items

User manual

