

MAC 250™ Beam Kit Installation Guide

Introduction

This Installation Guide explains how to install the MAC 250 Beam™ Upgrade Kit to convert a standard Martin Professional™ MAC 250 Wash™ to a MAC 250 Beam model. Installation only takes a few minutes. A fixture software update is required if the installed software version is earlier than v. 1.4.0.

If you keep the standard components you remove, the MAC 250 Beam components can be uninstalled and the fixture returned to standard MAC 250 Wash configuration at any time.

The MAC 250 Beam Kit has part number P/N 91610101.

For the latest documentation and information about this and all Martin Professional products, please visit the Martin website at www.martin.com.



Warning! The MAC 250 Beam has a much more intense light beam than the standard MAC 250 Wash. Do not use it to illuminate any surface closer than 3.5 m (11 ft. 6 ins.) from the front of the head, or you may create a fire risk.



Make sure that the front lens does not face the sun directly for longer than a few seconds at any time during daylight hours. The Beam lens can focus the sun's rays inside the fixture, causing internal damage and creating a possible fire risk.

Apart from the new minimum distance to illuminated surfaces specified above, follow all the other safety precautions in the MAC 250 Wash user manual when installing the MAC 250 Beam Kit and using the modified product. The user manual is supplied with MAC 250 Wash fixtures, and the latest revision of the user manual is also available for download from the Product Support page for the MAC 250 Wash at www.martin.com

Disconnect the fixture from power and allow to cool for at least 20 minutes before starting work.

The MAC 250 Beam Kit must be installed by qualified professional technicians only. Read all of this Installation Guide carefully before starting to install the Kit.

If you have any questions about how to install the MAC 250 Beam Kit or use the MAC 250 Beam safely, please contact your local Martin distributor (see www.martin.com/distributors for details) or call the Martin 24-hour service hotline on +45 8740 0000, or in the USA on 1-888-tech-180.

Important! Do not get oil or grease onto optical components. If necessary, clean components with 99.9% isopropyl alcohol.

© 2009-2010 Martin Professional A/S. Olof Palmes Allé 18, DK-8200 Aarhus N, Denmark. Information subject to change without notice.

Martin Professional A/S and all affiliated companies disclaim liability for any injury, damage, direct or indirect loss, consequential or economic loss or any other loss occasioned by the use of, inability to use or reliance on the information contained in this installation note. The Martin logo, the Martin name and all other trademarks in this document pertaining to services or products by Martin Professional A/S or its affiliates and subsidiaries are trademarks owned or licensed by Martin Professional A/S or its affiliates or subsidiaries.

P/N 35000607 Rev. F

Overview

The MAC 250 Beam Upgrade Kit contains the following items:

- MAC 250 Beam front lens assembly, P/N 62409076
- MAC 250 Beam lens bracket assembly, P/N 62420240
- Four M4 x 12 Torx 20 button-head screws, P/N 08070710
- Set of six beam effect gobos for MAC 250 Beam, P/N 62420250
- Aperture plate with sunlight shield, MAC 250 Beam, P/N 23819530
- Warning label (min. distance to illuminated surfaces), P/N 33150092

Keep the protective packaging from the front lens assembly for re-use when packing the fixture in a MAC 250 flightcase or storing the assembly.

Tools required

Screw sizes given in this Installation Guide are indicative only.

The following tools are normally required to install the standard MAC 250 Beam Kit. However, if screws have been replaced during service, for example, you may find that other tools are required.

- Pozidriv PZ1 and PZ2 screwdrivers
- Torx TX20 screwdriver

Installation procedure

To install the MAC 250 Beam components in a standard MAC 250 Beam fixture:

1. Disconnect the fixture from power and allow it to cool.
2. See Figure 1. Release the head cover retaining screws (arrowed) and remove both head covers. You can either let the head covers hang on their safety cables or unclip their safety cables and remove them completely, whichever is more convenient.
3. Apply the tilt lock with the head topside up (in this position the text on the back of the head is the right way up).
4. See Figure 2. Remove the four crosshead retaining screws from the front lens assembly and remove the front lens. The screws have Loctite applied at the factory, so take care when removing them. Store the front lens for possible re-use if the fixture is to be returned to standard MAC 250 Wash configuration at a later time. You can send the screws for scrap metal recycling, because new Torx screws are supplied in the Kit.

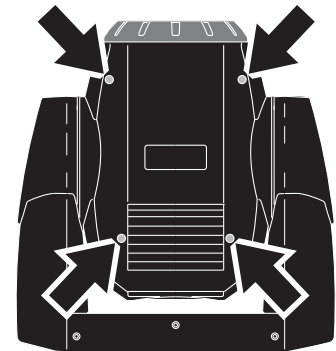

Figure 1

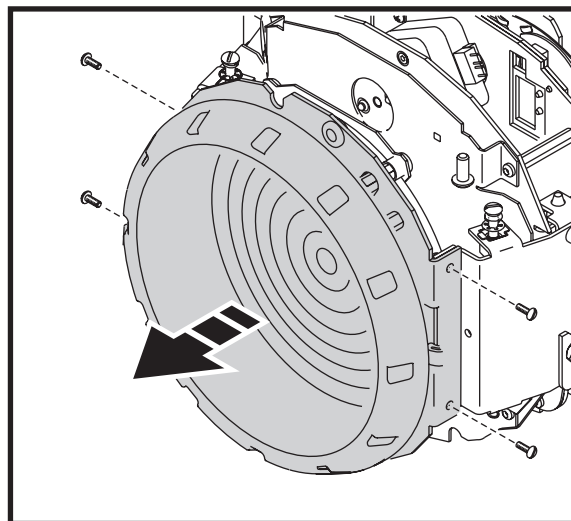

Figure 2

5. See Figure 3. Fasten the new front lens mounting bracket (P/N 62420240) supplied in the Kit to the front of the head using the four M4 X 12 Torx 20 screws (P/N 08070710) also supplied in the Kit. Apply a very small quantity of Loctite to the threads before tightening the screws.

If you reinstall the original front lens at a later date to return the fixture to standard MAC 250 Wash configuration, re-use these Torx screws.

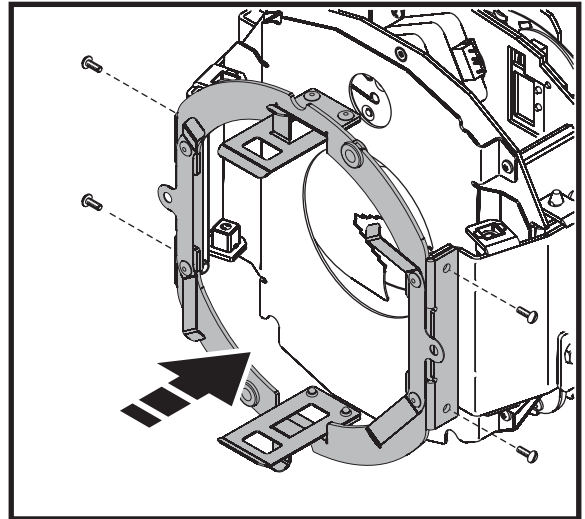

Figure 3

6. See Figure 4. Remove the four screws (arrowed) that hold the aperture plate in place inside the front of the head. See Figure 5. Remove the aperture plate and install the new aperture plate with shield plate (P/N 23819530) supplied in the Kit in its place, re-using the original four screws. The shield plate in the aperture plate must face upwards as illustrated to protect the wiring in the head from sunlight that might be focused into the head by the new front lens assembly.

If you reinstall the original front lens at a later date to return the fixture to standard MAC 250 Wash configuration, you must remove the new aperture plate together with the new front lens assembly.

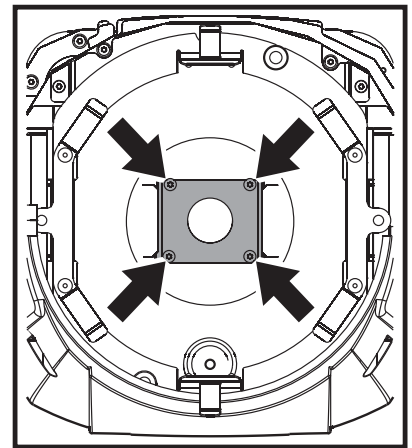

Figure 4

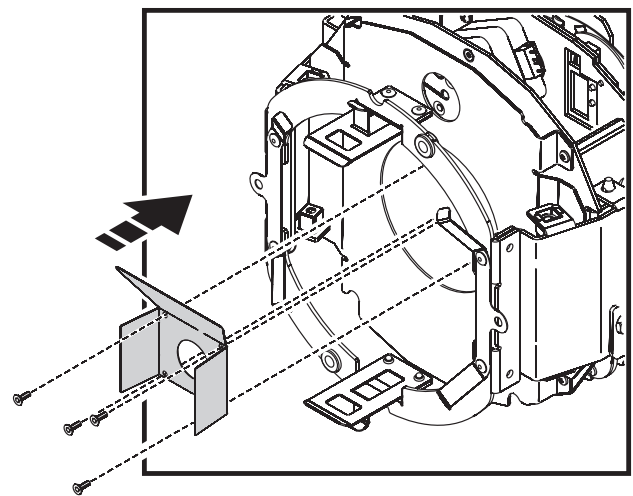
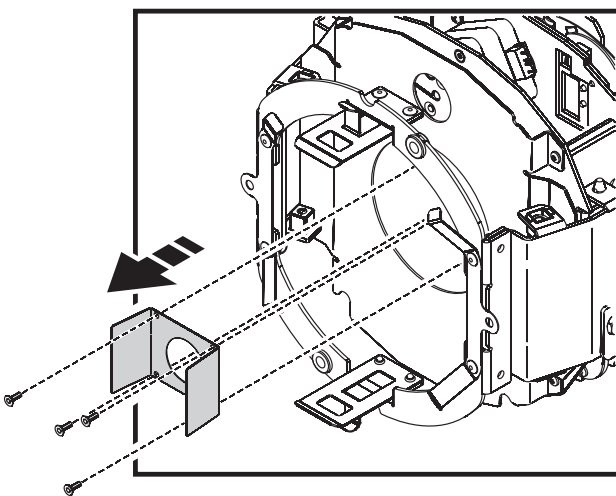

Figure 5

7. A set of six beam effect gobos (P/N 62420250) is supplied in the Kit. See Figure 6. To install a beam effect gobo, remove a color filter from the color wheel by pressing it gently away from its retaining tabs (A) and lifting it carefully out of the color wheel (B).
8. Filters and gobos have small beads of silicone applied to them to act as cushions. If a bead of silicone from a color filter has become stuck to the color wheel, remove it and replace it on the color filter.
9. Insert gobos with the silicone beads facing the color wheel with reference to Figure 7 and to the illustration on the last page of this guide. Store the original color filters safely for possible future re-use.

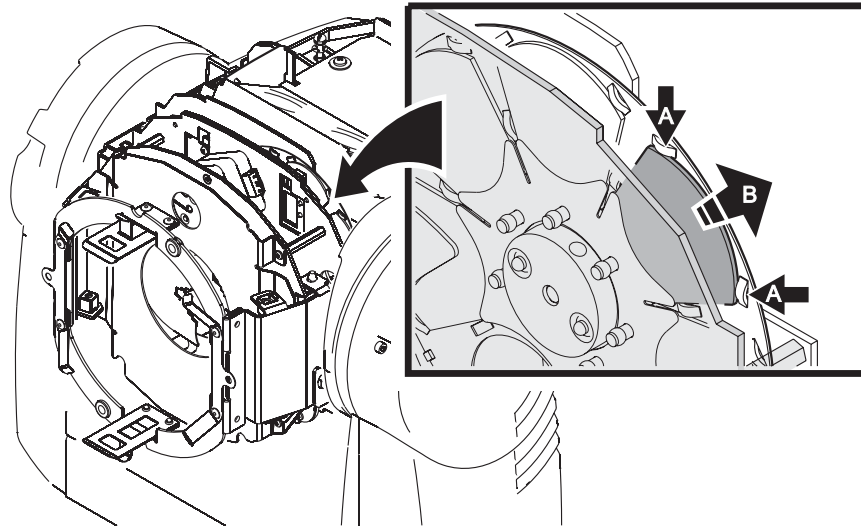

Figure 6

10. We recommend that you install beam effect gobos in the color wheel in the positions seen from the lamp side shown in Figure 7 in all the fixtures you modify, so that all MAC 250 Beam fixtures will have identical behavior under DMX control. A copy of this illustration is included on the last page of this guide as a reference for lighting designers and lighting desk operators.

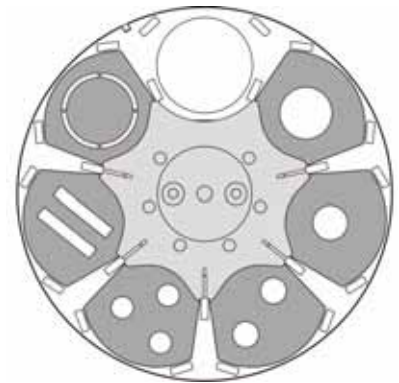

Figure 7

11. See Figure 8. The new front lens assembly (P/N 62409076) has a safety cable with a carabiner clip. Attach the clip to the head using either of the two holes (A) provided in the new front lens mounting bracket, then push the clip flat (B) to give space for the front lens assembly.

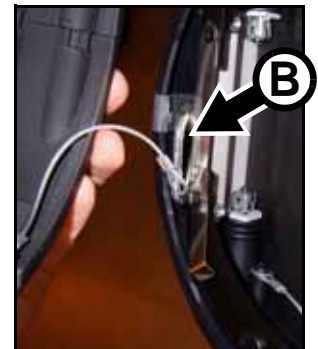
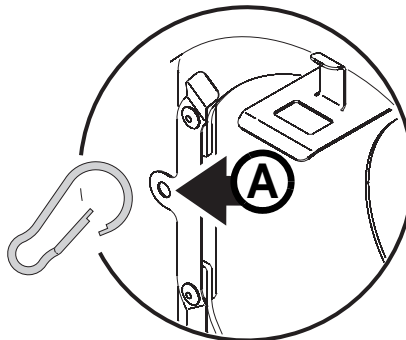

Figure 8

12. See Figure 9. Clip the new front lens assembly securely onto its mounting bracket in the front of the head.

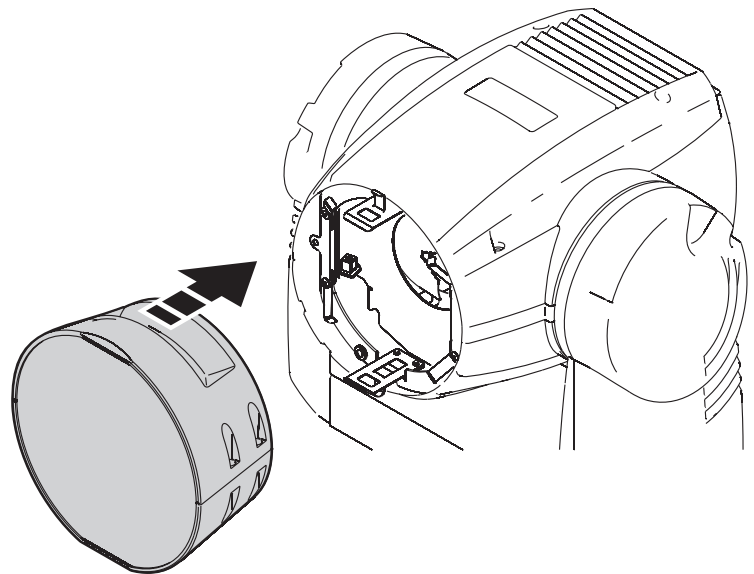

Figure 9

13. Stick the warning label supplied in the Kit onto the back of the head as shown in Figure 10. With the Beam Kit installed, this label replaces the warning printed on the standard MAC 250 Wash. **Do not illuminate any surface within 3.5 m (11 ft. 6 ins.) of the MAC 250 Beam. Do not allow the front lens to point at the sun.**

With MAC 250 Beam Upgrade Kit installed, minimum distance from lighted objects = (3.5 m.) (11.5 ft)
Avec le kit upgrade MAC 250 Beam installé, distance minimum de projection = (3.5 m.) (11.5 ft.)

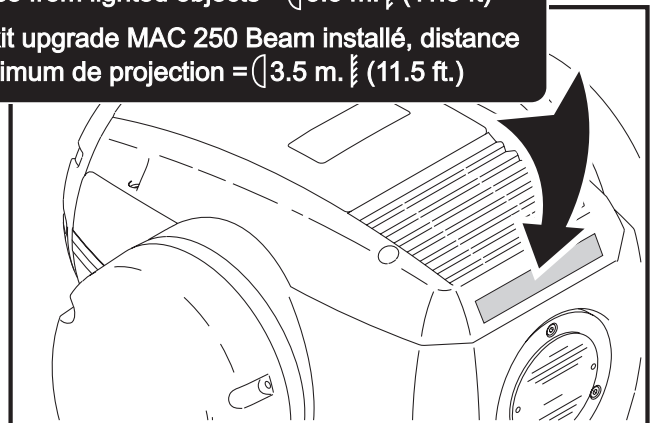
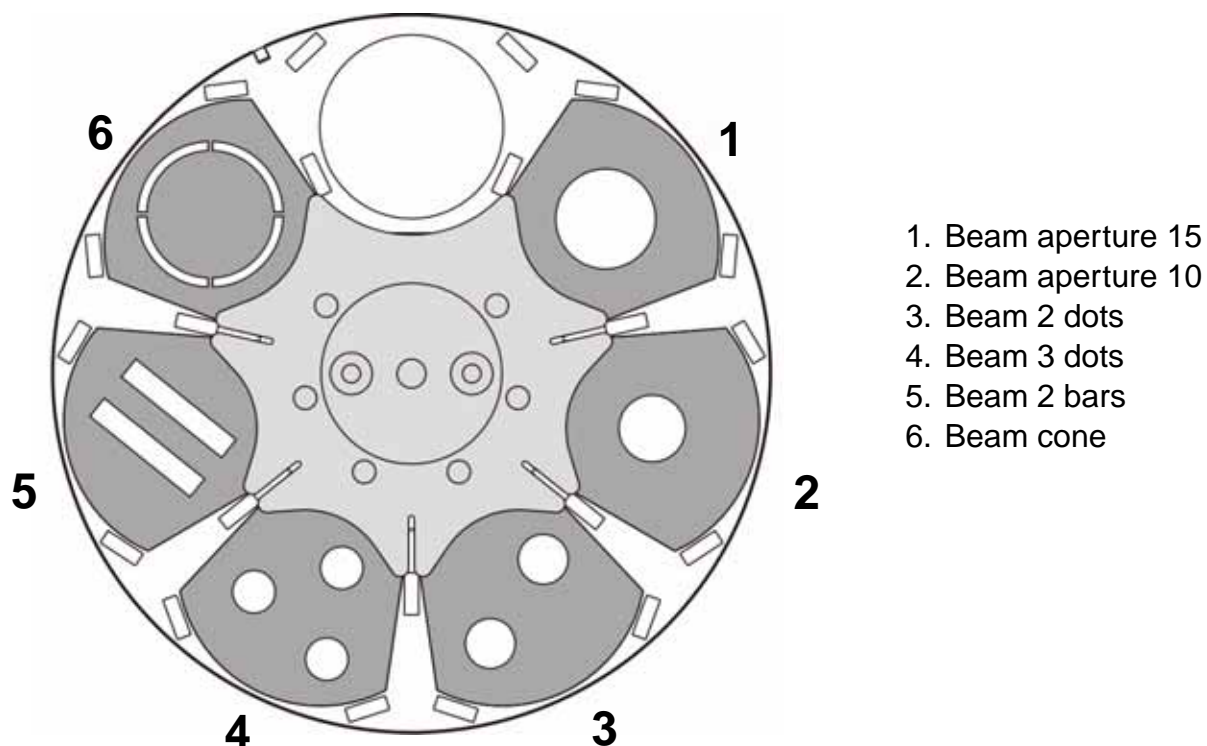

Figure 10

14. Finally, before using the fixture, update the fixture software to version 1.4.0 or later, following the software update instructions in the MAC 250 Wash user manual. From software v.1.4.0, the frost filter is moved very slightly forward in order to reduce reflections from the CMY flags. There is no need to roll back the software to an earlier version than v.1.4.0 if the fixture is returned to a standard MAC 250 Wash configuration at a future time.

The front lens assembly must be unclipped and removed from the head when the fixture is packed in a MAC 250 flightcase. We recommend that you re-use the assembly's protective packaging supplied in the MAC 250 Beam Kit and store the assembly in the tray in the flightcase.

Appendix A: MAC 250 Beam recommended gobo positions



The color/gobo wheel is shown as seen from the lamp side.

The earliest MAC 250 Beam Kits were supplied with a print version of this installation guide that showed the gobos in the reverse order. This inconsistency can be fixed at the lighting desk, but if you have a fixture with gobos reversed, we recommend that you move gobos to the positions shown above (and update any cues affected at the lighting desk) at some convenient time.

Appendix B: Changes in control

Control menu

When the MAC 250 Beam Kit is installed, the control menu commands *HEAD* → *COL* → *COL 1 - COL 6* now manually select the beam effect gobos shown on the previous page rather than color filters.

DMX

DMX Channel 6 (in 16-bit mode) or 10 (in 16-bit extended mode) now controls beam effect gobos as shown below:

6	10	0	0	Beam gobo wheel scrolling and rotation, random CMY Continuous scrolling (split gobos) Open Open → Beam aperture 15 Beam aperture 15 → Beam aperture 10 Beam aperture 10 → Beam two dots Beam two dots → Beam three dots Beam three dots → Beam two bars Beam two bars → Beam cone Beam cone → Open Stepped scrolling (full gobos) Beam cone Beam two bars Beam three dots Beam two dots Beam aperture 10 Beam aperture 15 Open Continuous rotation Clockwise, fast → slow Counterclockwise, slow → fast Random CMY color (set min. & max. CMY levels on channels 3, 4 & 5 in 16-bit and channels 4, 6 & 8 in 16-bit ex. modes) Fast Medium Slow
		1 - 26	0 - 10	
		27 - 51	11 - 20	
		52 - 77	21 - 30	
		78 - 102	31 - 40	
		103 - 128	41 - 50	
		129 - 152	51 - 60	
		153 - 179	61 - 70	
		180 - 183	71 - 72	
		184 - 187	72 - 73	
188 - 191	74 - 75			
192 - 195	75 - 76			
196 - 199	77 - 78			
200 - 203	78 - 79			
204 - 207	80 - 81			
208 - 226	82 - 88			
227 - 245	89 - 96			
246 - 248	97			
249 - 251	98			
252 - 255	99 - 100			



Martin Professional A/S • Olof Palmes Allé 18 • 8200 Aarhus N • Denmark
Tel: +45 8740 0000 • Fax +45 8740 0010 • www.martin.com