



MAXXYZ™ MODULES USER MANUAL

Martin

©2009 Martin Professional A/S. Information subject to change without notice. Martin Professional A/S and all affiliated companies disclaim liability for any injury, damage, direct or indirect loss, consequential or economic loss or any other loss occasioned by the use of, inability to use or reliance on the information contained in this manual. The Martin logo, the Martin name and all other trademarks in this document pertaining to services or products by Martin Professional A/S or its affiliates and subsidiaries are trademarks owned or licensed by Martin Professional A/S or its affiliates or subsidiaries.

P/N 35000223, Rev. A

Table of Contents

- 1. Introduction..... 5
 - 1.1 Technical support 5
 - 1.2 Safety information 5
 - 1.3 Connecting to power 6
 - 1.4 Included items..... 6
- 2. Setup and Assembly..... 7
 - 2.1 Single 'stand-alone' Maxxyz Module..... 7
 - 2.2 Mounting in a Maxxyz Module Frame 7
 - Installing a module in the lower opening of the Frame 7
 - Installing a module in the upper opening of the Frame..... 9
 - 2.3 Notes12
- 3. Daisy-chaining modules13
- 4. Connections and configuration14
 - 4.1 Cerebrum Module connections panel14
 - 4.2 Programmer, Submaster, Playback, Button connections panel15
 - 4.3 Connections.....16
 - 4.4 Configuration16
 - 4.5 Software.....16
 - 4.6 Controls16
- 5. Service17
 - 5.1 Cleaning.....17
- 6. Specifications18

1. Introduction

Thank you for selecting a product from the Martin Professional™ Maxxyz™ Modules range.

The Maxxyz Modules are an extension to the Maxxyz™ controller, the Maxxyz Compact™ controller or the Maxxyz PC™ family.

The Maxxyz Modules concept consists of either one or two modules installed in one Module Frame.

This manual matches the functionality in Version 2.6 of the Maxxyz software. For the latest firmware and software updates, documentation and other information about this controller, see www.maxxyz.com

1.1 Technical support

For a complete list of Technical Support phone numbers, see the Martin website at <http://www.martin.com/service/hotline.asp>

1.2 Safety information

This product is for professional use only. It is not for household use. It presents risks of lethal or severe injury due to electric shock. **Read this user manual** before powering or installing the Modules, follow the safety precautions listed below and observe all warnings in this manual and printed on the product

If you have questions about how to operate the product safely, please contact your Martin supplier or call the Martin 24-hour service hotline on +45 8740 0000, or in the USA on 1-888-tech-180.

- Connect the product electrically to ground (earth).
- Use only a source of AC power that complies with local building and electrical codes and has both overload and ground-fault protection.
- Replace fuses with ones of the same type and rating only. Never attempt to bypass a fuse.
- Disconnect the product from power immediately if the power cable or any cover or component is wet or not in perfect condition. Do not reconnect to power until the damaged item has been repaired or replaced.
- Do not expose the product to rain or moisture.
- Allow free unobstructed airflow to the front and the back of the product.
- Do not use the product if the ambient temperature exceeds 40°C (104° F)
- Refer any service operation not described in this manual to a qualified technician.
- Do not modify the product or install other than genuine Martin parts.

- Before transportation, secure modules in place in a frame with the supplied screws.

1.3 Connecting to power

Maxxyz Modules automatically adapt to AC mains power at 100-240 V nominal, 50/60 Hz. Do not connect them to power outside this range.

You may need to install a cord cap that fits your supply on the power cable. A 3-prong grounding-type plug must be installed following the plug manufacturer's instructions. The table below shows some possible pin identification schemes; if the pins are not clearly identified, or if you have any doubts about proper installation, consult a qualified electrician.

| Wire color (standard EU code) | Pin | Symbol |
|-------------------------------|---------|---|
| brown | live | L |
| blue | neutral | N |
| yellow/green | ground |  |

1.4 Included items

Each Maxxyz Module, part numbers 90732140 (Cerebrum), 90732150 (Programmer), 90732160 (Button), 90732170 (Submaster) and 90732180 (Playback), contains the following items:

- Maxxyz Module
- Two 2 AT fuses, installed
- IEC Power cable (part number 11501012)
- Ethercon Network cable (part number 11840144)
- USB cable (part number 11840066)
- User manual (part number 35000223)

Each Module Frame, part number 90732120 (shipped in flightcase) and 90732130 (shipped in cardboard box) contains the following items:

- Module Frame with attached Ethercon Power interconnect cables and desklight cable
- Desk lamp (built in)
- Blind cover plate (installed)
- Dust cover

2. Setup and Assembly

There are two different methods of setting up the Maxxyz Modules: one for “stand-alone” use and one for mounting in a Maxxyz Module Frame.

2.1 Single ‘stand-alone’ Maxxyz Module

Each module is shipped with protective foam attached to each side. This foam supports the faceplate and prevents cosmetic damage to the module. Apart from connection to the controller, the module is “ready to use” as soon as it is removed from its packaging.

2.2 Mounting in a Maxxyz Module Frame

Installing a module in the lower opening of the Frame

1. Remove the module(s) and the module frame from their packing material.
2. Use a 3 mm Allen wrench to remove the two screws that attach the side strips to each side of the module opening in the frame.

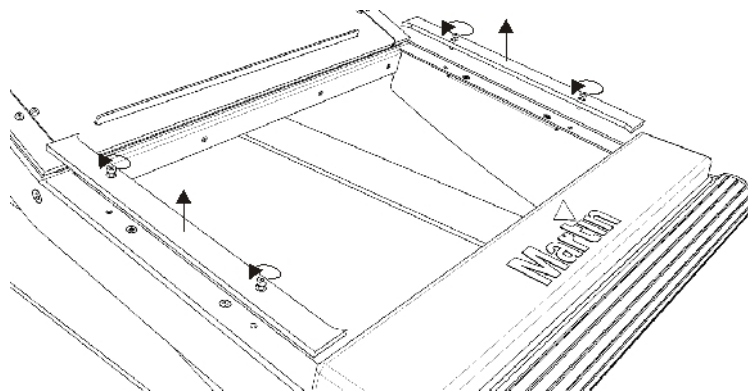

3. The module can now be placed in the lower opening. Put the side strips back on each side of the module and fasten them in place with their screws.

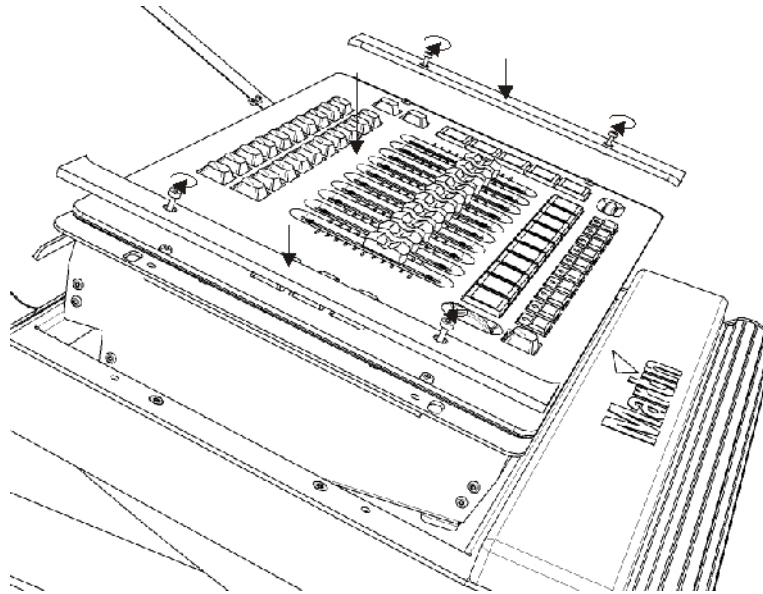

Important! The Cerebrum Module only fits in the upper opening of the Maxxyz Module Frame.

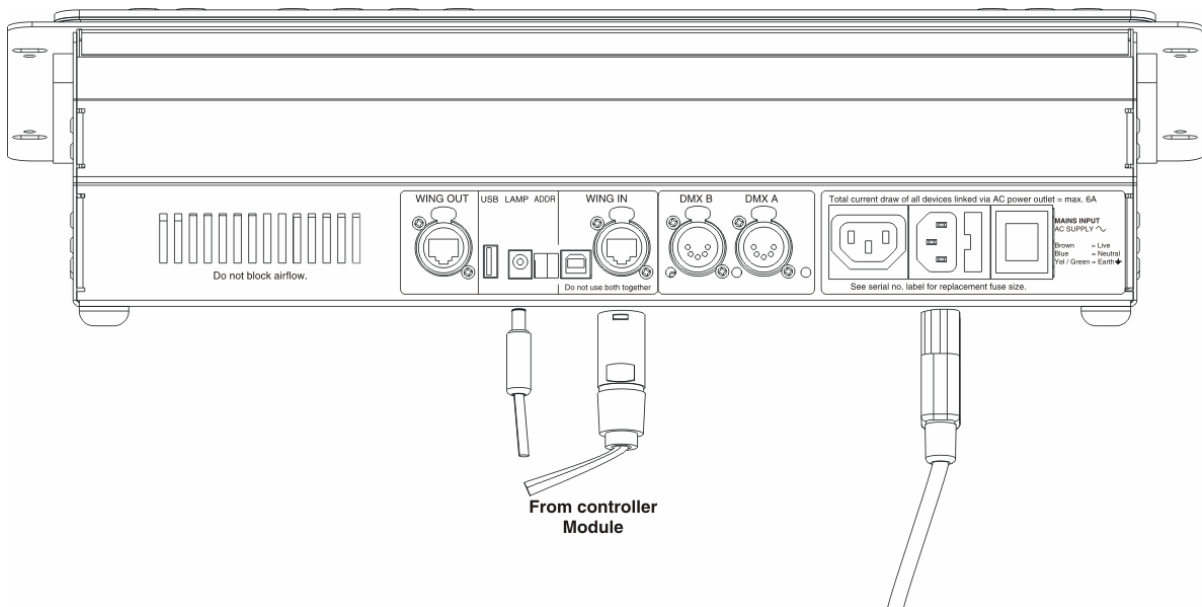

4. Connect the Power interconnect cable to the **MAINS IN** connector, or, if only one module is used, connect the IEC Power cable (*part number 11501012*) to the **MAINS IN** connector.

5. Connect the EtherCon interconnect cable to the **WING IN** connector, or, if only one module is used, connect the EtherCon Network cable (*part number 11840144*) to the **WING IN** connector.
6. Connect the Lamp bayonet plug to the “**LAMP**” connector. This will connect the top illumination to the module.

Installing a module in the upper opening of the Frame

Cerebrum module

1. Use a 3 mm Allen wrench to remove the four screws that attach the blind cover plate (if installed) to the frame.

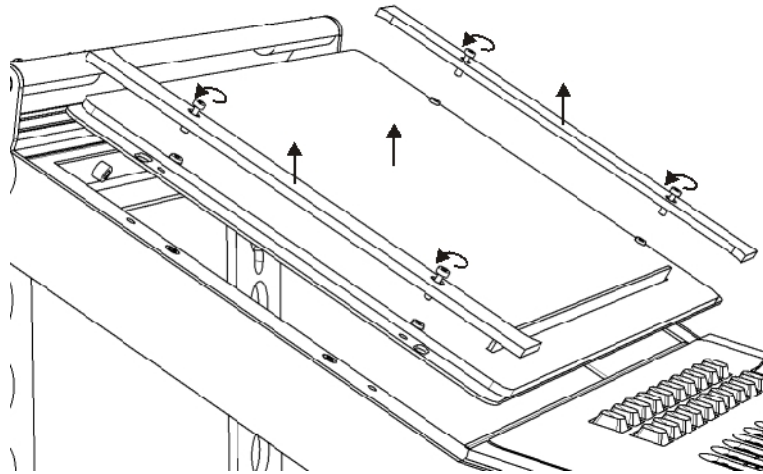

2. The Cerebrum Module can now be placed into the top opening. Put the side strips back on each side of the frame and fasten them in place with their screws.

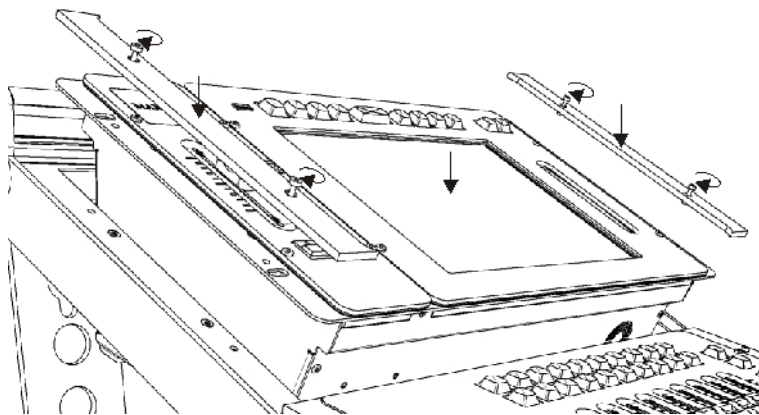

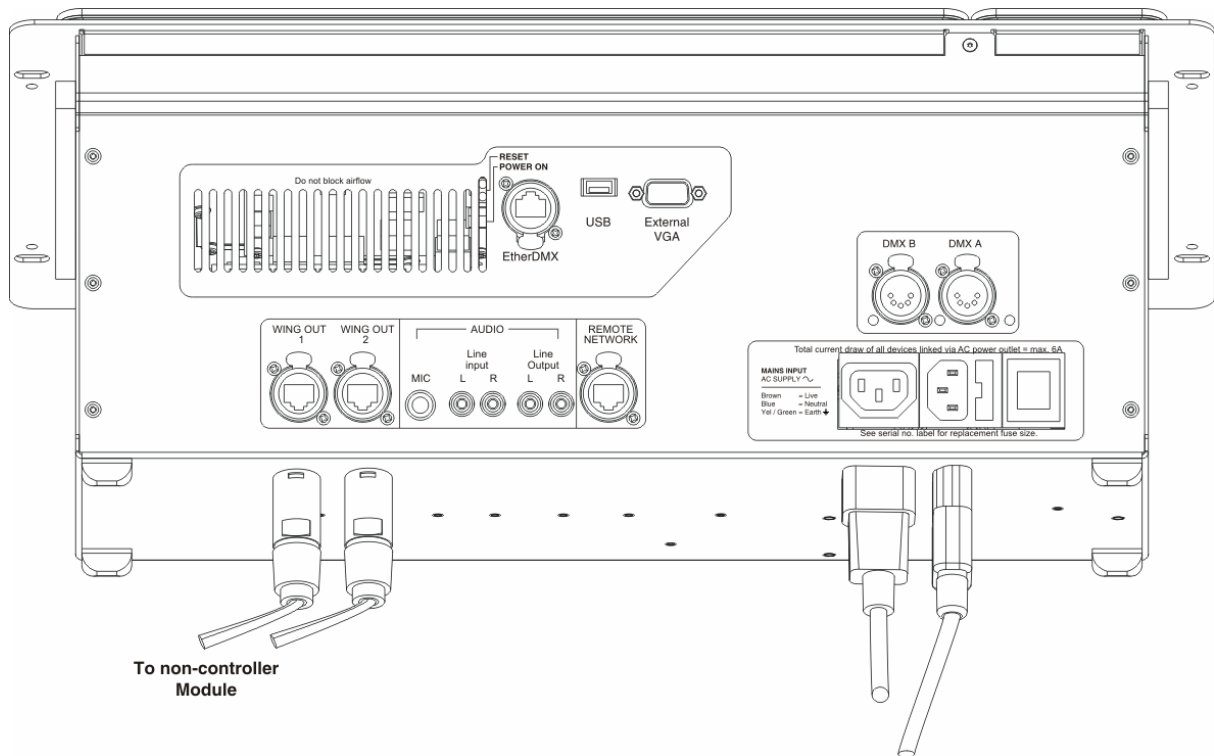

3. Connect the Power interconnect cable to the **MAINS OUT** connector.
4. Connect the EtherCon Network cable (*part number 11840144*) to the **WING OUT** connector.
5. Connect the IEC Power cable (*part number 11501012*) to the **MAINS IN** connector.



Important! The Cerebrum Module is a controller module and must not be connected to a Maxxyz controller, a Maxxyz Compact controller, a Maxxyz PC or another Cerebrum using the WING OUT outputs. The WING OUT outputs must only used to connect non-controller modules (Programmer, Button, Submaster and Playback Modules) to the Cerebrum.

Non-controller modules (i.e. not Cerebrum module)

1. Use a 3 mm Allen wrench to remove the four screws that attach the blind cover plate (if installed) to the frame.

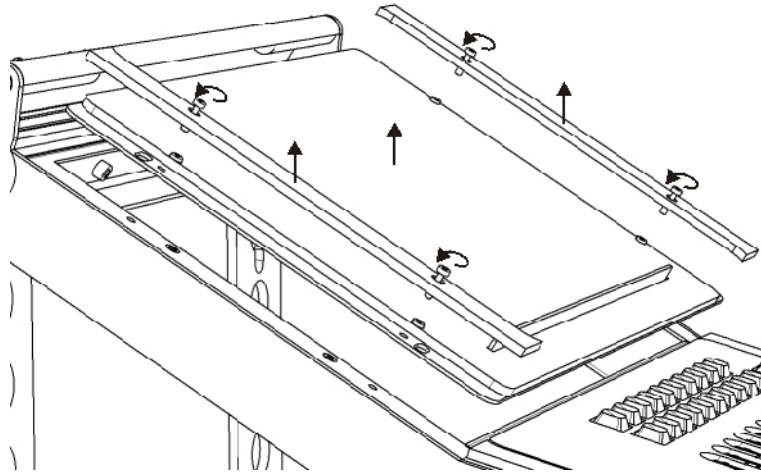

2. The module can now be placed in the top opening. Put the side strips back on each side of the frame and fasten them in place with their screws.

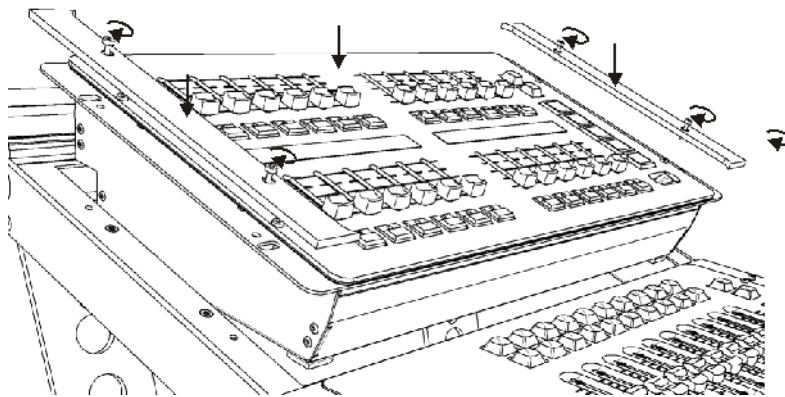

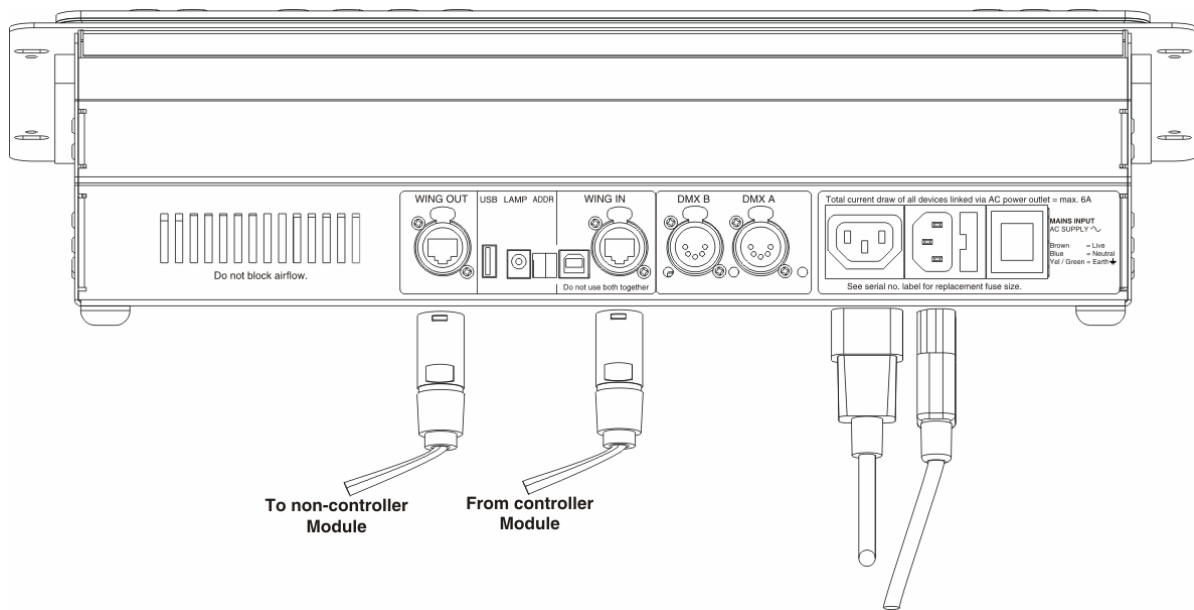

3. Connect the Power interconnect cable to the **MAINS OUT** connector.
4. Connect the EtherCon Network cable (*part number 11840144*) to the **WING OUT** connector.
5. Connect the IEC Power cable (*part number 11501012*) to the **MAINS IN** connector.
6. Connect the EtherCon Network cable (*part number 11840144*) to the **WING IN** connector.

2.3 Notes

If the top module is not powered, the bottom module will not be able to communicate with the controller it is connected to.

The power switch is hidden behind the leg (if you stand in front of the controller, the switch can be found on the left-hand side).

The modules (but **NOT** the Cerebrum module, *part number 90732140*) can also be connected directly to a laptop or PC using a USB cable.

A non-controller module means a Playback, Submaster, Programmer or Button module.

A controller module means a Cerebrum module or a Wing OUT connection of a non-controller module, but can also be a Maxxyz, Maxxyz Compact or Maxxyz PC.



Important! Do not use both WING IN connections, USB and XLR, at the same time.

The modules can also be used in combination with older playback modules. The older modules, however, do not fit in the new frame.

3. Daisy-chaining modules

Modules can be daisy-chained to a maximum of 4 modules deep. Each module has 2 outputs to daisy-chain to the next module(s): the Wing out and USB connections. Each Maxxyz Wing module uses some USB bandwidth (the amount depends on the Wing type being used), therefore it is possible that some modules will not be recognized if too many Wing modules are connected to a controller module.

Do not daisy-chain more than 4 modules deep. If the setup is 5 modules deep, the fifth module will not be recognized.

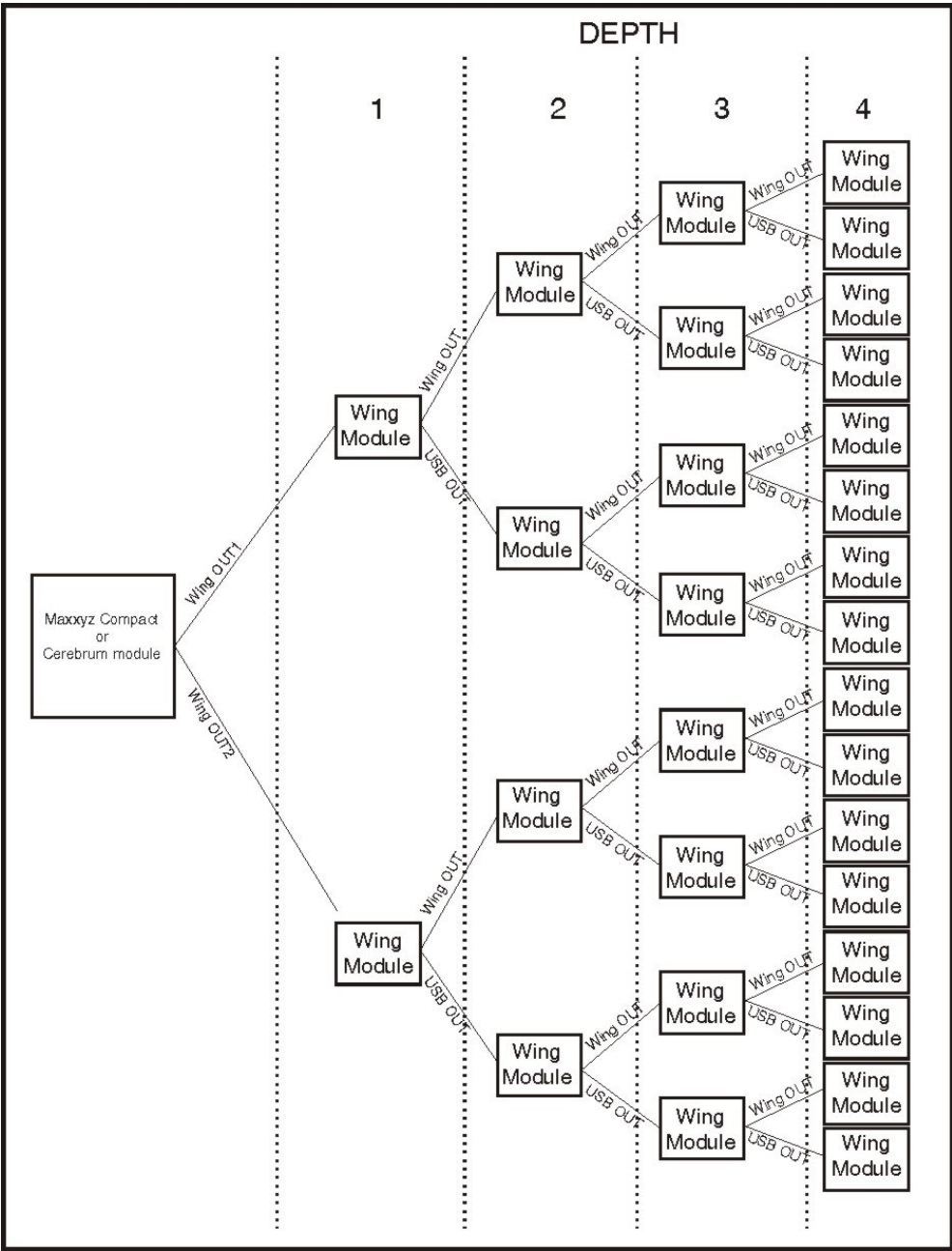

4. Connections and configuration

4.1 Cerebrum Module connections panel

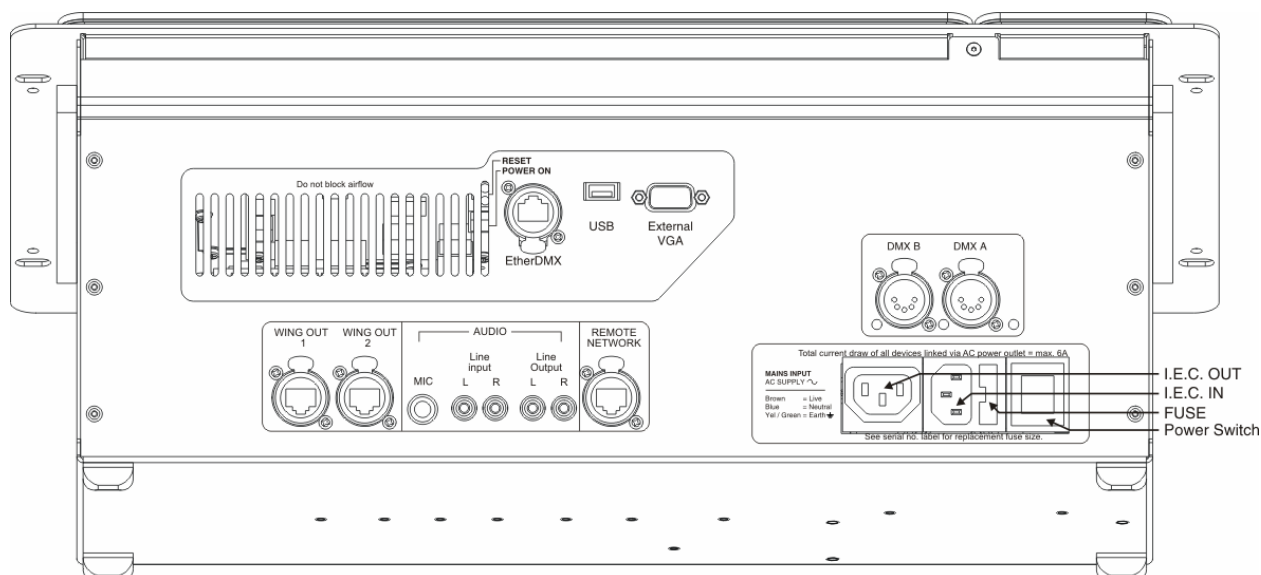

| | |
|---------------------------|---|
| RESET | Use a ballpoint pen or pencil to press this switch. Activating the switch causes a hardware reset. |
| POWER ON | Use a ballpoint pen or pencil to press this switch. Activating the switch is needed if the module refuses to start when power is applied to the module and the Power Switch is set to ON |
| EtherDMX | Artnet-compatible network XLR |
| USB | USB device socket |
| External VGA | External monitor connector |
| DMX A, DMX B | DMX outputs (RDM-ready) |
| WING OUT 1, WING OUT 2 | Wing output RJ45 in XLR-type housing. Important! Connect only other non-controller modules (Programmer, Submaster, Playback or Button Modules) to these outputs. Never use this output to connect to a Maxxyz, Maxxyz Compact, Maxxyz PC or another Cerebrum module. |
| MIC | Audio microphone input |
| Line input | Stereo line-level audio inputs, left and right |
| Line output | Stereo line-level audio outputs, left and right |
| REMOTE NETWORK | MaxNet controller network RJ45 in XLR-type housing |

| | |
|--------------|---|
| IEC OUT | AC output, unswitched, unfused. Warning! Do not draw a current of more than 6 A total from this output |
| IEC IN | AC mains power input, accepts 100-240 V nominal, 50/60 Hz |
| FUSE | Fuse holder, two 2 AT (slow blow) fuses |
| Power Switch | Power on/off |

4.2 Programmer, Submaster, Playback, Button connections panel

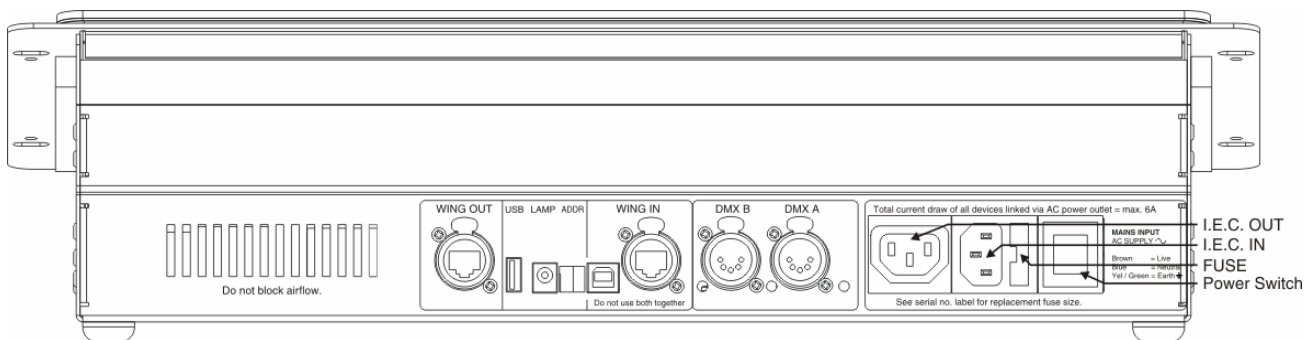

| | |
|--------------|--|
| WING OUT | Wing output RJ45 in XLR-type housing. Important! Connect only other non-controller modules (Programmer, Submaster, Playback or Button Modules) to this output. Never use this output to connect to a Maxxyz, Maxxyz Compact, Maxxyz PC or Cerebrum module. |
| USB | USB device socket |
| LAMP | 12 V PWM controlled lamp output |
| ADDR | Rotary dipswitch, 0 to F selectable |
| WING IN | Wing input (USB and RJ45 in XLR-type housing). Use only one of these sockets at any one time to connect the module to a Maxxyz controller, Maxxyz Compact controller, Cerebrum module or Maxxyz PC. Important! Never use the USB and RJ45 sockets at the same time. |
| DMX A, DMX B | DMX outputs (RD-ready) |
| IEC OUT | AC output, unswitched, unfused. Warning! Do not draw a current of more than 6 A total from this output |
| IEC IN | AC mains power input, accepts 100-240 V nominal, 50/60 Hz |
| FUSE | Fuse holder, two 2 AT (slow blow) fuses |
| Power Switch | Power on/off |

4.3 Connections

Connections to a Maxxyz controller, a Maxxyz Compact controller or a Maxxyz PC for either an individual Maxxyz Module or a frame with modules are simple and similar.

1. Connect an EtherCon Network cable (*part number 11840144*) to the “**WING IN**” connector on the back of the module. If you are using the frame, use the “**WING IN**” connector on the top module.



Important! Never use a WING OUT connection to connect a module to a Maxxyz controller, a Maxxyz Compact controller, a Maxxyz PC or a Cerebrum module.

2. Connect the other end of the EtherCon Network cable (*part number 11840144*) to either “**WING 1**”, “**WING 2**”, “**WING 3**” or “**WING 4**” connector on the back of the Maxxyz controller or the Maxxyz Compact controller. It doesn’t matter which connector you use.
3. Connect the IEC Power cable (*part number 11501012*) to the “**MAINS IN**” connector on the back of the module and plug the other end of the IEC Power cable (*part number 11501012*) to your mains power supply. If you are using the frame, use the “**MAINS IN**” on the top module (if installed).

While it is possible to use the frame standing separately from the Maxxyz controller, Maxxyz Compact controller or the Maxxyz PC controller, it is also possible to connect the frame directly to any of these devices.

4.4 Configuration

It is possible to connect up to sixteen (16) modules (or eight fully populated Maxxyz Module Frames) to a Maxxyz controller, a Maxxyz Compact controller or a Maxxyz PC controller. No more than four modules may be connected to any given “WING” connector found on the back of the controller and every module must have a unique ID (0, 1, 2, 3, 4, 5, 6, 7, 8, 9, A, B, C, D, E, F). These IDs are set using the rotary DIP switch found on the back of the module.

4.5 Software

The modules require connection to a Maxxyz controller running Version 2.6 or higher.

4.6 Controls

Most of the functionality of the Maxxyz Modules is covered in the Martin Maxxyz User Manual.

5. Service

The Maxxyz Modules are designed as rugged, roadworthy devices. Occasional cleaning is the only service required of the user. For any other service-related concerns, please contact your Martin dealer or visit www.martin.com.

Any service not described in this User Manual must be carried out by a qualified Martin technician.

5.1 Cleaning

The Maxxyz Modules require periodic cleaning, as does any computer. The schedule depends heavily on the operating environment; please consult a Martin service technician for recommendations if needed.

As with any computer, never spray the cleaner directly onto the module, always spray onto a lint-free cloth and wipe clean.



Important! Excessive dust and smoke fluid build-up can degrade performance and cause overheating and damage to the module that is not covered by the warranty.

6. Specifications

Physical

Cerebrum Module

| | |
|--------------|--------------------|
| Length | 275 mm (10.9 in.) |
| Width | 483 mm (19 in.) |
| Height | 182 mm (7.2 in.) |
| Weight | 7.3 kg (16.1 lbs.) |

Playback Module

| | |
|--------------|--------------------|
| Length | 275 mm (10.9 in.) |
| Width | 483 mm (19 in.) |
| Height | 128 mm (5 in.) |
| Weight | 5.7 kg (12.6 lbs.) |

Submaster Module

| | |
|--------------|--------------------|
| Length | 275 mm (10.9 in.) |
| Width | 483 mm (19 in.) |
| Height | 128 mm (5 in.) |
| Weight | 4.6 kg (10.2 lbs.) |

Button Module

| | |
|--------------|--------------------|
| Length | 275 mm (10.9 in.) |
| Width | 483 mm (19 in.) |
| Height | 128 mm (5 in.) |
| Weight | 5.2 kg (11.5 lbs.) |

Programmer Module

| | |
|--------------|--------------------|
| Length | 275 mm (10.9 in.) |
| Width | 483 mm (19 in.) |
| Height | 128 mm (5 in.) |
| Weight | 5.0 kg (11.3 lbs.) |

Frame without modules

| | |
|--------------|---------------------|
| Length | 695 mm (27.3 in.) |
| Width | 526 mm (20.7 in.) |
| Height | 336 mm (13.21 in.) |
| Weight | 10.3 kg (22.7 lbs.) |

Connections

Cerebrum Module

| | |
|-----------------------------|--|
| AC Power input..... | 3-pin IEC male socket |
| AC Power output | 3-pin IEC female socket |
| LINK USB data outputs | Neutrik RJ-45 socket (accepts Neutrik EtherCon connectors in housing) |
| Network data | Neutrik RJ-45 socket (accepts Neutrik |

| | |
|---------------------|---------------------------------------|
| | EtherCon connectors in housing) |
| EtherDMX data | Neutrik RJ-45 socket (accepts Neutrik |
| | EtherCon connectors in housing) |
| DMX data..... | 5-pin locking XLR |
| USB devices..... | USB host socket |
| Microphone..... | 6.3 mm mono socket |
| Audio in/out..... | RCA phono |
| VGA..... | 15-pin D-sub female |

Other modules (not Cerebrum)

| | |
|----------------------------|--|
| AC Power input..... | I.E.C. male socket |
| AC Power output | I.E.C. female socket |
| LINK USB data output | Neutrik RJ-45 socket (accepts Neutrik |
| | EtherCon connectors in housing) |
| LINK USB data input | Neutrik RJ-45 socket (accepts Neutrik |
| | EtherCon connectors in housing) |
| DMX data..... | 5-pin locking XLR |
| USB devices..... | USB host socket |
| USB input | USB device socket |
| LAMP output..... | 2.5 mm DC bayonet socket |
| | (also accepts 2.5 mm DC plugs without bayonet) |

Electrical (all modules)

| | |
|-------------------------------------|-------------------------------|
| AC power..... | 100-240 V nominal, 50/60 Hz |
| Power supply unit | Full range switch-mode |
| Main fuses | 2 AT (x2) |
| AC power throughput..... | unswitched, unfused, Max. 6 A |
| Lamp output (not on Cerebrum) | 12 V PWM |

Functional

Cerebrum Module

- Grand master fader and button
- Flash master fader and button
- 16 x view buttons, 2 x view scroll buttons
- Digital encoder wheels for window scrolling and screen/desk lamp intensity
- Protocol: DMX512, Artnet (ACN and RDM pending)
- 2 DMX universes, expandable to 32
- 1024 channels, expandable to 16384
- No limit to number of DMX channels per fixture
- Extensive fixture library for all known manufacturers
- 65000 presets for each group of functions (P/T, color, gobo, etc.)
- Effect generator for automated programming of complex effects
- Customizable highlight and lowlight function to identify individual fixtures
- Relative or absolute programming

- Fan function for all channels (including timing parameters)
- On-the-fly global timing changes
- Virtual cuelists
- Macros
- Wait, follow and link cues
- HTP, LTP, chase, timecode, submaster and group master playback functionality
- Individual parameter timings
- Intuitive patch feature
- Fixture type cloning
- Full 16-bit fading for high-resolution fixtures
- Individual fade in/fade out times for all playbacks
- Manual override available at all times
- Live 0-1000% override of global cue timings
- Live programmer timing (“Sneak”)
- Go-function (supports multiple cues simultaneously)
- Cuelists can be executed in tracking or non-tracking mode

Playback Module

- 10 x motorized playback faders, each with one dynamically labeled LCD button (to identify/activate playback) and two function-assignable buttons
- 10 x pause/back buttons
- 10 x go buttons
- 10 x flash buttons
- 5 x LCD navigation buttons with scroll wheel
- Master GO section

Submaster Module

- 24 x non-motorized faders with single function button (every supported cuelist type is supported)
- 40-character display for labeling
- 5 x LCD navigation buttons with scroll wheel

Button Module

- 3 rows of 10 x LCD and function button combination
- 5 x LCD navigation buttons with scroll wheel
- Digital fader belt for intensity, speed and timing controls
- Mode buttons for selecting desired operation per row. Supported modes are:
 - Fixture Selection
 - Group Selection
 - Preset Selection
 - Playback Buttons

Programmer Module

- 4 x digital fader belts for fixture parameter control
- Trackball with pan/tilt control switch

- Blind/preview button
- Customizable highlight/lowlight function
- Next/last fixtures/groups
- Left/right mouse button
- Customizable LCD function keys for function shortcuts

Frame without modules

- Blind cover plate with paper holder
- Accepts two Maxxyz Modules (Cerebrum can be installed in upper position only)
- Dimmable LED strip (requires Module to be installed)

Accessories

| | |
|--|----------------------------|
| Blind cover plate for Maxxyz Frame Module | P/N 62406159 |
| Maxxyz Modules dust cover | P/N 33302009 |
| Maxxyz Compact monitor bracket, left | P/N 55732076 |
| Maxxyz Compact monitor bracket, right | P/N 55732074 |
| Four 3-pin female to 5-pin male XLR adapters..... | P/N 91613024 |
| 1.5 m power cable, 3-pin IEC | P/N 11501012 |
| EtherCon patch cable, 2 m, RJ-45 in XLR-type housing | P/N 11840144 |
| Flightcase for Maxxyz Modules Frame | P/N 91535007 |
| Wheel set for Maxxyz Modules flight case | Contact Martin for details |

Ordering Information

| | |
|--|--------------|
| MaxModule Cerebrum | P/N 90732140 |
| MaxModule Button..... | P/N 90732160 |
| MaxModule Playback | P/N 90732180 |
| MaxModule Programmer | P/N 90732150 |
| MaxModule Submaster..... | P/N 90732170 |
| MaxModule Frame (empty) in Flightcase | P/N 90732120 |
| MaxModule Frame (empty) in Cardboard Box | P/N 90732130 |

Specifications subject to change without notice.

See www.martin.com for current user documentation, technical support and full current product specifications.



Martin Professional A/S ● Olof Palmes Allé 18 ● 8200 Aarhus N ● Denmark
<http://www.martin.com>