

# Exterior Linear Series

*Exterior Linear Cove*  
*Exterior Linear Graze*

**User manual**

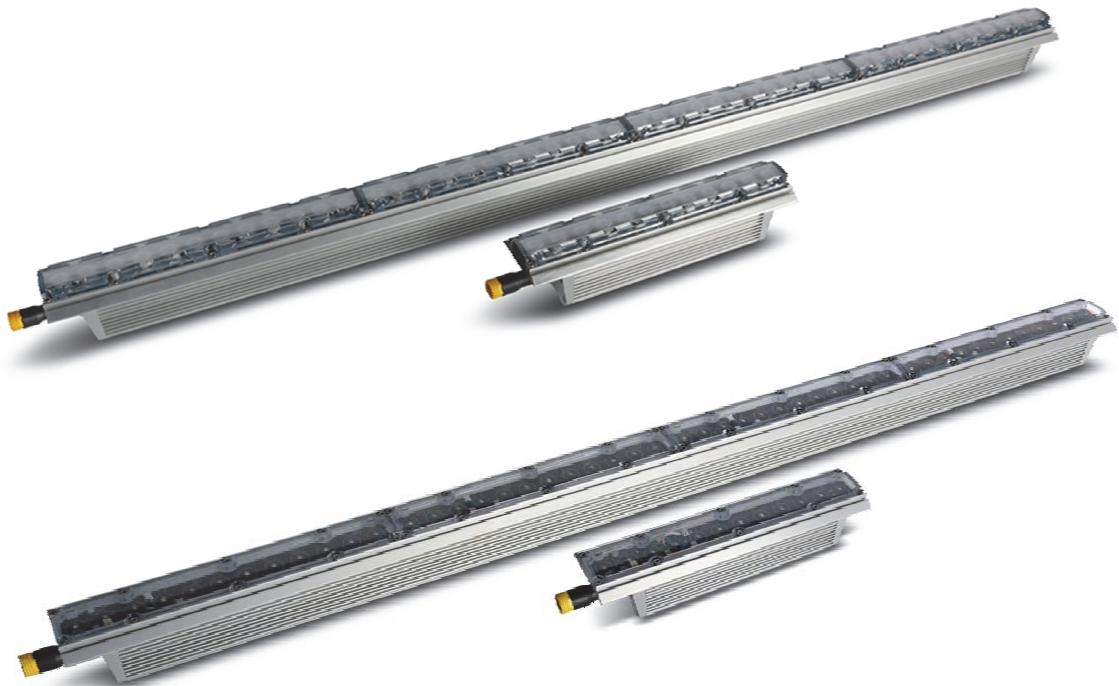

**Martin**<sup>®</sup>  
by HARMAN

# Dimensions

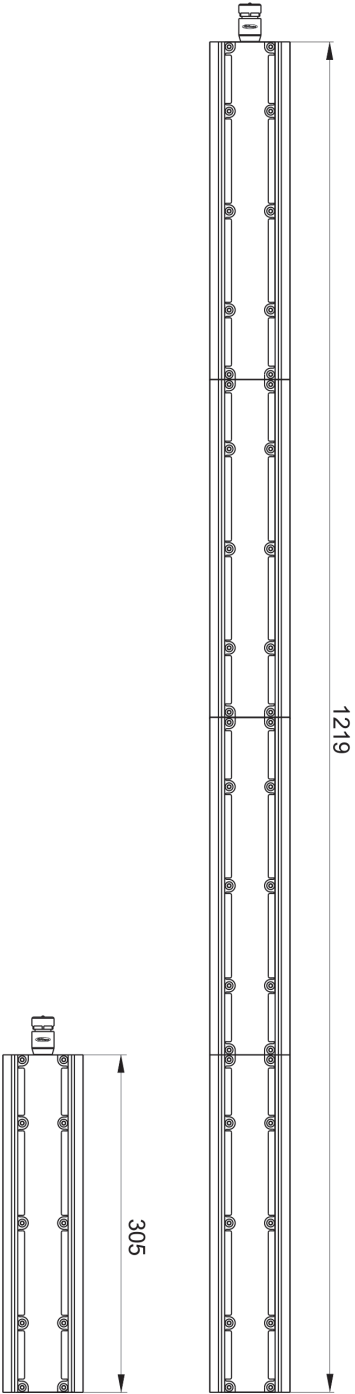
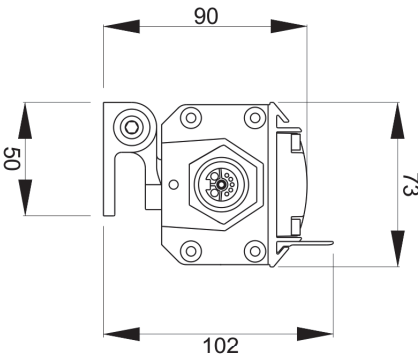
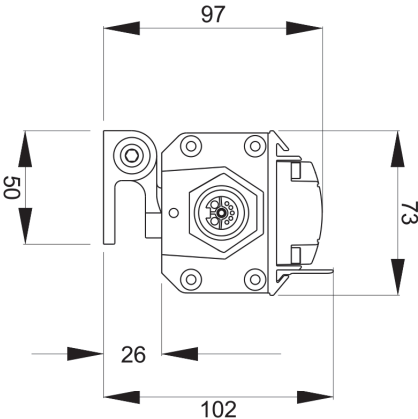

All dimensions are given in millimeters  
 For mounting bracket dimensions see page 8

© 2016 Martin Professional™ ApS. Information subject to change without notice. Martin Professional™ and all affiliated companies disclaim liability for any injury, damage, direct or indirect loss, consequential or economic loss or any other loss occasioned by the use of, inability to use or reliance on the information contained in this manual. Martin™, Harman™ and all other trademarks in this document pertaining to services or products by Martin Professional™ or its affiliates and subsidiaries are registered as the property of Harman International Industries.

# Table of contents

Dimensions .....	2
Safety information .....	4
Introduction .....	6
Before using the product for the first time .....	6
Fixture overview .....	7
Physical installation .....	8
Fixture location .....	8
Mounting the fixture .....	8
Installing a Glare Shield .....	10
AC power and data connection .....	11
Power requirements .....	11
Data network requirements .....	13
Connecting power and data .....	13
Setup .....	15
RDM and Martin™ M-PC .....	15
Step one: scanning for devices on the data link .....	15
Setting up DMX behavior .....	15
Dimming control .....	16
Refresh rate control .....	16
Temperature, current draw and refresh rate status .....	17
Overall fixture status .....	17
RDM .....	18
Maintenance .....	19
Running test sequences .....	19
Managing humidity .....	20
Cleaning .....	21
DMX protocol .....	22
Exterior Linear Series 300 & 1200 RGBW models .....	22
Exterior Linear Series 320 & 1220 variable white models .....	22
Specifications .....	24

# Safety information



## WARNING!

Read the safety precautions in this manual before installing, operating or servicing this product.

The following symbols are used to identify important safety information on the product and in this manual:



**Warning!**

**Safety hazard. Risk of severe injury or death.**



**Warning!**

**Powerful light emission. Risk of eye injury.**



**Warning!**

**See user manual for important safety information.**



**Warning!**

**Hazardous voltage. Risk of lethal or severe electric shock.**



**Warning!**

**Fire hazard.**



**Warning!**

**Hot surfaces.**



Warning! Risk Group 1 product according to EN 62471. Do not stare directly into the beam. Do not view the light output with optical instruments or any device that may concentrate the beam.

This lighting fixture is for professional use only and must be installed by a qualified technician. It is not for household use. It presents risks of severe injury or death due to fire hazards, electric shock and falls. It can create a fire hazard or a risk of eye injury if the safety precautions below are not followed.



Install, operate and service Martin™ products only as directed in their user manuals, or you may create a safety hazard or cause damage that is not covered by product warranties. Follow the safety precautions listed below and observe all warnings in this manual and printed on the product. Keep this user manual for future use.

For the latest user documentation and other information about this and all Martin™ products, please visit the Martin website at <http://www.martin.com>

If you have any questions about how to install, operate or service the fixture safely, please contact your Martin™ distributor (see [www.martin.com/distributors](http://www.martin.com/distributors) for details) or call the Martin™ 24-hour service hotline on +45 8740 0000, or in the USA on 1-888-tech-180.

Respect all locally applicable laws, codes and regulations when installing, operating or servicing the fixture.



### Protection from electric shock

Ensure that the fixture is electrically connected to ground (earth).

Disconnect the fixture from AC power when not in use.

Never connect or disconnect a live Power + Data Cable. Shut down power to the fixtures before connecting or disconnecting cables.

Do not open the fixture or remove any cover. Refer any service operation not described in this manual to an authorized Martin Service partner.

Shut down power to the entire installation at the main power distribution board and lock out power before carrying out any installation or maintenance work.

Use only a source of AC power that complies with local building and electrical codes and has both overload and ground-fault (earth-fault) protection.

Isolate the fixture from power immediately if any seal, cover, cable, or other component is damaged, defective, deformed or showing signs of overheating. Do not reapply power until repairs have been completed

Before using the fixture, check that all power distribution equipment and cables are in perfect condition, are rated for the current requirements of all connected devices, are protected to IP67 or higher and are of suitable type for the location (including water, pollution, temperature and UV resistance).

Do not immerse the fixture in water or any other fluid, or install it in a location where flooding may occur.



#### **Protection from burns and fire**

Do not operate the fixture if the ambient temperature ( $T_a$ ) exceeds  $45^{\circ}\text{C}$  ( $113^{\circ}\text{F}$ ).

The surface of the fixture can reach up to  $85^{\circ}\text{C}$  ( $185^{\circ}\text{F}$ ) if the fixture is operated at the maximum permitted ambient temperature. Ensure that accidental physical contact with the fixture is impossible. Allow the fixture to cool for at least 5 minutes before handling.

Install the fixture on a non-combustible surface (brick, concrete, plaster etc.) only.

Do not aim the fixture towards combustible materials (fabric, wood, paper etc.) that are within 10 cm (4 in.) of the fixture.

Keep the fixture well away from flammable materials (volatile liquids etc.).

Ensure that there is free and unobstructed airflow around the fixture.

Allow at least 0.1 m (4 in.) free space around the fixture.

Do not attempt to bypass thermostatic switches or fuses.

Do not modify the fixture in any way not described in this manual or install other than genuine Martin™ parts. Do not stick filters, masks or other materials onto any lens or other optical component. Use only accessories approved by Martin™ to modify the light beam.



#### **Protection from eye injury**

Do not look directly into the product's light output from less than 1.5 m (5 ft.).

Do not look at the light output with magnifiers, telescopes, binoculars or similar optical instruments that may concentrate the light output.



#### **Protection from injury**

Fasten the fixture securely to a fixed surface or structure when in use. The fixture is not portable when installed.

Ensure that all supporting structures, surfaces, fasteners and lifting equipment can bear the weight of all the devices they are intended to support plus an adequate safety margin, and that they conform to local building and safety regulations.

Ensure that any accessory such as a glare shield is securely fastened.

Block access below the work area and work from a stable platform whenever installing, setting, adjusting, or cleaning the fixture.

Do not operate the fixture with missing or damaged covers, shields or any optical component.

If an operating problem occurs, stop using the fixture immediately and disconnect it from power. Do not attempt to use a fixture that is obviously damaged.

# Introduction

The Exterior Linear Series from Martin™ is a line of rugged LED-based outdoor lighting fixtures. Exterior Linear fixtures are available in red-green-blue-white (RGBW) dynamic color mixing and cold-neutral-warm variable white (VW) models, and fixtures are also available in 300 mm (1 ft.) and 1200 mm (4 ft.) length models. Cove models are designed for a range of indirect lighting applications. Graze models are designed for illumination of walls or other surfaces and are available in 10°, 15°, 60° and asymmetric 10° x 60° beam-angle variants.

The fixtures are addressed via RDM and controlled by DMX. The 4 ft. versions can be operated as a single unit or in individual 1 ft. segments.

Connecting Exterior Linear Series fixtures is easy, making for simple installation of long runs.

All Exterior Linear Series fixtures feature:

- Long-life, high output 3 W CREE XP-E2 LEDs
- Functional and discreet optional glare shield
- IP66 ingress protection rating (suitable for permanent outdoor use)
- Built-in 100-277 V, 50/60 Hz auto-ranging AC power supply
- Easy wiring with combined power and data cables

Each fixture is supplied with two hinged mounting brackets.

## Before using the product for the first time

1. Read 'Safety information' on page 4 before installing, operating or servicing the fixture.
2. Unpack and ensure that there is no transportation damage before using the fixture. Do not attempt to operate a damaged fixture.
3. Before operating, ensure that the voltage and frequency of the power supply match the power requirements of the fixture.
4. If fixtures are exposed to a sudden temperature change, give them time to warm or cool to the ambient temperature before applying power. This will help avoid damage due to condensation.
5. Check the support pages on the Martin Professional website at [www.martin.com](http://www.martin.com) for the most recent user documentation and technical information about the fixture. Martin™ user manual revisions are identified by the revision letter at the bottom of the inside cover.

# Fixture overview

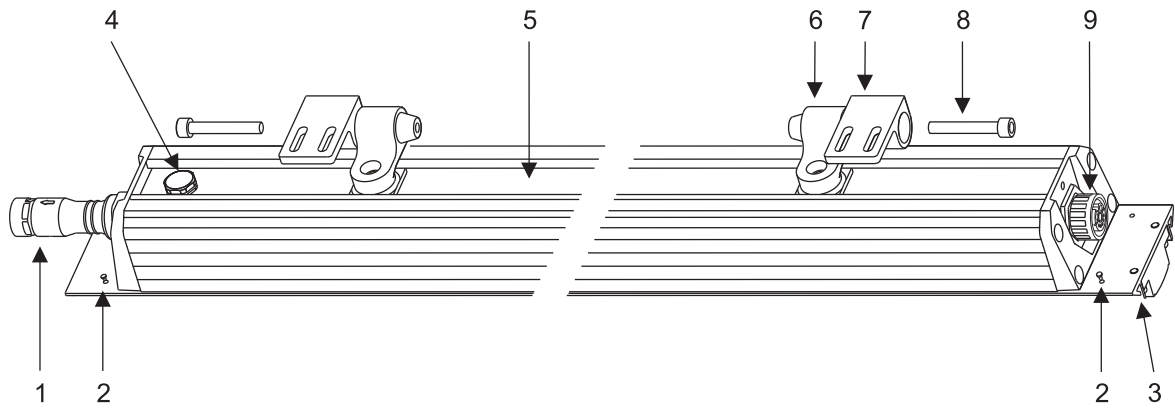

Number	Description
1	Power/data input
2	Accessory lock screw (4)
3	Accessory track (2)
4	Pressure relief valve
5	Mounting bracket track
6	Hinged mounting bracket (2)
7	Mounting flange (2)
8	Hinge bolt (2)
9	Power/data throughput

*Exterior Linear Series Parts Identification*

# Physical installation



**Warning!** Read 'Safety information' on page 4 before installing the fixture.

Warning! The safety and suitability of lifting equipment, installation location, anchoring method, mounting hardware and electrical installation are the responsibility of the installer. All local safety regulations and legal requirements must be observed when installing and connecting the Exterior Linear Series. Installation must be carried out by qualified professionals only.

Contact your Martin supplier for assistance if you have any questions about how to install this product safely.

## Fixture location

Exterior Linear Series fixtures are intended for outdoor use. With an IP rating of 66, they are dust-resistant and able to withstand powerful water jets, but they are not submersible. Fixtures require free and unobstructed airflow around them to ensure adequate cooling.

Observe the following limitations in selecting a location:

- Respect the limitations listed under 'Safety information' on page 4.
- Do not allow water to collect on or near the pressure relief valve. Do not install the fixture in such a way that water can form a pool covering the valve membrane.
- Ensure sufficient drainage to cope with the heaviest rainfall. Make sure that water can drain away from the installation area at least as fast as it can enter it.
- Do not bury or locate the fixture in an unventilated space.
- If the fixture is operated at the maximum permitted ambient temperature, the housing can reach a temperature of up to 85° C (185° F). Restrict public access or locate the fixture so that it cannot accidentally be touched.

## Mounting the fixture



**Warning!** All fasteners used to mount Exterior Linear Series fixtures must be corrosion-resistant and strong enough to mount the fixture safely. Install a washer directly under the head of each fastener when anchoring the mounting bracket to the installation surface.

The fixture and mounting bracket are manufactured in corrosion-resistant anodized aluminum. Avoid direct contact with other types of metal, as this can cause galvanic corrosion. When fastening a mounting bracket or fixture to a metal surface that is not anodized aluminum:

- Use an electrically insulating material (such as rubber or plastic) or coating between the mounting bracket and the other metal.
- Use a non-conductive coating such as Delta Seal on fasteners (screws, bolts, washers, etc.) where they come into contact with the mounting bracket.

### Mounting brackets

The fixture's mounting brackets must be securely anchored to a suitable support. The mounting surface must be hard, fixed and flat. For bracket dimensions see illustration on right.

The fixture can be mounted at any angle. The mounting brackets allow the fixture to be manually tilted 105° for beam aiming adjustment.

Fasten the fixture securely with suitable mechanical fasteners. Do not stand it on a surface or leave it where it can be moved or fall over. Ensure that the surface and all fasteners used can support at least 10 times the weight of all fixtures and equipment they will support.

Anchor the mounting brackets to a flat surface. Fasten each bracket with two high-strength

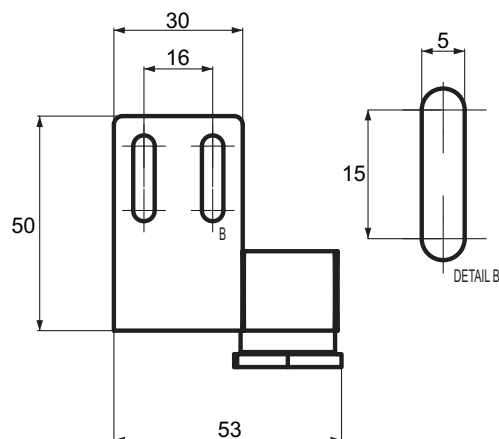



corrosion-resistant fasteners (recommended minimum properties: stainless steel A4-70 grade according to ISO 3506 or steel grade 8.8 according to ISO 898-1). All nuts used must be self-locking. Washers must be installed between the head of each fastener and the bracket.

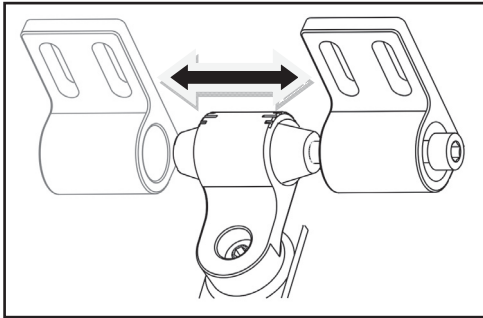

The mounting brackets can be installed with the mounting flanges to the inside (closer to the middle) or to the outside (closer to the ends). In most cases, installation with the flanges to the outside provides easier access to the hinge bolts for tilt adjustment.

To swap sides, remove the hinge bolt, place the mounting flange on the opposite cone, and refasten with the hinge bolt.

To install the mounting brackets on a fixture:

1. Prepare the mounting brackets as described above and loosen the hinge bolts.
2. See figure below-left. Align the long axis of each mounting bracket foot with the mounting bracket track. Insert two brackets in the track.
3. See figures below. Note which direction the mounting bracket hinges will have to pivot so that you can set the fixture to the desired angle. Turn each bracket a quarter turn in the direction that will let the hinge pivot correctly.

#### Fastening to the mounting surface

1. Fasten the flanges in the mounting brackets loosely to the mounting surface using two suitable fasteners in each flange.
2. Refer to 'Connecting power and data' on page 13 and connect the fixture power + data input to the output of the previous fixture.
3. Adjust the position of the mounting brackets as necessary. Tighten the fasteners in the flange and the lock screw on each mounting bracket.
4. Pivot the mounting brackets to the desired tilt angle and tighten the hinge bolts.

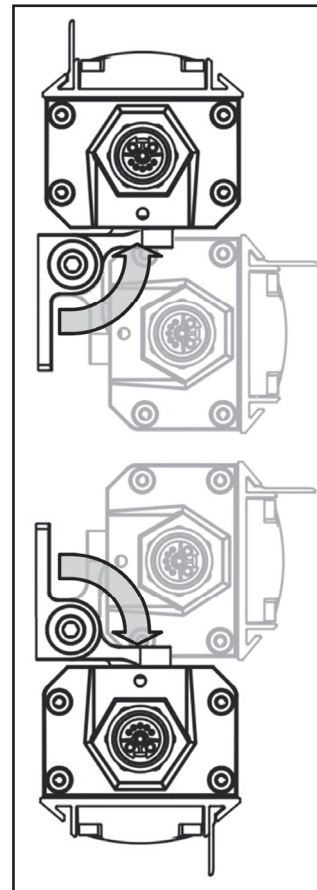
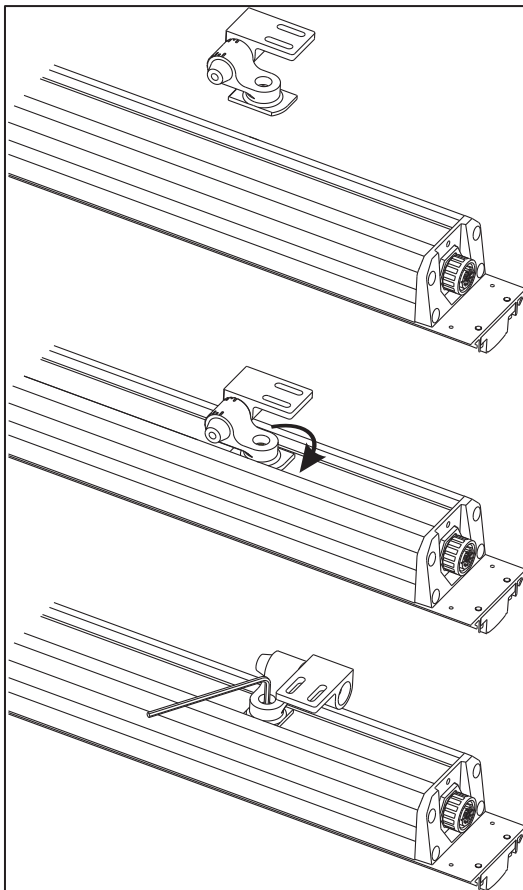

## Installing a Glare Shield

Accessory Glare Shields designed to limit light spill are available in 1 ft. (300 mm) and 4 ft. (1200 mm) lengths. See 'Accessories' on page 26. The Glare Shield is 25 mm (0.98 in.) high and slides into an accessory mounting channel in the fixture profile.

To install a Glare Shield:

1. See illustration on right. Align the Glare Shield with the mounting channel.
2. Slide the shield fully into the channel.
3. Secure the shield by fastening locking screws (arrowed) into the holes provided at both ends of the fixture. If you are installing a fixture at an angle that is not horizontal, apply a thread locking compound such as Loctite to the two screws before tightening them.

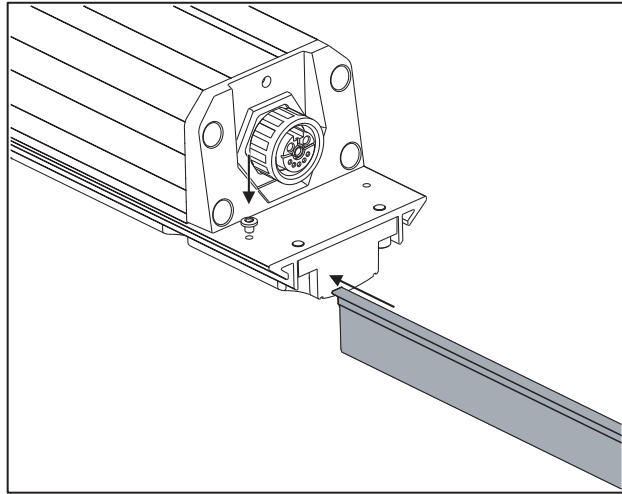

# AC power and data connection



**Warning!** Read 'Safety information' on page 4 before installing the fixture.

Electrical installation must be carried out by qualified professionals only. Lock out power to the entire installation before working on cables and connections.



For protection from dangerous electric shock, the fixture must be grounded (earthed). The AC power distribution system must be fitted with current overload and ground-fault (earth-fault) circuit breakers as well as a means to isolate fixtures from power and lock out power during service.

Never connect or disconnect a live power and data cable. Shut down power to the installation before connecting or disconnecting cables.

Make sure that cables from fixtures open into dry areas (e.g. junction boxes in dry locations). If there is a break or cut at any point in a cable (for example at a connection point), and if this is exposed to water, moisture can be drawn up the inside of the cable due to the vacuum effect of temperature fluctuations during operation. Ensure that the fixture is protected from the entry of water via the power cable by using IP66-rated connectors or junction boxes, or by protecting connectors with weatherproof housings.

Exterior Linear Series fixtures accept AC power at 100 - 277 V nominal, 50 or 60 Hz. Do not connect to power at any other voltage or frequency.

There is no power on/off switch. Power is applied to the fixtures as soon as they are connected to power. Provide a means to disconnect or shut down power to fixtures that is easily accessible and is located close to the fixtures.

Do not use an external dimming system to supply power to the fixture, as this may cause damage to the fixture that is not covered by the product warranty.

## Power requirements

Exterior Linear Series fixtures must be supplied with AC mains power at 100 - 277 V nominal, 50/60 Hz using either a grounded single-phase (live, neutral, ground/earth) distribution system or one phase of a grounded three-phase (3 live phases, neutral, ground/earth) distribution system.

The fixtures are designed to be connected directly to each other: power/data output to power/data input as shown below.

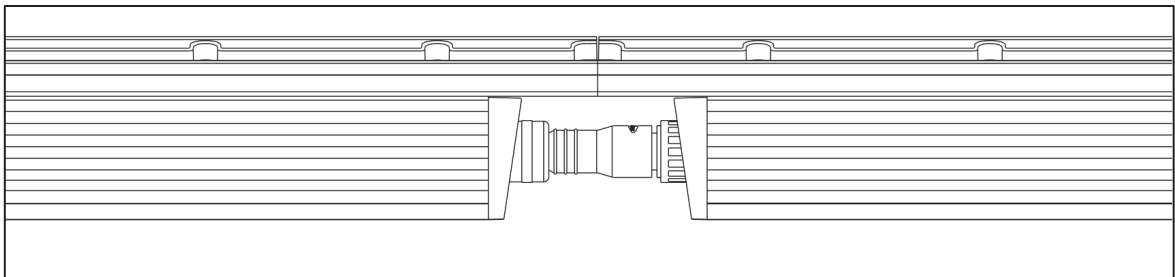

They can also be connected using the 0.2 m (7.8 inch), 1.5 m (4.9 ft.) or 10 m (32 ft.) extension cables listed under 'Accessories' on page 26.

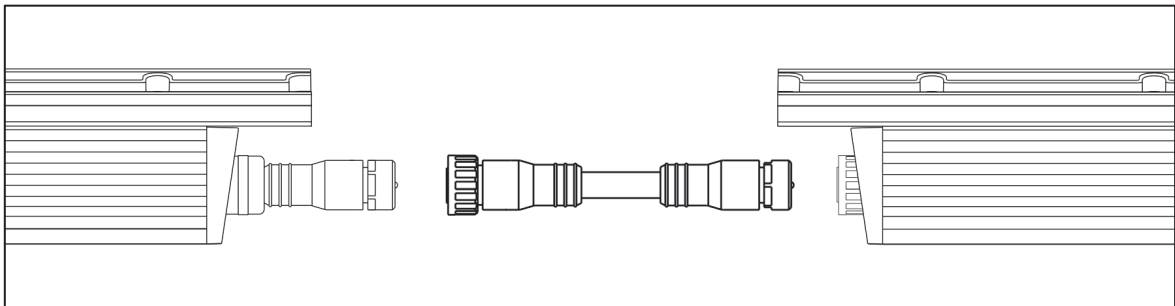

### Safety limits for chains of fixtures



**Warning!** Read this section carefully and respect the safety limits given, or you may create a risk of fire or electric shock. Consult your Martin™ supplier if you have any questions about installation safety.

#### Maximum total length of fixtures

The maximum permitted total length of fixtures, excluding cable, that you can connect in one chain is:

- 50 ft. (15.2 m) of fixtures at 120 V mains power
- 100 ft. (30.5 m) of fixtures at 240 V mains power
- 120 ft. (36.5 m) of fixtures at 277 V mains power

#### Maximum total length of cable

If a chain contains the permitted maximum total length of fixtures, the maximum total length of cable that you can add to the chain (as a lead-in before the first fixture and between fixtures) is:

- 230 ft. (70 m) of cable at 120 V mains power if the chain contains the permitted maximum of 50 ft. (15.2 m) of fixtures
- 328 ft. (100 m) of cable at 240 V mains power if the chain contains the permitted maximum of 100 ft. (30.5 m) of fixtures
- 328 ft. (100 m) of cable at 277 V mains power if the chain contains the permitted maximum of 120 ft. (36.5 m) of fixtures

#### Maximum total length of cable if total length of fixtures is less than the maximum

If the chain contains less than the permitted maximum length of fixtures, the maximum permitted length of cable that you can add to the chain increases. See the table below for details.

#### Maximum lengths of fixtures and cable in chains of Exterior Linear fixtures

Voltage	Maximum permitted total length of fixtures in chain	Maximum permitted total length of cable in chain	Increase in maximum permitted total length of cable if total length of fixtures is reduced
110 – 120 V	50 ft. (15.2 m)	230 ft. (70 m)	For every 5 ft. (1.5 m) of fixtures that you remove from the 50 ft. (15.2 m) maximum total length of fixtures in the chain, you can add 32 ft. (10 m) of cable to the 230 ft. (70 m) maximum permitted total length of cable in the chain.
220 – 240 V	100 ft. (30.5 m)	328 ft. (100 m)	For every 10 ft. (3 m) of fixtures that you remove from the 100 ft. (30.5 m) maximum total length of fixtures in the chain, you can add 32 ft. (10 m) of cable to the 328 ft. (100 m) maximum permitted total length of cable in the chain.
277 V	120 ft. (36.5 m)	328 ft. (100 m)	For every 10 ft. (3 m) of fixtures that you remove from the 120 ft. (36.5 m) maximum total length of fixtures in the chain, you can add 32 ft. (10 m) of cable to the 328 ft. (100 m) maximum permitted total length of cable in the chain.

In configurations where additional cable is mainly inserted *towards the end* of the chain, it may be possible to exceed slightly the maximum permitted total cable lengths given above. However, you may only exceed these maximum lengths in consultation with authorized Martin™ personnel or agents. Exceeding the

maximum permitted total number of fixtures or maximum permitted total length of cable in a chain may create a risk of fire or electric shock if the total current draw in the chain is not carefully calculated.

### Cable types

The first fixture in the chain is intended to be wired directly to a building's AC mains power supply and to the control data link inside a suitable weatherproof junction box. Cables for this purpose are available for compliance with US and EU electrical codes.

- In North America, use PVC cable, either:  
Power + Data Input Cable with 8-pin custom connector, 2 m (6.6 ft.), US, P/N 91611755, or  
Power + Data Input Cable with 8-pin custom connector, 10 m (32.8 ft.), US, P/N 91611157.
- In the EU, use rubber cable, either:  
Power + Data Input Cable with 8-pin custom connector, 2 m (6.6 ft.), EU, P/N 91611754, or  
Power + Data Input Cable with 8-pin custom connector, 10 m (32.8 ft.), EU, P/N 91611156.
- In other locations, consult with your Martin distributor to determine the appropriate cable type.

### Data network requirements

The lighting controller connects to Exterior Linear Series fixtures through the combined power and data cables. As with power, the first fixture in the chain is intended to be wired directly to the DMX data network inside a suitable weatherproof junction box. The output of the last fixture in the chain must be sealed and terminated with P/N 91611766, 'End Termination Cap for power + data link'.

Though other configurations are possible, the recommended configuration for the data network is to use one DMX universe for each chain of Exterior Linear Series fixtures. The following considerations must be taken into account when laying out the data network:

- 512 DMX channels are available in a single DMX universe. Each time the combined channel requirements of a group of connected fixtures exceeds 512, an additional DMX universe will be required.
- You can reliably connect up to 32 fixtures in a single daisy chain.
- Use RS-485 data cable designed for exterior use. RS-485 cable has low capacitance and a characteristic impedance of 85 to 150 Ohms. It is electrically shielded and has at least 1 twisted pair of conductors. The minimum recommended wire size is 0.25 mm<sup>2</sup> (24 AWG) for runs up to 200 meters (1000 ft.) and 0.32 mm<sup>2</sup> (22 AWG) for runs up 500 meters (1640 ft.).
- Branches may be added to the link using an opto-isolated splitter. Be sure to use an RDM compatible amplifier-splitter such as the Martin™ 5.5 Splitter. Each branch may itself connect up to 32 fixtures.
- An RDM amplifier may also be used to extend a network beyond 500 meters (1640 ft.) or to connect up to 32 additional fixtures to the daisy chain.
- The data link and each connected branch must be terminated at the end by installing an End Termination Cap for power + data link, P/N 91611766, on the output of the last fixture on the chain.
- Long parallel runs of AC power and control data cables may cause interference on the data link and must be avoided. Even if not required by law, use separate conduits for power and data cables.
- Make sure that data connections are totally protected from water, or the suction created by normal heating and cooling may suck moisture up the inside of the cable and into fixtures.
- Exterior Linear Series fixtures and cables support but do not use the second DMX data pair. The data network therefore can, but need not include the second data pair.

### Connecting power and data

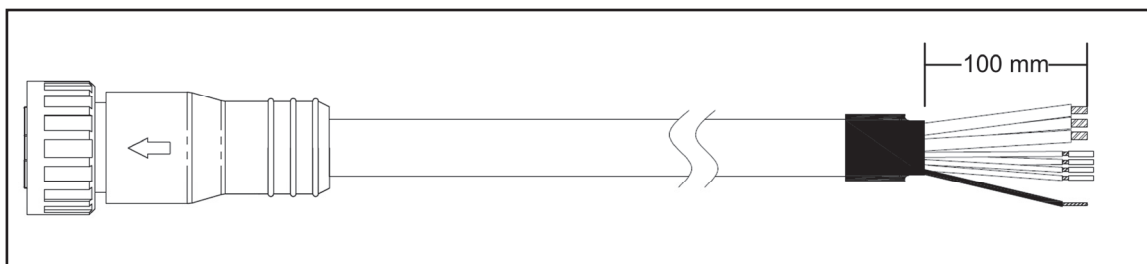

*Power + Data Input Cable*

To connect a single fixture or the first fixture in a fixture chain to power and data:

1. Lock out power to the installation.
2. Connect the Power + Data Input Cable power conductors to the distribution circuit as follows:
  - a) Connect the yellow/green wire to ground (earth).
  - b) Connect the black wire (US cable) or blue wire (EU cable) to neutral.
  - c) Connect the brown wire to live.
- d) Connect the Power + Data Input Cable data conductors to the data network as follows:
  - e) Connect the copper braid (pin 1) to Signal Common.
  - f) Connect the red wire (pin 2) to Data 1 cold (-ve).
  - g) Connect the gray wire (pin 3) to Data 1 hot (+ve).
  - h) (Optional) Connect the green wire (pin 4) to Data 2 cold (-ve), and the white wire (pin 5) to Data 2 hot (+ve).
3. Plug the Power + Data Input Cable into the input connector and screw tight by hand.
4. Check that all installation work is completed and carry out appropriate tests and safety checks before applying power.

To connect power and data to additional fixtures:

1. Lock out power to the installation. Never connect or disconnect a live Power + Data Cable!
2. Connect fixtures power/data thruput to power/data input, either directly or with extension cables.
3. Install a termination cap in the output of the last fixture in the chain as shown below.

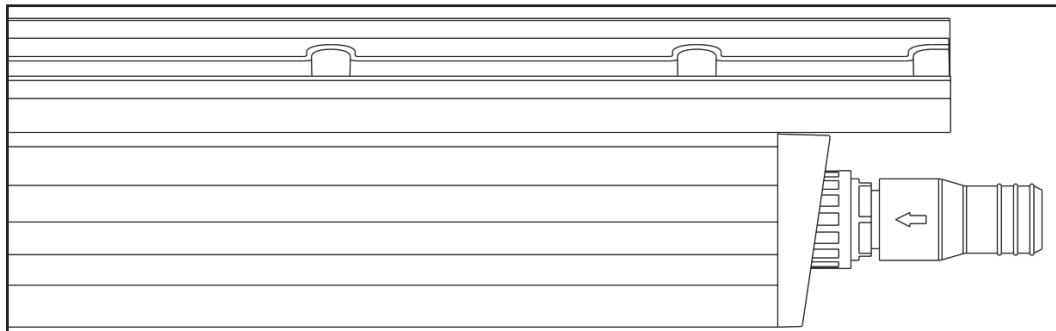

*Exterior Linear Termination Cap*

4. Ensure that all connections are tight and secure.
5. Check that all installation work is completed and carry out appropriate tests and safety checks before applying power.

# Setup



**Warning!** Read 'Safety information' on page 4 before operating the fixture.

This section explains the fixture settings and utilities that the user has access to via RDM (Remote Device Management according to ANSI/ESTA E1.20).

## RDM and Martin™ M-PC

Exterior Linear Series fixtures require an RDM-compatible controller to check and alter fixture settings, send control commands and retrieve fixture data. Martin™ offers a range of suitable controllers.

Martin™ M-PC is a Windows-based application available from Martin™ that lets you set up, manage and control a lighting installation from a PC that is connected to the installation via a DMX data link. To use Martin™ M-PC, connect a PC running the application to the data link via a USB-to-DMX interface box such as the Martin™ M-DMX (see 'Related Items' on page 26).

A full list of the RDM functions that Exterior Linear fixtures support is given at the end of this chapter. These functions are generally referred to using the more specific term 'PIDs' or 'Parameter IDs'.

### Step one: scanning for devices on the data link

Before you can communicate with fixtures using RDM, you must send a scan command (also called a device discovery command) to all the devices on the data link so that the RDM controller can identify them. It does this by retrieving each device's factory-set unique identifier (UID). This process can take some time depending on the number of devices on the link.

To identify the fixtures on the link:

1. Check that the fixtures are correctly connected to the RDM controller on the data link and that power is applied to all fixtures.
2. In Martin™ M-PC, go to RDM CONTROLLER → DISCOVER DEVICES.
3. Give the controller time to identify the devices on the link and prepare for communication with the devices.

## Setting up DMX behavior

### Setting DMX mode

This command lets you set the DMX mode of fixtures on the data link. Because DMX mode affects the number of DMX channels a fixture uses, it will affect the assignment of DMX addresses to fixtures. You should therefore set fixtures' DMX mode before you set their DMX addresses.

Exterior Linear fixtures can be set to either Standard DMX mode – **STD MODE** or Extended DMX mode – **EXD MODE**. Extended mode offers additional control functions but uses more DMX channels. See the 'DMX protocol' section at the end of this manual for an overview of the functions available and number of DMX channels used.

You can set the DMX mode of one fixture by sending a unicast RDM command to that one fixture only, or you can set the DMX mode of all the fixtures on the data link by sending a broadcast RDM command to all the devices on the link.

Procedures vary in different controllers, but to set the DMX mode in Martin™ M-PC:

1. Go to RDM CONTROLLER → Scan → Properties → Device Info → Change personality.
2. Select EXD MODE or STD MODE.
3. Press ENTER to confirm your selection.

### Setting DMX addresses

This command lets you set the DMX addresses of fixtures on the data link.

A fixture's DMX address is the first DMX channel it uses to receive data communication. It uses this channel and the channels immediately above it. If a fixture has DMX address 001 and the fixture uses four DMX channels, it will use channels 001, 002, 003 and 004. DMX address 005 will be available as a DMX address for the next fixture on the data link. If this fixture also uses four DMX channels, the next available DMX address will be 009, and so on.

You can set the DMX address of one fixture by sending a unicast RDM command to that one fixture only, or you can set all the fixtures on the data link to the same DMX address by sending a broadcast RDM

command to all the devices on the link. If all the fixtures have the same DMX address, they will behave identically and you will not be able to control any single fixture independently.

To set a DMX address:

1. In Martin™ M-PC, go to RDM CONTROLLER → Scan → Properties → Advanced → Choose PID → Set DMX START ADDRESS.
2. In the Message column, enter the DMX address that you want to give to the fixture (or give to all the fixtures if you are sending a broadcast command).
3. Press RDM SET to confirm your selection.
4. The Response column will show the setting result as either Success or Failed.

### Setting behavior when no DMX signal is present

This command lets you set the behavior of fixtures on the data link when the fixtures are not receiving DMX.

You can set behavior in one fixture by sending a unicast RDM command to that one fixture only, or you can set behavior in all the fixtures on the data link by sending a broadcast RDM command to all the devices.

Three options are available:

- Blackout – Fixture intensity set to zero light output when no DMX signal is received. You can consider this option if you intend to control the installation by DMX only.
- Dft slted val. (Default selected DMX value) – All LEDs go to 100% intensity when no DMX signal is received.
- Last rcved val (Last received DMX value) – Fixtures store the last DMX values they received in memory and use those values when no DMX signal is being received. This lets you set up how fixtures will appear each time they are powered on. If you create a scene by sending DMX values to the fixtures and then power the fixtures off, the fixtures will display that scene again each time you power them on, even if no DMX signal is present.

To set behavior when no DMX is present:

1. In Martin™ M-PC, go to RDM CONTROLLER → Scan → Properties → Device Info → Change personality.
2. The currently selected behavior is displayed.
3. Select Blackout, Dft slted val. or Last rcved val.
4. Press ENTER to confirm your selection.

## Dimming control

You can control the output intensity of the fixtures on the link via RDM.

You can control the intensity of one fixture by sending a unicast RDM command to that one fixture only, or you can control all the fixtures on the data link by sending a broadcast RDM command to all the devices on the link.

To control intensity:

1. In Martin™ M-PC, go to FUNCTION → MANUAL CONTROL → DMX TRANSMITTER
2. Scroll to an intensity level from 0 to 255.
3. Press ENTER to confirm your selection.

Exterior Linear fixtures have a dimming curve that corresponds to  $\Gamma = 2.0$

## Refresh rate control

It is possible to adjust the LED refresh rate of all the fixtures on the link to match the frame rate of video cameras. Setting a refresh rate that is a multiple of the video camera frame rate can eliminate flicker and stripes in video images, for example.

Refresh rates are displayed at the RDM controller as percentages. From 900 Hz to 1830 Hz, increasing by one percent increases the refresh rate by 10 Hz. From 1830 Hz to 25 000 Hz, increasing by one percent sets a larger increase in the refresh rate. See the list of percentages and frame rates shown below.

You can set the refresh rate of one fixture by sending a unicast RDM command to that one fixture only, or you can set the refresh rate of all the fixtures on the data link by sending a broadcast RDM command to all the devices on the link.



To set the LED refresh rate:

1. In Martin™ M-PC, go to RDM CONTROLLER → Scan → Properties → Advanced → Choose PID → Display level
2. Insert the percentage in Message column
3. Press RDM SET to confirm your selection.
4. The Response column will show the setting result as either Success or Failed.

### Refresh rates / percentages

*NB: These are preliminary figures – please expect minor changes to be announced April 2016.*

Percentage	Refresh rate
0% .....	900 Hz
1% .....	910 Hz
2% .....	920 Hz
3% .....	930 Hz
... ..	...
30% .....	1200Hz
... ..	...
93% .....	1830 Hz
94% .....	2500 Hz
95% .....	4000 Hz
96% .....	5000 Hz,
97% .....	10 000 Hz
98% .....	15 000 Hz
99% .....	20 000 Hz
100% .....	25 000 Hz

## Temperature, current draw and refresh rate status

You can display the following status information from the fixture:

- Temp – Fixture temperature.
- Amp – Fixture’s current draw in amps
- Refresh rate – Fixture’s LED refresh rate

To retrieve this information:

1. In Martin™ M-PC, go to RDM CONTROLLER → DISCOVER DEVICES → Get Sensor value.
2. Use the arrow keys on the keyboard to scroll and display temperature, current draw in amps and LED refresh rate for all fixtures.

## Overall fixture status

You can display general status information for a fixture.

To retrieve this status data:

1. In Martin™ M-PC, go to RDM CONTROLLER → DISCOVER DEVICES → Status check.
2. Overall fixture status is displayed.

## RDM

As a minimum, Exterior Linear fixtures support the following RDM functions:

### Device discovery

DISC_UNIQUE_BRANCH
DISC_MUTE
DISC_UN_MUTE

### Device management

	GET	SET
SUPPORTED_PARAMETERS	✓	
DEVICE_INFO	✓	
DEVICE_MODEL_DESCRIPTION	✓	
MANUFACTURER_LABEL	✓	
DEVICE_LABEL	✓	✓
FACTORY_DEFAULTS		✓
SOFTWARE_VERSION_LABEL	✓	
DMX_PERSONALITY	✓	✓
DMX_PERSONALITY_DESCRIPTION	✓	
DMX_START_ADDRESS	✓	✓
SLOT_DESCRIPTION	✓	
SENSOR_DEFINITION	✓	
SENSOR_VALUE	✓	
DEVICE_HOURS	✓	
LAMP_HOURS	✓	
LAMP_STATE (ON/OFF)	✓	
DEVICE_POWER_CYCLES	✓	
DISPLAY_LEVEL	✓	✓
IDENTIFY_DEVICE	✓	✓
RESET_DEVICE		✓

# Maintenance



**Warning!** There are no user-serviceable parts inside. Do not open the housing. Refer any service operation not described in this manual to Martin Professional™ or its authorized service agents.

Installation, on-site service and maintenance can be provided worldwide by the Martin Professional™ Global Service organization and its approved agents, giving owners access to Martin's expertise and product knowledge in a partnership that will ensure the highest level of performance throughout the product's lifetime. Please contact your Martin™ supplier for details.

Never try to repair the fixture by yourself as this may result in damage or malfunction and it may potentially void your product warranty. The only service operation the user can carry out on Exterior Linear Series fixtures is occasional cleaning.

Be aware that the output of LEDs, like all light sources, changes gradually over many thousands of hours of use. If you require products to perform to very precise color specifications, you may eventually need to make small readjustments at the lighting controller.

The light source in this product is not user-replaceable. When the light source LEDs reach the end of their service life, they may be replaced only by Martin™ Service, an authorized Martin™ Service agent or a similarly qualified person.

## Running test sequences

Exterior Linear Series fixtures are programmed with a test sequence that is activated by 'swiping' (moving) a magnet past a magnetic switch inside the fixture. The magnetic switch is located between the last two LEDs at the end of the fixture with the power + data input connection as shown below.

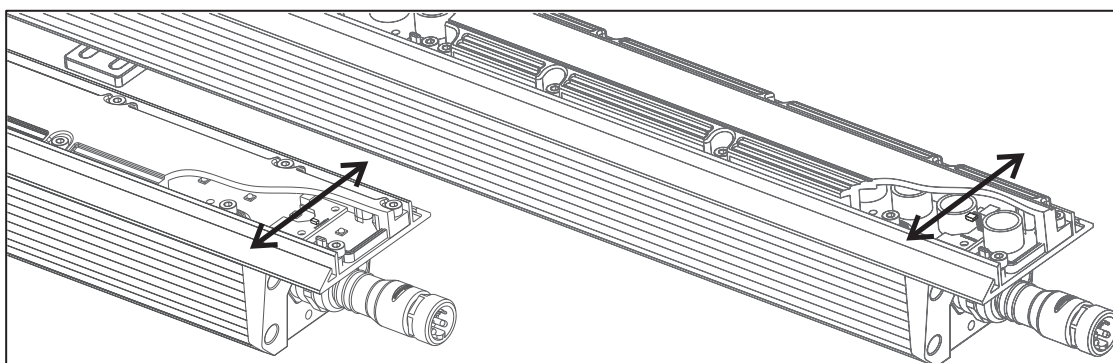

*Swipe magnet across Exterior Linear Cove (left) or Graze (right)*

We recommend that you use the Martin™ Service Tool shown to right, which contains a suitable magnet. See 'Related Items' on page 26.

Activating the magnetic switch lets you display the product's status and test the LEDs.



### Exterior Linear RGBW models (300/1200 Cove, 300/1200 Graze)

Swiping a magnet past the magnetic switch causes the fixture to step through the following sequence:

1. Display status code (see table below for meaning).
2. All LEDs at full intensity.
3. All red LEDs at full intensity.
4. All green LEDs at full intensity.
5. All blue LEDs at full intensity.
6. All white LEDs at full intensity.

7. All LEDs at 20% intensity.
8. Exit sequence and resume normal operation.

You can also resume normal operation by cycling power off and on. If you are sending a DMX signal to the fixture, it will exit the sequence and enter normal DMX operation again after a short period.

Fixture status is indicated as follows:

LED color	Signal	Status
Blue	Fast flash	Busy (booting or uploading SW)
Blue	Slow flash	No DMX detected
Green/blue	Alternating	Running normally in DMX mode

### Exterior Linear variable white models (320/1220 Cove, 320/1220 Graze)

Swiping a magnet past the magnetic switch causes the fixture to step through the following sequence:

1. Display status code (see table below for meaning).
2. All LEDs at full intensity.
3. All cold white LEDs at full intensity.
4. All neutral white LEDs at full intensity.
5. All warm white LEDs at full intensity.
6. All LEDs at 20% intensity.
7. Exit sequence and resume normal operation.

You can also resume normal operation by cycling power off and on. If you are sending a DMX signal to the fixture, it will exit the sequence and enter normal DMX operation again after a short period.

Fixture status is indicated as follows.

LED color	Signal	Status
Cold	Fast flash	Busy (booting or uploading SW)
Cold	Slow flash	No DMX detected
Cold/warm	Alternating	Running normally in DMX mode

## Managing humidity

Exterior Linear Series fixtures are IP66-rated and are designed to resist water and moisture in environments with widely varying climate, temperature and humidity conditions. But if fixtures are not managed correctly during installation and service, water and moisture can enter, leading to humidity and condensation inside the fixtures. Follow the precautions in this chapter to avoid this problem.

### General

- Air, and even water, can be sucked along cables and into fixtures. A cracked or porous cable jacket can allow water into the cable. Replace any cable that is not in perfect condition. Make sure that cables from fixtures open into dry areas (e.g. junction boxes in dry locations).
- Do not clean fixtures with high-pressure water jets or immerse them.

### Pressure relief valve

A valve with a Gore-Tex membrane on the back of the fixture equalizes pressure by allowing air to pass through it when the fixture heats up and cools down, but at the same time it acts as a barrier to water in liquid form. The expulsion of warm air (with a slightly higher water vapor content) and intake of cool air (with a slightly lower water vapor content) prevents humidity buildup over time, provided that the valve works correctly and the fixture is correctly sealed.

Pressure relief valves have a limited service life. They become blocked over time as the micropores in the membrane fill with particles. When a valve becomes blocked, excess pressure can damage seals or cause air and even water to be sucked into the fixture along cables. A blocked valve cannot be cleaned and must be replaced if it shows any signs of contamination or is not in perfect condition.

For maximum fixture service life, have the pressure relief valve replaced after an extended period of use. Intervals for valve replacement depend on the installation environment. Please consult your Martin dealer about a suitable replacement schedule. To ensure optimum humidity control, valve replacement must be carried out by Martin™ Service.

## Cleaning

Regular cleaning is essential for fixture life and performance. Buildup of dust and dirt degrades the fixture's light output and cooling ability.

Cleaning schedules will vary greatly depending on the operating environment. It is therefore impossible to specify precise cleaning intervals for the Exterior Linear Series. Inspect fixtures within their first few weeks of operation to see whether cleaning is necessary. Check again at frequent intervals. This procedure will allow you to assess cleaning requirements in your particular situation. If in doubt, consult your Martin™ dealer about a suitable maintenance schedule.

Do not use products that contain solvents, abrasives or caustic agents for cleaning, as they can cause surface damage to the fixture. The aluminum housing and front glass can be cleaned with mild detergents such as those for washing cars.

To clean the housing and front glass:

1. Isolate the fixture from AC power and allow the fixture to cool for 20 minutes.
2. Visually check that the silicone seals and the power and data cables are in good condition. If any seal or cable shows signs of damage, cracking or loss of water resistance, stop cleaning the fixture and contact a Martin™ authorized service technician for replacement.
3. If seals are in good condition, rinse off loose dirt with a hose or low-pressure water spray.
4. Wash the aluminum housing and front glass using warm water with a little mild detergent and a soft brush or sponge. Do not use abrasive cleaners.
5. Rinse with clean water and wipe dry.

# DMX protocol

## Exterior Linear Series 300 & 1200 RGBW models

RGBW color mixing models offer 0 to 100% intensity control of red, green, blue and white:

- **Standard DMX mode** gives RGBW control of the fixture using one channel per color. Fixtures in standard mode therefore use four DMX channels.
- **Extended DMX mode** is available on 1200 models. Extended mode gives independent RGBW control of four 300 mm segments. 1200 models in extended mode therefore use sixteen DMX channels.

Channel, Standard Mode	Channels, Extended Mode	Value	Function
1	1, 5, 9, 13	0-255	Red: 0-100%
2	2, 6, 10, 14	0-255	Green: 0-100%
3	3, 7, 11, 15	0-255	Blue: 0-100%
4	4, 8, 12, 16	0-255	White: 0-100%

## Exterior Linear Series 320 & 1220 variable white models

Variable white models offer 0 to 100% dimming control and color temperature control from 2700 K to 6500 K:

- **Standard DMX mode** uses one channel to control intensity and one channel to control color temperature. Fixtures in standard mode therefore use two DMX channels.
- **Extended DMX mode** is available on 1220 models. Extended mode gives independent color temperature control of four 300 mm segments. 1220 models in extended mode therefore use eight DMX channels.
- **Standard three-channel DMX mode** uses one channel to control 2700 K intensity, one to control 4000 K intensity and one to control 6500 K intensity.
- **Extended three-channel DMX mode** is also available on 1220 models. Extended three-channel mode uses one channel to control 2700 K intensity, one to control 4000 K intensity and one to control 6500 K intensity independently on four 300 mm segments. 1220 models in extended mode therefore use twelve DMX channels.

### Standard and Extended modes

Channel, Standard Mode	Channels, Extended Mode	Value	Function
1	1, 3, 5, 7	0-255	Intensity 0-100%
2	2, 4, 6, 8	0 1-255	<i>No function</i> Color temperature 2700-6500 K

### Standard 3-channel and Extended 3-channel modes

Channel, Standard 3-Channel Mode	Channels, Extended 3-Channel Mode	Value	Function
1	1, 4, 7, 10	0-255	2700 K intensity 0-100%
2	2, 5, 8, 11	0-255	4000 K intensity 0-100%
3	3, 6, 9, 12	0-255	6500 K intensity 0-100%

# Specifications

## Physical

### **300/320 Cove**

Length .....	305 mm (12.0 in.)
Width .....	72 mm (2.8 in.)
Height .....	95 mm (3.8 in.) including bracket
Weight .....	1.6 kg (3.6 lbs.)

### **300/320 Graze**

Length .....	305 mm (12.0 in.)
Width .....	72 mm (2.8 in.)
Height .....	99 mm (3.9 in.) including bracket
Weight .....	1.5 kg (3.4 lbs.)

### **1200/1220 Cove**

Length .....	1219 mm (48.0 in.)
Width .....	72 mm (2.8 in.)
Height .....	95 mm (3.8 in.) including bracket
Weight .....	6.4 kg (14.2 lbs.)

### **1200/1220 Graze**

Length .....	1219 mm (48.0 in.)
Width .....	72 mm (2.8 in.)
Height .....	99 mm (3.9 in.) including bracket
Weight .....	6.0 kg (13.3 lbs.)

## Dynamic Effects

### **300/1200 Cove, 300/1200 Graze**

Intensity .....	0 - 100%
Color mixing .....	RGBW

### **320/1220 Cove, 320/1220 Graze**

Intensity .....	0 - 100%
Color temperature control .....	2700 - 6500 K

## Control and Programming

Control systems .....	DMX, RDM
DMX compliance .....	USITT DMX512/1990
RDM compliance .....	ANSI/ESTA E1.20
User interface .....	Magnetic switch to call up fixture status and test fixture

### **300/1200 Cove, 300/1200 Graze**

DMX channels, standard / extended mode* .....	4/16
---	------

### **320/1220 Cove, 320/1220 Graze**

DMX channels, standard / extended / 3-channel standard / 3-channel extended mode* .....	2/8/3/12
---	----------

\*Extended modes are available on 1200 and 1220 models only

## Optics

### **300/320/1200/1220 Cove**

Light source .....	3 W CREE XP-E2 LEDs
Beam angle .....	120°
Minimum LED lifetime .....	50 000 hours (to >70% luminous output)*

### **300/320/1200/1220 Graze**

Light source .....	3 W CREE XP-E2 LEDs
Beam angle variants .....	10°, 15°, 60°, 10° x 60°
Minimum LED lifetime .....	50 000 hours (to >70% luminous output)*

\*Figure obtained under manufacturer's test conditions



## Photometric Data

### 300/320 Cove

Total luminous output ..... 700 lumens

### 1200/1220 Cove

Total luminous output ..... 2800 lumens

### 300/320 Graze

Total luminous output ..... 600 lumens

### 1200/1220 Graze

Total luminous output ..... 2800 lumens

*Please see [www.martin.com](http://www.martin.com) for full photometric specifications.*

## Construction



Housing ..... Aluminum  
Finish ..... Clear anodized (standard) or white (optional)  
Lens ..... Frosted polycarbonate  
Ingress protection rating ..... IP66  
Impact protection rating ..... IK08  
RoHS compliant

## Installation

Orientation ..... Any  
Mounting ..... Direct with included brackets and user-supplied fasteners  
Minimum distance to illuminated surfaces ..... 0.2 m (8 in.)

## Connections

Power and data in/thru ..... 8-pin custom connectors

## Electrical

AC power ..... 100 -277 V nominal, 50/60 Hz  
Power supply unit ..... Auto-ranging electronic switch-mode  
Maximum total length of fixtures in chain at 120 V ..... 15.24 m (50 ft.)  
Maximum total length of fixtures in chain at 240 V ..... 30.48 m (100 ft.)

## Typical power consumption

100-240 V, 50/60 Hz ..... 20 W per foot +/- 1 W, PF 0.95 +/- 0.05  
277 V, 50/60 Hz ..... 20 W per foot +/- 1 W, PF 0.90 +/- 0.05

*Power figures are typical, not maximum. Measurements made at nominal voltage. Allow for +/- 10% deviation. PF = Power factor.*

## Thermal

Cooling ..... Convection  
Maximum surface temperature ..... 70° C (158° F)  
Maximum ambient temperature (Ta max.) ..... 45° C (113° F)  
Minimum ambient temperature (Ta min.) ..... -30° C (-22° F)

## Approvals



EU safety ..... EN 60598-2-1, (EN 60598-1), EN 60598-2-5, EN 62471, EN 62493  
EU EMC ..... EN 55015, EN 55032 (EN 55103-1), EN 55103-2, EN 61547, EN 61000-3-2, EN 61000-3-3  
US safety ..... ANSI/UL 1598  
US EMC ..... 47 CFR Part 15 Class B  
Canadian safety ..... CSA C22.2 No. 250.0  
Australia/NZ (pending) ..... RCM

## Included Items

- User manual
- Two adjustable mounting brackets

## Accessories

### Optical

- Exterior Linear 300 glare shield, set of 4.....P/N 91611752
- Exterior Linear 1200 glare shield, set of 4.....P/N 91611753

### Cables

- Power + Data Input Cable with 8-pin custom connector, 2 m (6.6 ft.), EU .....P/N 91611754
- Power + Data Input Cable with 8-pin custom connector, 2 m (6.6 ft.), US .....P/N 91611755
- Power + Data Input Cable with 8-pin custom connector, 10 m (32.8 ft.), EU .....P/N 91611156
- Power + Data Input Cable with 8-pin custom connector, 10 m (32.8 ft.), US .....P/N 91611157
- Power + Data Extension Cable with 8-pin custom connectors, 0.2 m (0.7 ft.), EU.....P/N 91611758
- Power + Data Extension Cable with 8-pin custom connectors, 0.2 m (0.7 ft.), US.....P/N 91611759
- Power + Data Extension Cable with 8-pin custom connectors, 1 m (3.3 ft.), EU.....P/N 91611760
- Power + Data Extension Cable with 8-pin custom connectors, 1 m (3.3 ft.), US.....P/N 91611761
- Power + Data Extension Cable with 8-pin custom connectors, 5 m (16.4 ft.), EU.....P/N 91611762
- Power + Data Extension Cable with 8-pin custom connectors, 5 m (16.4 ft.), US.....P/N 91611763
- Power + Data Extension Cable with 8-pin custom connectors, 10 m (32.8 ft.), EU.....P/N 91611764
- Power + Data Extension Cable with 8-pin custom connectors, 10 m (32.8 ft.), US.....P/N 91611765
- End Termination Cap for power + data link .....P/N 91611766

## Related Items

- Martin™ Test Tool with magnetic swiper, set of 10.....P/N 91610139
- Martin™ Software Uploader 2.....P/N 91611770

## Ordering Information

### Cove Lighting Fixtures



- Exterior Linear 300 Cove, 120° (1 ft., RGBW).....P/N 90356976
- Exterior Linear 1200 Cove, 120° (4 ft., RGBW).....P/N 90356979
- Exterior Linear 320 Cove, 120° (1 ft., CTC) .....P/N 90356977
- Exterior Linear 1220 Cove, 120° (4 ft., CTC) .....P/N 90356978

### Graze Lighting Fixtures

- Exterior Linear 300 Graze, 10° (1 ft., RGBW) .....P/N 90356987
- Exterior Linear 300 Graze, 15° (1 ft., RGBW) .....P/N 90356970
- Exterior Linear 300 Graze, 60° (1 ft., RGBW) .....P/N 90356971
- Exterior Linear 300 Graze, 10°x60° (1 ft., RGBW) .....P/N 90356972
- Exterior Linear 320 Graze, 10° (1 ft., CTC) .....P/N 90356988
- Exterior Linear 320 Graze, 15° (1 ft., CTC) .....P/N 90356975
- Exterior Linear 320 Graze, 60° (1 ft., CTC) .....P/N 90356974
- Exterior Linear 320 Graze, 10°x60° (1 ft., CTC) .....P/N 90356973
- Exterior Linear 1200 Graze, 10° (4 ft., RGBW) .....P/N 90356986
- Exterior Linear 1200 Graze, 15° (4 ft., RGBW) .....P/N 90356980
- Exterior Linear 1200 Graze, 60° (4 ft., RGBW) .....P/N 90356981
- Exterior Linear 1200 Graze, 10°x60° (4 ft., RGBW) .....P/N 90356982
- Exterior Linear 1220 Graze, 10° (4 ft., CTC) .....P/N 90356989
- Exterior Linear 1220 Graze, 15° (4 ft., CTC) .....P/N 90356985
- Exterior Linear 1220 Graze, 60° (4 ft., CTC) .....P/N 90356984
- Exterior Linear 1220 Graze, 10°x60° (4 ft., CTC) .....P/N 90356983

*Specifications subject to change without notice. For latest product specifications, see [www.martin.com](http://www.martin.com)*

Exterior Linear Series from Martin™  
Designed in Denmark - assembled in China

 	<p><b>Disposing of this product</b></p> <p>Martin™ products are supplied in compliance with Directive 2012/19/EC of the European Parliament and of the Council of the European Union on WEEE (Waste Electrical and Electronic Equipment), where applicable. Help preserve the environment! Ensure that this product is recycled at the end of its life. Your supplier can give details of local arrangements for the disposal of Martin products</p>
--	--











---

[www.martin.com](http://www.martin.com) · Olof Palmes Allé 18 · 8200 Aarhus N · Denmark  
Tel. +45 8740 0000 · Fax +45 8740 0010