

READ AND SAVE THESE INSTRUCTIONS

P/N 35010041-A

RUSH CLUB SMOKE DUAL™

user manual



Dimensions

All dimensions are in millimeters

Haze Head

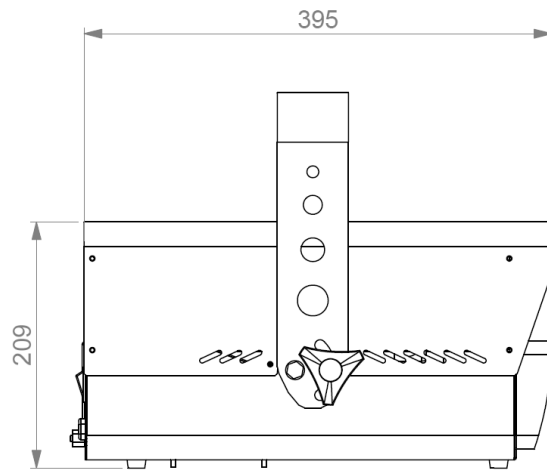
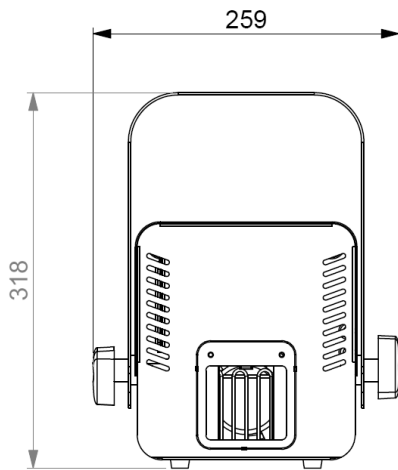

Fog Head

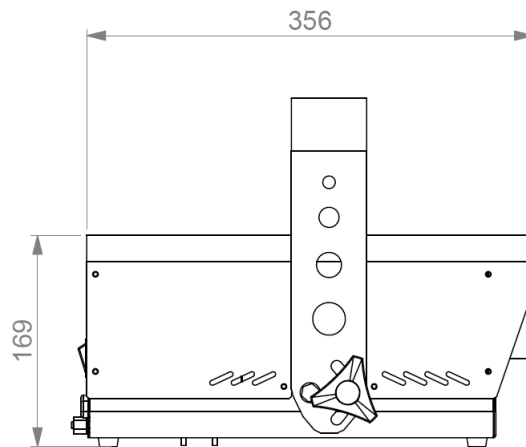
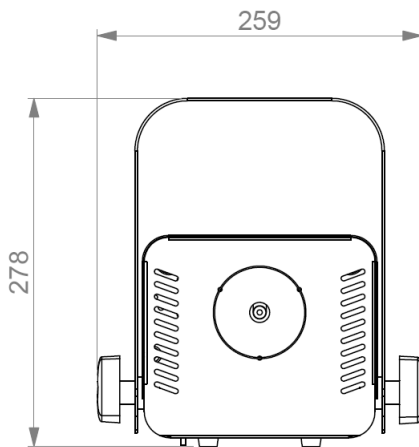

Pump Unit

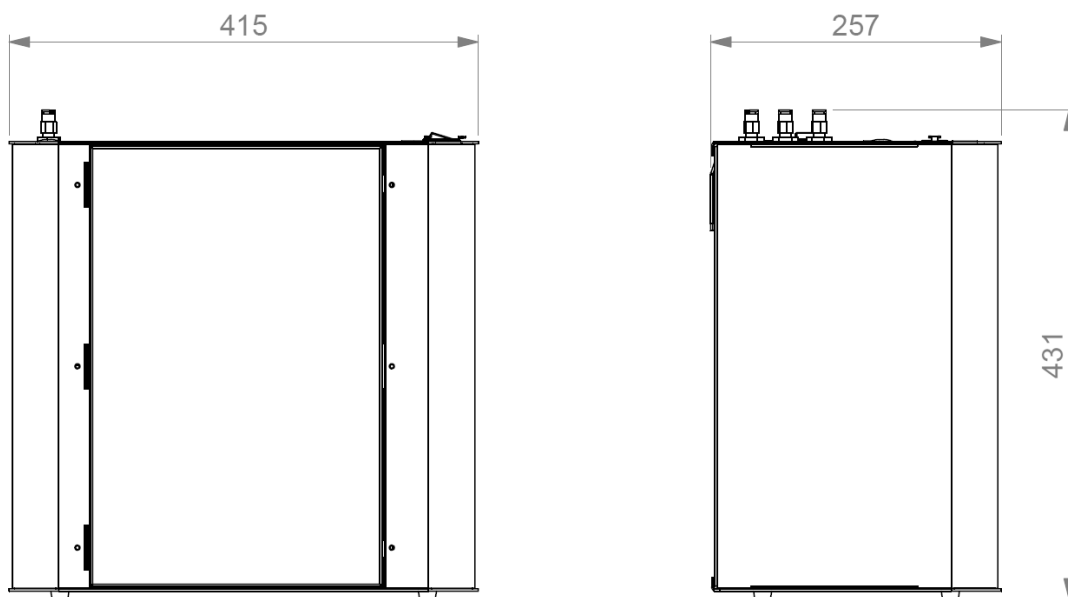

© 2013-2015 Martin Professional ApS. Information subject to change without notice. Martin Professional and all affiliated companies disclaim liability for any injury, damage, direct or indirect loss, consequential or economic loss or any other loss occasioned by the use of, inability to use or reliance on the information contained in this manual. The Martin logo, the RUSH by Martin logo, the RUSH by Martin name, the Martin name and all other trademarks in this document pertaining to services or products by Martin Professional or its affiliates and subsidiaries are trademarks owned or licensed by Martin Professional or its affiliates or subsidiaries.

Martin Professional • Olof Palmes Allé 18 • 8200 Aarhus N • Denmark • www.martin.com

Contents

<i>Dimensions</i>	2
<i>Contents</i>	4
<i>Safety information</i>	5
<i>Product overview</i>	8
<i>Product description</i>	8
<i>Features at a glance</i>	8
<i>Product details</i>	9
<i>Quick Start</i>	12
<i>Setting up</i>	12
<i>Making fog and haze</i>	12
<i>Installation and setting up</i>	13
<i>Location</i>	13
<i>AC power</i>	13
<i>Setting up</i>	14
<i>Final checks</i>	16
<i>Turning on the power</i>	16
<i>Control settings</i>	17
<i>Overview</i>	17
<i>Setting Fog Run modes</i>	17
<i>Setting output density for Fog heads</i>	17
<i>Setting Haze Run modes</i>	17
<i>Setting output density for Haze heads</i>	18
<i>Setting the Timer</i>	18
<i>Setting the DMX base address</i>	18
<i>Setting the master-slave link mode</i>	18
<i>Priming the system after fluid out</i>	18
<i>Priming system with Quick access buttons</i>	19
<i>Resetting options to factory settings</i>	19
<i>Remote control</i>	21
<i>Overview</i>	21
<i>Functions</i>	21
<i>Connection</i>	21
<i>DMX control</i>	23
<i>Overview</i>	23
<i>Connection</i>	23
<i>DMX functions</i>	23
<i>Fog fluid types</i>	25
<i>Basic service</i>	26
<i>Cleaning</i>	26
<i>Fuse replacement</i>	26
<i>Troubleshooting</i>	27
<i>Status messages</i>	28
<i>Resetting the system after fluid out</i>	28
<i>Specifications</i>	29

Safety information



Read the safety precautions in this manual before installing, operating or servicing this product.

The following symbols are used to identify important safety information:



Caution! Safety hazard. Risk of severe injury or death.



Caution! Burn hazard. Hot surface. Do not touch.



Danger! Hazardous voltage. Contact will cause electric shock.



Caution! Fire hazard.



Warning! This product is not for household use. It presents risks of injury due to electric shock, burns, falls and respiratory problems!

Read this manual before operating the system, follow the safety precautions listed below, and observe all warnings in this manual and printed on the system. Use the system only as described in this manual and in accordance with local laws and regulations.

If you have questions about how to operate the system safely, or if you have followed the instructions in this manual and the system is malfunctioning, please contact Martin Service.

Preventing electric shocks



- Always ground (earth) the system electrically.
- Use only a source of AC power that complies with local building and electrical codes, and that has both overload and ground-fault protection.
- Before connecting the system to power, check that the voltage indicated on the system's serial label matches your local AC power voltage. If your AC power voltage does not match, do not use the system. Contact Martin Service for assistance.
- Before using the system, check that all power distribution equipment and cables are in perfect condition and rated for the current requirements of all connected devices.
- If the system or any cables connected to it are in any way damaged, defective, wet, or show signs of overheating, stop using the system and contact Martin Service for assistance. If the supply cord is damaged, it must be replaced by a special cord or assembly available from the manufacturer or its service agent.
- Disconnect the system from AC power before servicing and when not in use.

- *This system is not waterproof and should not be exposed to wet outdoor conditions. Do not immerse in water or any other liquid. Do not expose to high-pressure water jets.*
- *Do not spill fluid over or inside the system. If fluid is spilled, disconnect AC power and clean with a damp cloth. If fluid is spilled onto electronic parts, take the system out of service and contact Martin for advice.*
- *Do not remove the covers or attempt to repair a faulty system. Refer any service not described in this manual to Martin.*
- *Do not operate the system if any parts are damaged, defective or missing.*
- *Moisture and electricity do not mix. Do not aim fog output at electrical connections or devices.*

Preventing burns and fire



- *The fog produced by the system is hot enough to cause burns when it leaves the nozzle, and very hot droplets of fluid escape occasionally. Keep people and objects at least 60cm (24 inches) away from the fog output nozzle.*
- *Do not touch the fog output nozzle during or after use – it becomes extremely hot and remains hot for several hours after the system has been shut down.*
- *Fog output contains glycol, a flammable alcohol that burns with an almost invisible blue flame. Do not point fog output at sources of ignition such as open flames or pyrotechnic effects.*
- *Do not attempt to bypass thermostatic switches, fluid sensors or fuses.*
- *Replace fuses only with ones of the type and rating specified in this manual for the system.*
- *Provide a minimum free space of 100mm (4 inches) around the system.*
- *Provide a minimum free space of 500mm (20 inches) around fans and air vents and ensure free and unobstructed air flow to and around the system.*
- *Keep the system at least 60cm (24 inches) away from combustible and heat-sensitive materials.*
- *Do not operate the system if the ambient temperature (T_a) is below 5° C (41° F) or above 40° C (104° F).*
- *Do not operate the system if the relative air humidity exceeds 80%.*

Preventing injuries

- *Fasten the system securely to a fixed surface or structure when in use. The system is not portable when installed.*
- *Ensure that any supporting structure and/or hardware used can hold at least 10 times the weight of all the devices they support.*
- *If suspending from a rigging structure, fasten the system to a rigging clamp. Do not use safety cables as the primary means of support.*
- *If the system is installed in a location where it may cause injury or damage if it falls, install as directed in this manual a secondary attachment such as a safety cable that will hold the system if a primary attachment fails. The secondary attachment must be approved by an official body such as TÜV as a safety attachment for the weight that it secures, must comply with EN 60598-2-17 Section 17.6.6 and must be capable of bearing a*

static suspended load that is ten times the weight of the system and all installed accessories.

- *Check that all external covers and rigging hardware are securely fastened.*
- *Block access below the work area and work from a stable platform whenever installing, servicing or moving the system.*
- *Do not operate the system with missing or damaged covers or shields.*
- *In the event of an operating problem, stop using the system immediately and disconnect it from power. Do not attempt to use a system that is obviously damaged.*
- *Do not modify the system in any way not described in this manual or install other than genuine RUSH by Martin™ parts.*
- *Refer any service operation not described in this manual to a qualified technician.*
- *Fog output can cause condensation. Do not point the output at smooth floors. Floors and surfaces may become slippery. Check these frequently and wipe dry as necessary to avoid any danger of slipping.*
- *Ensure at least 2 m visibility in areas where fog is being produced.*
- *Fog fluid contains food-grade glycols in solution but may present health risks if swallowed. Do not drink it. Store it securely. If eye contact occurs, rinse with water. If fluid is swallowed, give water and obtain medical advice.*
- *This appliance is not intended for use by persons (including children) with reduced physical sensory or mental capabilities, or lack of experience and knowledge, unless they have been given supervision or instruction concerning use of the appliance by a person responsible for their safety. Children should be supervised to ensure that they do not play with the appliance.*

Preventing breathing problems



- *A system can operate safely only with the fog fluid it is designed for. Use the system only with fluids specified under “Fog fluid options” on page 25 or you may cause the release of toxic gases, presenting a severe health hazard. You will also probably damage the system.*
- *Do not create dense fog in confined or poorly ventilated areas.*
- *Do not expose people with health problems (including allergic and/or respiratory conditions such as asthma) to fog output.*
- *Do not point fog output directly at a person’s face or at face height.*

*For the latest user documentation and other information for this and all Martin™ products, please visit the Martin website at <http://www.martin.com>
If you have any questions about how to install, operate or service the fixture safely, please contact your Martin™ distributor (see www.martin.com/distributors for details) or call the Martin™ 24-hour service hotline on +45 8740 0000, or in the USA on 1-888-tech-180.*

Product overview

Product description

The RUSH Club Smoke Dual™ is a top of the range atmosphere system from Martin Professional featuring multiple remote fog or haze heads with a base pump/fluid unit. Its remote heads allow the base unit to be conveniently located for fluid refill while the heads can be positioned in the ideal location for even fogging or hazing of the venue.

Designed using the latest fog system technology, the RUSH Club Smoke Dual™ is capable of generating a variable level of fog or haze from up to 6 heads controlled in pairs, which are connected using a simple push together fluid line and a single control cable.

Congratulations on your purchase of the RUSH Club Smoke Dual™ from Martin. Details of the full range of Martin products are available on our website at www.martin.com.

Features at a glance

- *1-6 Fog or Haze heads per system*
- *Flying/hanging brackets as standard*
- *Continuous output*
- *Water-based fluid with long hang time*
- *Low noise*
- *Lightweight*
- *Variable output control for each head pair using DMX*
- *10 liter (2.64 US gal.) fluid capacity*
- *“Out of Fluid” sensing using pressure sensor*
- *Valved output connectors on pump unit*
- *On-board DMX 3-pin and 5-pin*
- *User-friendly on-board control panel*
- *Optional external fluid connection and Digital Remote Control*



Use only Martin RUSH Club Smoke Dual Fluid™. Use of other fluid will void warranty.

Product details

Fog Head

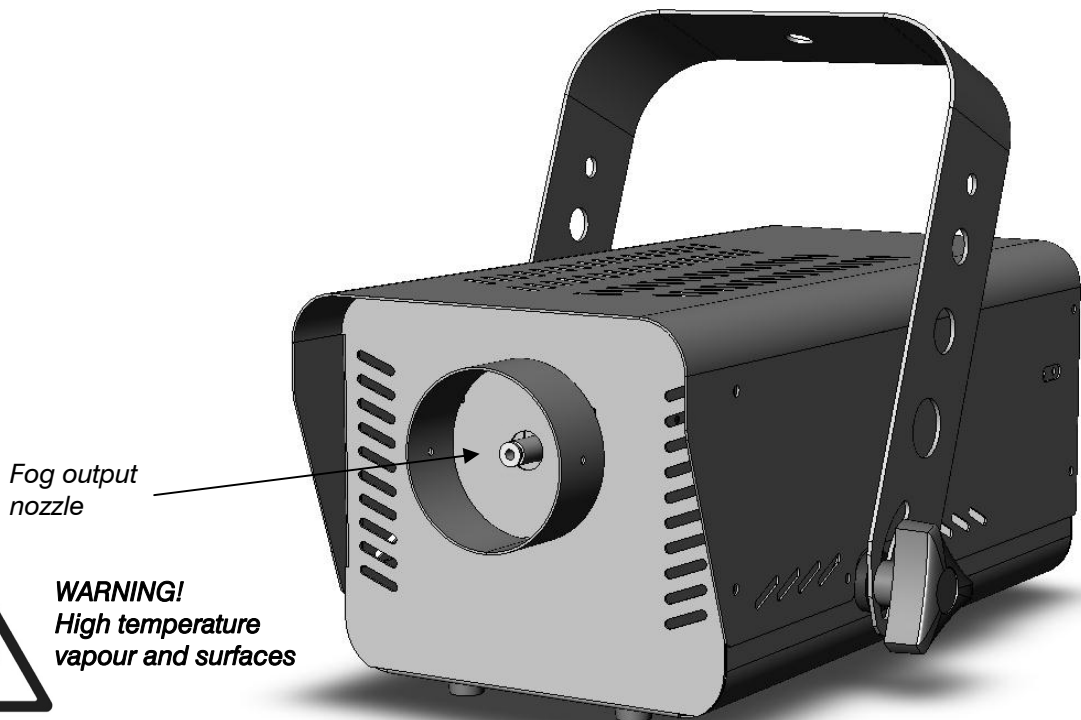
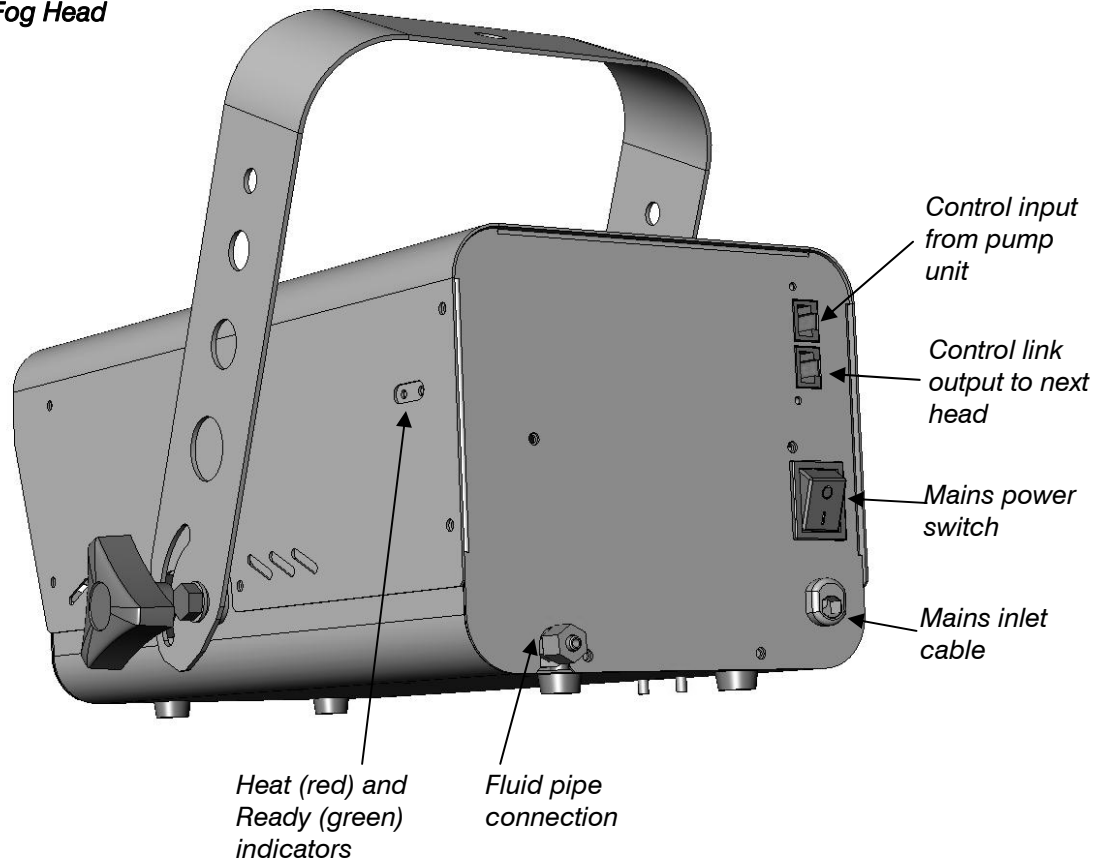

Haze Head

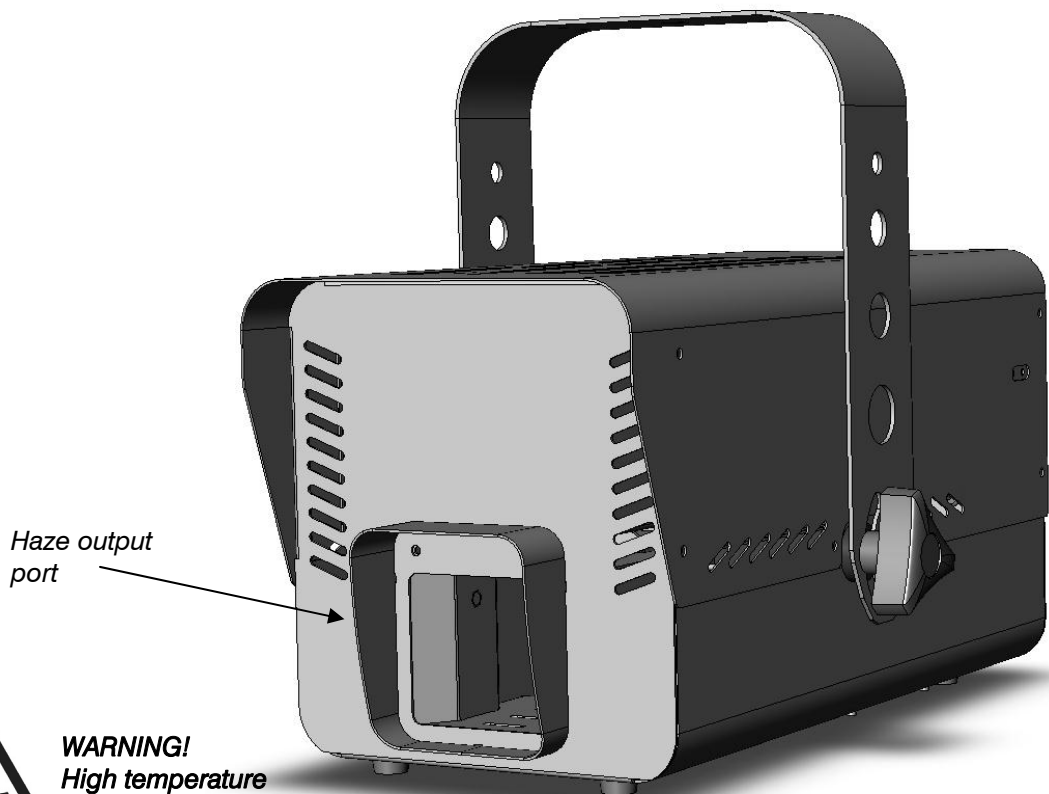
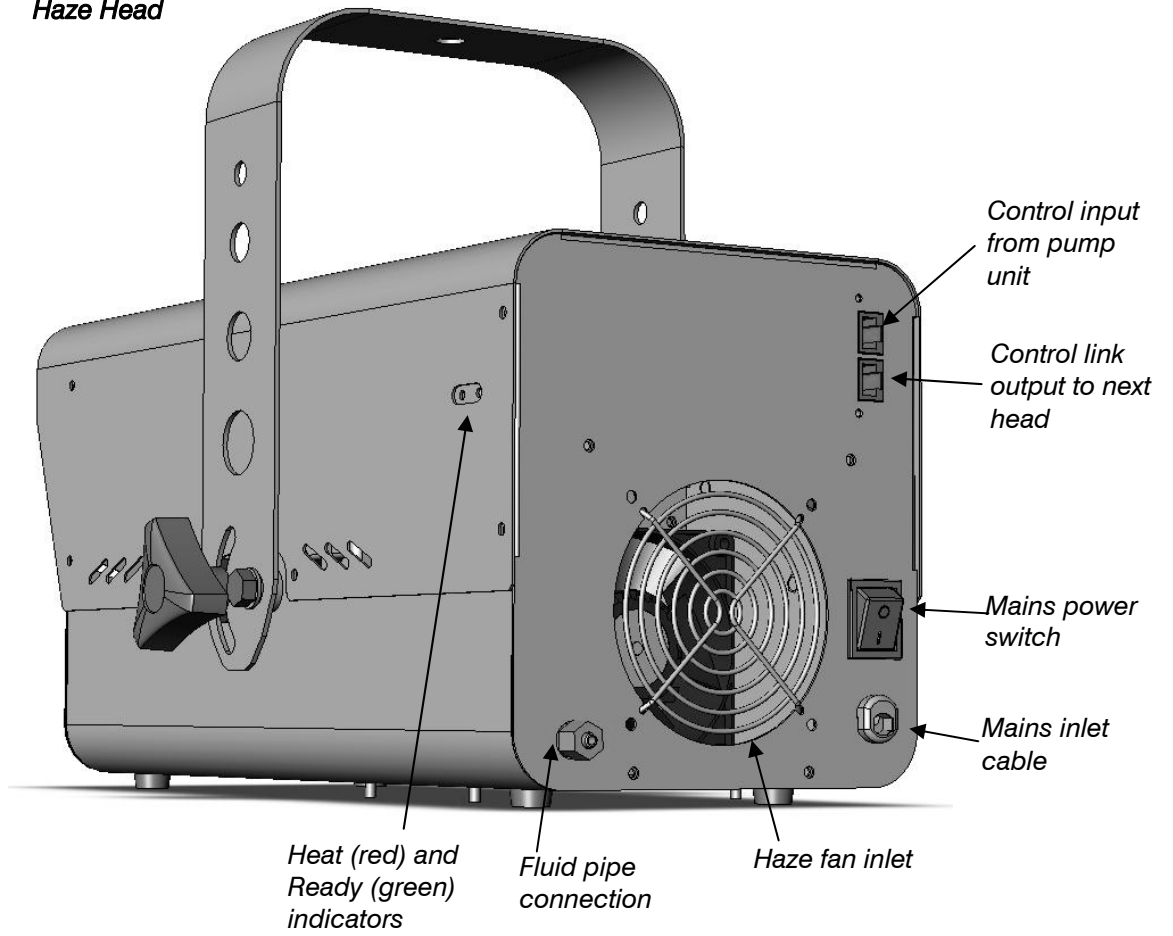

WARNING!
High temperature
vapour and surfaces

Base pump unit

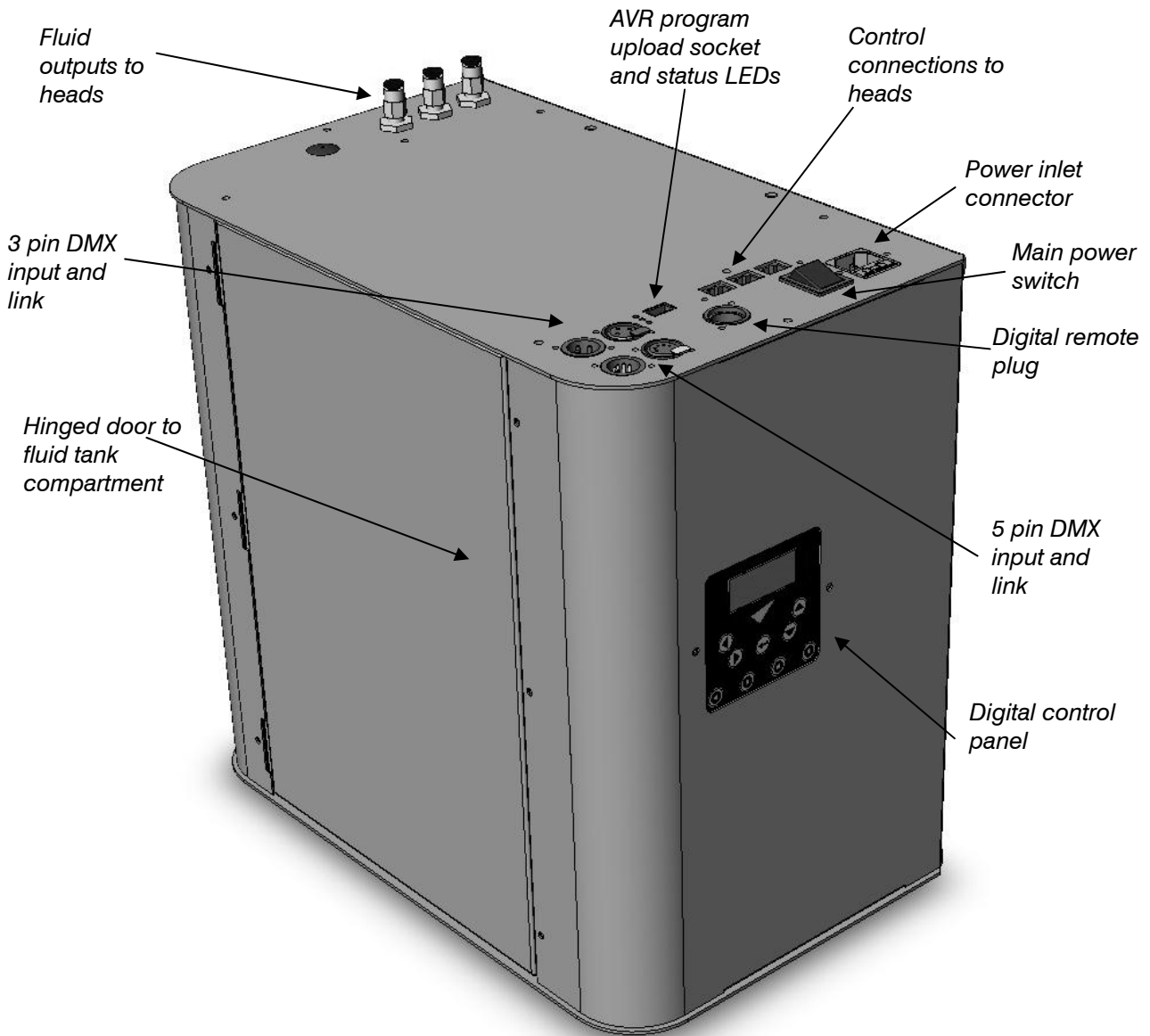

Quick Start

You are no doubt eager to switch on the system and try it out by making a lot of fog. This section tells you how to do that. However, please also make the time to read the safety and servicing instructions in the remainder of this manual.

Setting up

Locate the head(s) in a suitably large area with nothing in front of the fog output.

Connect the fluid pipes from the head units to the base unit. A maximum of 2 heads of the same type (fog or haze) can be connected to each output on the base unit. If you are connecting 2 heads, use a T-connector to link the pipes.

Connect the heads to the base unit with RJ45 cables. If you are connecting 2 heads to an output, the second head is linked from the first.

Fill the fluid tank in the base unit with RUSH Club Smoke Dual Fluid™ only. Use of other fluid will void the warranty.

Connect a suitably rated power supply to the heads and to the base unit using the supplied IEC cable. The power requirements are:

Base unit

0.9 A @ 230 V (EU model)

1.7 A @ 120 V (US model)

Fog Heads

5.1 A @ 230 V (EU model)

8.6 A @ 120 V (US model)

Haze Heads

4.0 A @ 230 V (EU model)

7.6 A @ 120 V (US model)

Now set the mains switches, on the rear of each head and on the top of the base unit, to the 'ON' position. The display will show **HEAT**. If the display shows **OFF** use the menu panel to set the RUNF option to **CONT**. After about 6-8 minutes the display should show **CONT** and the system will begin producing fog. If the display shows **RDY** use the menu panel to set the RUNF option to **CONT** to start fog.

Once the system has heated the first time you will need to prime the pipework using the 4 prime buttons at the bottom of the control panel.

Making fog and haze

If you want to adjust the fog density manually, press the Menu < > buttons until the display shows **FOG**, then press the Enter button and use the Value up/down buttons to select a value above 0%. The Haze density can be adjusted using the **HAZE** menu the same way.

You can also adjust the fan speed using the **FAN** menu.



If no fog is produced it may be necessary to prime the system, press the Menu < > buttons until the display shows **PRME**, then press the Value Up button so the display shows **Y**, then press the Enter button.

Installation and setting up



DANGER! DO NOT operate the system until you have read and observed all the precautions listed under “Safety information” on page 5.

Location

The RUSH Club Smoke Dual™ heads are designed to be located on the floor or may be suspended using the fitted flying bracket. The heads can operate in any orientation from vertically down to vertically up. They must not be used upside down.

If the heads are to be suspended, ensure the mounting surface can support the weight of the head. Do not suspend the heads over areas where people will be underneath. Use only the fitted flying bracket to suspend the head.

Ensure that there is at least 100mm clearance all-round the head and at least 60cm in front of the fog output.

The base pump unit can be located in any convenient location, but must be within 10m of the furthest haze head or 50m of the furthest fog head. It must be the lowest point of the system and not more than 10m below the highest head. Keep 150mm clearance around the unit and 300mm above the unit.

AC power

Before using the system, ensure that a grounding-type (earthed) power plug that fits the local power outlets is installed on the IEC cable provided and on the mains cable of each head.



DANGER! Make sure the power plug is correctly rated:

- For EU (230 V) use fit a plug rated 6 amps minimum
- For US (120 V) use fit a plug rated 10 amps minimum

When installing the plug, follow the plug manufacturer’s instructions and connect pins as follows:

Yellow and green wire to ground (earth), blue wire to neutral and brown wire to live.

The table below shows some common pin identification schemes.

wire	function	marking	screw colour
brown	live	“L”	yellow or brass
blue	neutral	“N”	silver
green/yellow	earth		green

Before connecting the system to power, verify that the AC supply is adequately dimensioned for the current draw of the system.

Base unit

0.9 A @ 230 V (EU model)

1.7 A @ 120 V (US model)

Fog Heads

5.1 A @ 230 V (EU model)

8.6 A @ 120 V (US model)

Haze Heads

4.0 A @ 230 V (EU model)

7.6 A @ 120 V (US model)

Check that the local AC voltage is appropriate, as indicated on the system's serial number label. If your AC voltage is outside the appropriate range, do not use the system. Contact Martin Service for assistance.

Setting up

Fill the fluid tank only with Martin RUSH Club Smoke Dual Fluid™ (see page 25).

Up to two heads of the same type (fog or haze) may be connected to each fluid output of the pump unit. Push the fluid tubing into the connections on the head and the pump unit and secure on the heads using the locking screw. If two heads are being connected to an output, a T-connector must be fitted in the fluid tubing.



It is recommended that if you are using Haze heads you should connect them to channel 1

Connect the RJ45 control connection on the heads to the pump unit. If two heads are being connected to a channel, use the RJ45 link output on the first head to connect the second head. The RJ45 connectors are linked together internally and either can be used as input or link.

Connection of single head

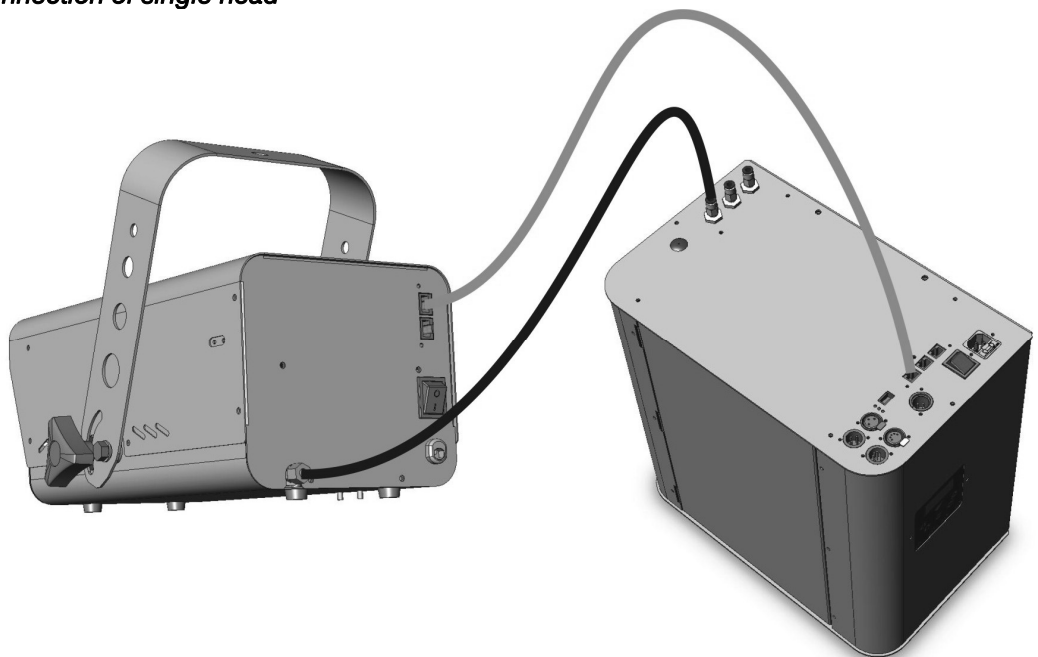

Connection of two heads on one channel

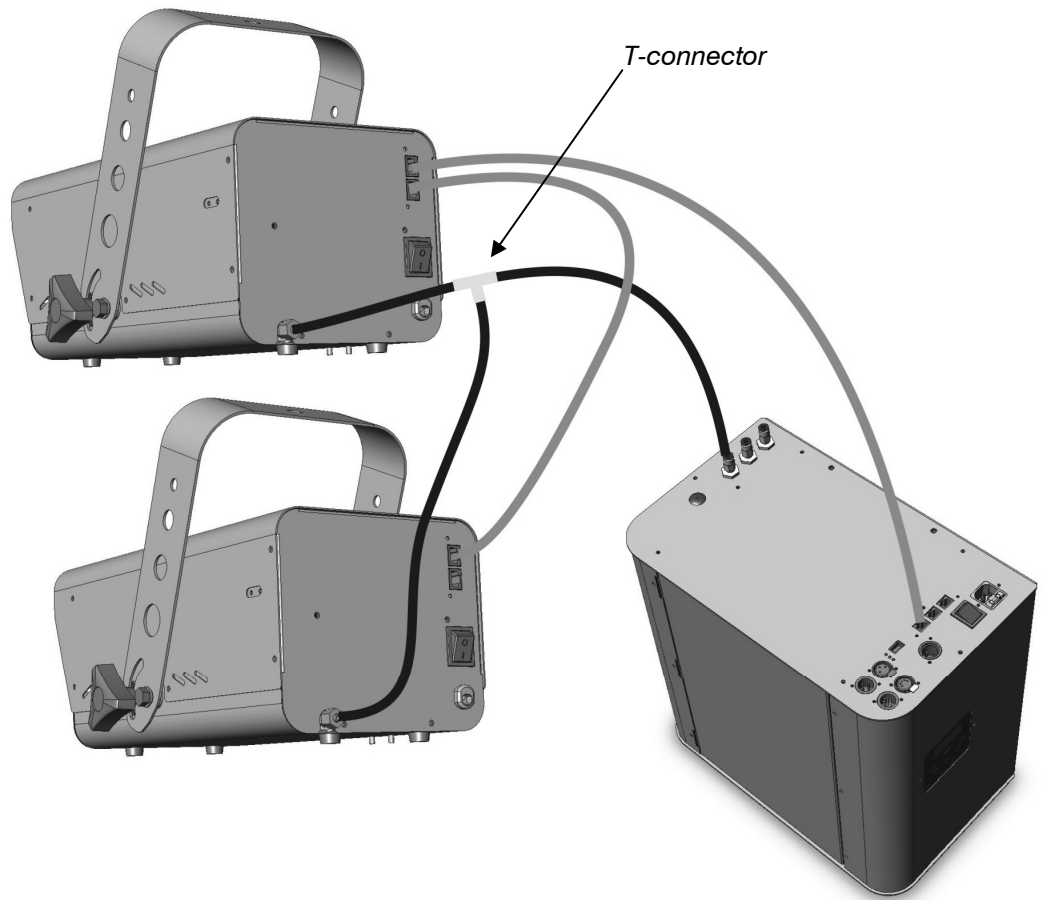

Connection of fully loaded system

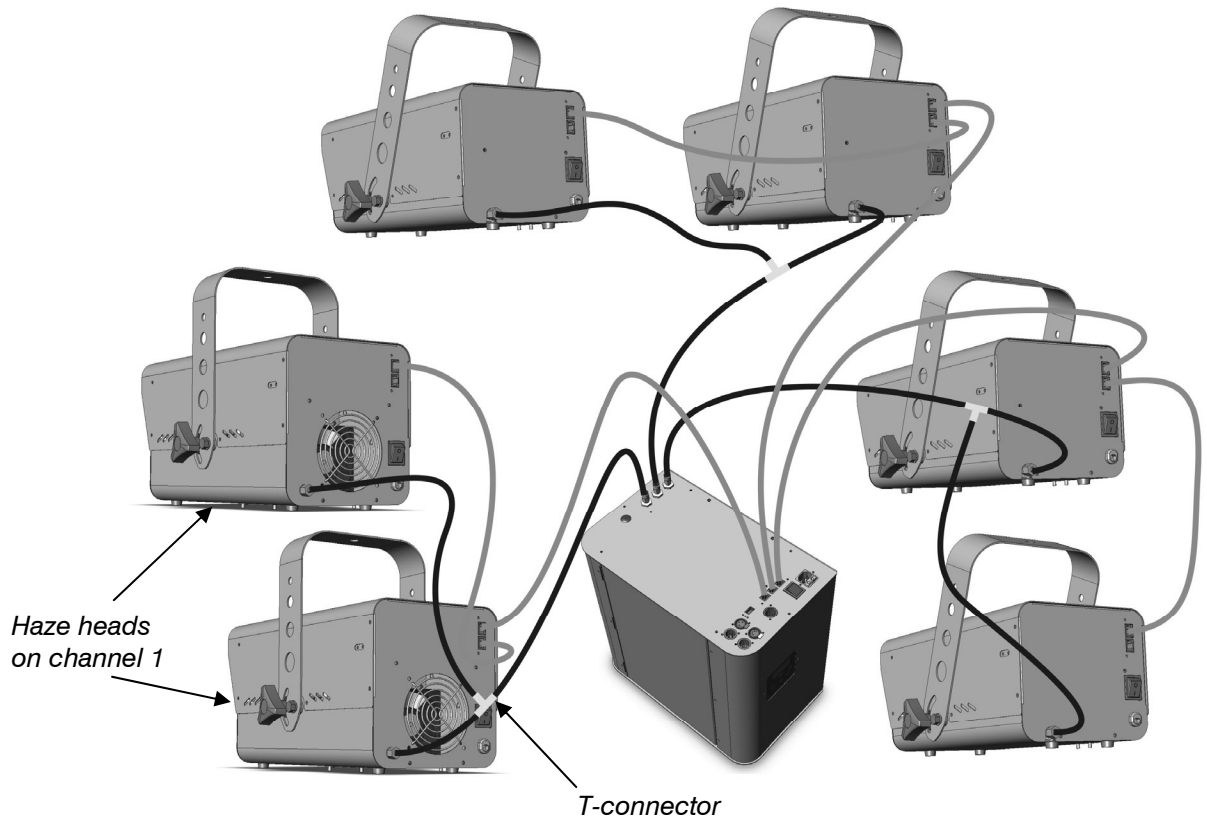

If DMX control is being used, connect the base unit to the DMX line (see page 18). If the Digital Remote is being used (optional accessory), connect the remote to the Remote socket (see page 9).

Final checks

Before applying power to the system, verify the following:

- the system is safely located or installed and meets the location requirements stated on page 13
- the operator is familiar with, and able to comply with, the requirements for safe operation listed on page 5.
- the fluid is one of the genuine Martin fluids listed under “Fluid options” on page 25.
- the system is electrically grounded (earthed)
- the AC power distribution circuits and lines are adequately rated for the current load

Turning on the power

Ensure the power switch on each head is turned on. Turn on the main power switch on the base unit located next to the power inlet. The display will show **HEAT**. If the display shows **OFF**, go to the **RUNF** menu on the digital control panel and set the option to **CONT**. The system will remember its state from when it was turned off last time, so it will only power up in **OFF** mode if you have previously disabled the heaters.

After about 6-8 minutes if no DMX is connected the display should show **CONT** and the system will begin producing fog. If the display shows **RDY** go to the **RUNF** menu and set the option to **CONT** to start fog. If DMX is connected the display will show **DMX** when the system is ready.

Each head has a red and green light on the side to indicate heating status:

RED: Heating

GREEN: Ready

Once the Ready light has come on, the head will continue to heat for a time, and the heater will cycle on and off to maintain the temperature.



The first time you run the system after connecting fluid pipes you will need to prime the system. See section “Priming system with Quick access buttons” on page 19.

Control settings

Overview

The **digital display** on the side of the base unit allows you to configure the system using option menus.

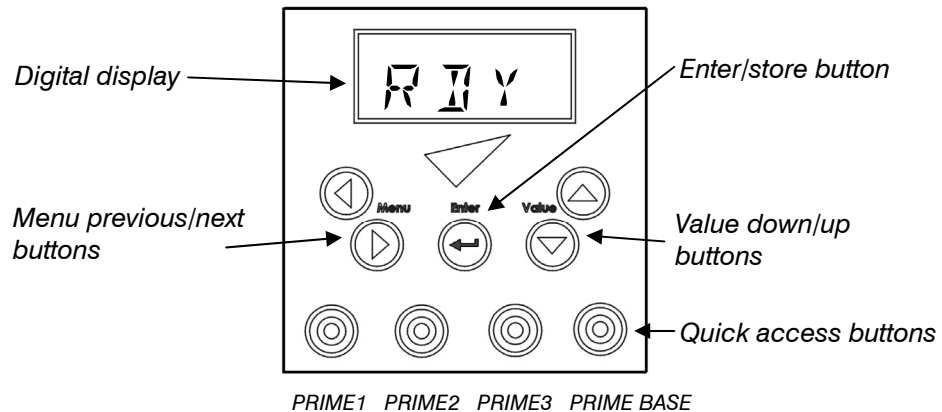

The brightness of the display can be changed to **LOW**, **NORM** or **HIGH** using the **DISP** menu option.

Setting Fog Run modes

The **RUNF** menu sets the operational mode of the Fog heads in the system, and can also be used to shut down the heaters in the heads. Settings are **Off** (shutdown, heaters off), **Standby** (heaters remain on), **Timer mode** or **Continuous mode**.

Use the **Menu Previous / Next** buttons to select the **RUNF** option.
Use the **Up/Down** buttons to select **OFF**, **STBY**, **TIME**, **CONT**.
Press the **Enter** button to store the setting. The display shows **SET**.

Selecting **OFF** will disable the heaters on the unit.

Setting output density for Fog heads

Use the **Menu Previous / Next** buttons to select the **F D E** option.
Use the **Up/Down** buttons to select the density from **0%** – **100%**.
Press the **Enter** button to store the fog setting. The display shows **SET**.



If you want to temporarily change the fog density, do not press **Enter**. The fog setting will go back to its stored value next time the system is powered up. This applies to all options.

Setting Haze Run modes

The **RUNH** menu sets the operational mode of the Haze heads in the system, either **Standby**, **Timer mode** or **Continuous mode**.

Use the **Menu Previous / Next** buttons to select the **RUNH** option.

Use the Up/Down buttons to select **S T B Y**, **T I M E**, **C O N T**.
Press the Enter button to store the setting. The display shows **S E T**.

Setting output density for Haze heads

Use the Menu Previous / Next buttons to select the **H F Z E** option.
Use the Up/Down buttons to select the density from **0%** – **100%**.
Press the Enter button to store the haze setting. The display shows **S E T**.

Setting the Timer

Select the **T I M E** option from the **R U N** menu.
Then set the **T R U N** and **T O F F** values from the menu.
The **T R U N** and **T O F F** values are set in seconds and are in the range 0-99. The Fog and Haze values are taken from the menu settings for Fog and Haze. The timer will cycle continuously until the run menu is changed.
Use this mode for maintaining a low level of fog in smaller venues.



When the timer is running and the display is not showing a menu, the display shows **T R U N** or **T O F F** as the timer cycles between run and off modes.

Setting the DMX base address

Use the Previous / Next buttons to select the **F I I R** option.
Use the Up/Down buttons to set the DMX base address from **001** to **509**. If you hold down the button the address will count up or down.
Press the Enter button to store the address setting.
The system will automatically respond to a DMX controller whenever it is connected.

When using in a DMX system ensure the **L I N K** menu is set to **R E C V** (the default setting) to avoid causing DMX errors to other devices on the system.

Setting the master-slave link mode

It is possible to control several systems from one digital remote. The system with the remote plugged into it becomes the Master. The other systems are Slaves. The systems are interconnected with DMX cabling.

Use the Previous / Next buttons to select the **L I N K** option.
Use the Up/Down buttons to select **R E C V** (slave unit) or **S E N I** (master unit).
Press the Enter button to store the link setting.

The system should be set to **S E N I** only if it is running as a master. If running as a slave, stand-alone or DMX controlled it should be set to **R E C V**. If a system set to **S E N I** is connected to an active DMX system, the DMX will be corrupted causing flickering of lights and other strange symptoms.

Priming the system after fluid out

If the system runs out of fluid it will automatically shut down and show **F L U O U T** on the display to prevent damage to the pump. To suck the new fluid back into the system and reset the **F L U O U T** error, replace/refill the fluid tank and use the prime function.

- To prime the pipework in between the pump units and the heads after installation, use the 4 quick access buttons below the display to prime outputs 1, 2, 3 or the base independently. See next section.

Use the Previous / Next buttons to select the **PRIME** option.

Use the Up/Down buttons to change the option to **Y**.

Press the Enter button to start the priming function.

The pump unit will pump at full power for a short time to purge air from the pipes inside the unit.

To exit this menu if you decide not to activate the Prime function, select **N** and press Enter.

Priming system with Quick access buttons

The four quick access buttons below the display are used for priming the system output rate.

The three left hand buttons will prime the outputs to heads 1, 2 and 3 independently. This is used to expel air from the pipes between the pump unit and the heads after installation. Priming continues while the buttons are held down and stops when the buttons are released.



The heads must be in “Ready” state for the output prime function to operate. Keep the button held down until fog/haze is produced from the head.

The right hand button runs a timed sequence to prime the base unit and is normally used when replacing fluid. This will also reset the Fluid Out error. The heads do not need to be in “Ready” state for the base prime function to work, and no fog/haze will be produced.

Resetting options to factory settings

The factory settings configure a standard mode of operation for the system.

Use the Previous / Next buttons to select the **RESET** option.

Use the Up/Down buttons to change the option to **Y**.

Press the Enter button to reset all options.

To exit this menu if you decide not to reset the options, select **N** and press Enter.

The factory settings are:

option	setting
FOG	10%
HAZE	10%
TRUN	10 seconds
TOFF	20 seconds
RUNF	OFF
RUNH	OFF
ADDR	001
DISP	NORM
LINK	RECV
PRME	N

Remote control

Overview

The digital remote control, available separately, may be used for remote control of the RUSH Club Smoke Dual™. Several systems may be controlled from one remote using the LINK function (see page 18).

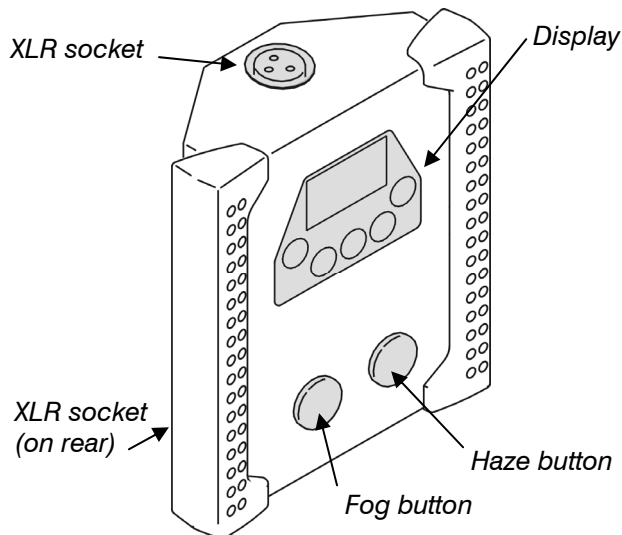

Functions

The remote control provides the following functions:

- *Fog button*: turns fog head output on and off. Press once to start output from fog heads and again to stop.
- *Haze button*: turns haze head output on and off. Press once to start output from haze heads and again to stop..
- *Fog level setting* (FOG = 0 -100%)
- *Haze level setting* (HAZE = 0 -100%)
- *Timer run time/off time settings* (TRUN = 0 -99 seconds, TOFF = 0-99 seconds)
- *RunF* – run mode for fog heads (RUN = OFF, STBY, TIME, CONT)
- *RunH* – run mode for haze heads (RUN = STBY, TIME, CONT)

The functions are the same as on the built in control panel and are described on page 13.

The **RUN** menu duplicates the functions of the Fog and Timer buttons. The buttons are simply a quick way to control this menu function.

Connection

The remote control has two identical XLR connectors on the top and back for connection to the RUSH Club Smoke Dual™ system. The back connector allows the remote to be mounted into a panel or console. Plug the cable provided with the remote control into either of these sockets and into the 3-pin XLR plug nearest the mains switch on the top panel of the base pump unit (not the 3-pin DMX plug).

*The remote control is powered through its cable by the RUSH Club Smoke Dual™; no batteries are required.
The cable may be extended to up to 25 m (82 ft.) with a 3-pin XLR DMX cable, available from your Martin dealer.*

DMX control

Overview

DMX is a digital control system widely used in entertainment and architectural lighting. Any controller meeting the DMX-512 standard may be used to control and program the fog output of the RUSH Club Smoke Dual™.



When a DMX signal is present, the RUSH Club Smoke Dual™ stand-alone functions do not work. To fire the unit from the control panel or remote control, the DMX controller must be powered off or disconnected.

Connection

The RUSH Club Smoke Dual™ system provides 3-pin and 5-pin XLR connectors on the top of the base pump unit for DMX connection.

You can use either the 3-pin or 5-pin connectors for in or link through, but you should not use the unit as a splitter by connecting both the 3-pin and 5-pin outputs.

For best results, use cable designed for high speed digital data transmission. Suitable DMX cable is available from your Martin dealer.

DMX functions

The RUSH Club Smoke Dual™ address setting must match the DMX address allocated to it on your controller. To set the address, see “Setting the DMX base address” on page 18. The RUSH Club Smoke Dual™ requires four DMX channels.

For example if the RUSH Club Smoke Dual™ is set to DMX address 100, channel 1 will be controlled by address 100, channel 2 will be controlled by address 101, channel 3 by address 102 and channel 4 by address 103.

When the system is at running temperature and is under DMX control it displays **DMX**.

The functions of each DMX control channel are shown on the following page.

Channel 1	DMX value range	Function	Macro description	Default value
<i>Fog/haze output 1 level</i>	0-12	<i>Idle range</i>	<i>None</i>	<i>0</i>
	13- 240	<i>Output 0-100%</i>		
	241 -255	<i>Output 100%</i>		
Channel 2	DMX value range	Function	Macro description	Default value
<i>Fog/haze output 2 level</i>	0-12	<i>Idle range</i>	<i>None</i>	<i>0</i>
	13- 240	<i>Output 0-100%</i>		
	241 -255	<i>Output 100%</i>		
Channel 3	DMX value range	Function	Macro description	Default value
<i>Fog/haze output 3 level</i>	0-12	<i>Idle range</i>	<i>None</i>	<i>0</i>
	13- 240	<i>Output 0-100%</i>		
	241 -255	<i>Output 100%</i>		
Channel 4	DMX value range	Function	Macro description	Default value
<i>Special functions</i>	0-50	<i>Idle range</i>	<i>None</i>	<i>0</i>
	51-100	<i>Prime base station</i>	<i>5 seconds within range to activate once</i>	
	101-150	<i>Not used</i>		
	151-200	<i>Heater off & shutdown</i>	<i>5 seconds within range to activate once</i>	
	201-255	<i>Heater on (normal operation)</i>	<i>None, but heaters will stay on if channel 4 returns to zero</i>	

Fog fluid types

The RUSH Club Smoke Dual™ must only be used with RUSH Club Smoke Dual Fluid™. Martin supplies high quality fog fluids that are based on ultra-pure deionized water. No other fluid is suitable for use.

To find your local dealer visit www.martin.com



DANGER! The RUSH Club Smoke Dual™ can run safely only on the specific fog fluid it is designed for. Use **ONLY** the Martin fog fluid designated in this manual. **NEVER** use any other type of fluid, or toxic gas may be produced. You will probably also cause damage to the system that will invalidate the product warranty. Do not dilute fog fluid with water or any other liquid. Discard fog fluid if it becomes contaminated.

Basic service



Before servicing the RUSH Club Smoke Dual™, read and observe all the precautions listed in “Safety information” on page 5. Any service not described in this section must be carried out by a Martin service technician.

To find your local Martin service centre visit www.martin.com

Cleaning

Excessive dust, fog fluid, and dirt build-up will degrade performance and cause overheating and damage to the system that is not covered by the product warranty. To maintain adequate cooling, dust must be cleaned from the outer casing and air vents of the system periodically.



Isolate the system from power and allow to cool completely before cleaning. The fog/haze output nozzles remain hot for a period after use.

- Remove dust from the air vents with a soft BRUSH, cotton swab, vacuum, or compressed air.
- Clean fog fluid residues from the fog output of the system using a damp cloth.
- Clean the outer casing with a damp cloth only.

Fuse replacement

The fuses for the system are located on the electronics board inside the units.



DANGER! Disconnect the power supply before removing any covers. Live parts inside!

To replace a fuse, disconnect the power cord from the supply, unscrew the screws holding the top cover of the unit and remove the cover. The electronics board is located in the compartment under the display.

Remove the spent fuse and replace with one of exactly the same size and rating. The fuse type is indicated below. Contact Martin Service if the fuse blows repeatedly.

Fog head

120 V = 10 AT

230 V = 6.3 AT

Haze head

120 V = 10 AT

230 V = 6.3 AT

Pump unit

120 V = 3.15 AT

230 V = 3.15 AT

Troubleshooting

Problem	Probable cause(s)	Suggested remedy
System will not produce fog/haze when control panel set to RUN or remote control Fog/Haze switch turned on	System not at operating temperature	Wait until HEAT message no longer shown
	FOG or HAZE set to 0	Increase setting
	TRUN set to 0	Increase setting
	DMX signal present	Disconnect or turn off DMX controller
System can be fired from control panel or remote control, but not by DMX controller	DMX address setting incorrect	Change DMX address (page 18)
	Poor connection in DMX line	Check DMX cables and connections
	LINK menu is set to SEND	Set LINK menu to RECV
All fog/haze outputs are weak	Base pump unit requires priming	Prime base pump unit (page 18)
Fog/haze output is weak on one particular head	Channel requires priming	Prime the channel (page 18)
Wet, greasy, non-uniform fog output, fluid drips or spits from nozzle, or very loud noise when firing system	Incompatible fog fluid	Use approved fluid!
System appears dead	Mains fuse blown	Replace fuse (page 26)
	No power at AC cable inlet	Check power cable and circuit breaker
System causes DMX errors to occur on other units when connected to a DMX system	LINK menu is set to SEND	Set LINK menu to RECV

Status messages

message	reason
OFF	The heaters are Off, the unit is shut down.
HEAT	The unit is heating up to operating temperature.
RDY	The heater is at operating temperature, but Fog is not turned on (RUN set to STBY or FOG set to 0%).
DMX	The heater is at operating temperature and the unit is under DMX control.
RN13	The system is in Timer mode and is in a RUN period (the number counts down to show the run time)
OF15	The system is in Timer mode and is in an OFF period (the number counts down to show the off time)
FLU ERR	Run out of fluid. Refill the fluid tank and operate the base prime function (bottom right hand button on control display)
CAL ERR	The system has detected an error with its calibration settings and will not operate. Call Martin Service.
TEMP ERR	The system has detected an error in the temperature sensor and will not operate. Call Martin Service.

Resetting the system after fluid out

If the system runs out of fluid simply refill the fluid container and follow the priming instructions on page 18.

Specifications

Physical

Fog head
Length 356 mm
Width 259 mm
Height..... 169mm (278mm including hanging bracket)
Dry weight 7.6 kg

Haze head
Length 395 mm
Width 259 mm
Height..... 209mm (318mm including hanging bracket)
Dry weight 8.9 kg

Pump unit
Depth..... 257 mm
Width 415 mm
Height..... 431 mm
Dry weight 13.4 kg

Performance

Operating time..... continuous
Warm up time (approx)..... 7 minutes
Haze maximum operating time at maximum output with 10L fluid 15.9 hours
Fog maximum operating time at maximum output with 10L fluid 2.8 hours

Control and programming

Control options onboard control panel, DMX, optional digital remote control
..... instant or timer-controlled output, 0-100% adjustable output level
DMX channels 4
DMX compliance USITT DMX512-A

Construction

Housing Steel & aluminium
Heat exchangers (fog head)..... 1150 W EU, 1000 W US, direct thermal protection
Heat exchangers (haze head) 900 W, direct thermal protection

Fluid system

Fluid pump Oscillating piston, high pressure
Onboard fluid capacity..... 10 litres (2.64 US gal.)
Compatible fluids RUSH Club Smoke Dual fluid

Installation

Orientation..... Floor or flying kit
Max distance from pump unit to fog heads..... 50 m
Max distance from pump unit to haze heads 10 m
Max height difference between pump units and heads 10 m

Connections

Power connection (base) IEC
Power connection (heads) Hardwired

DMX data 3-pin and 5-pin XLR sockets
Remote control 3-pin locking XLR

Electrical

AC power (EU models) 220-240 V nominal, 50/60 Hz
AC power (US models) 115-125 V nominal, 50/60 Hz
Main fuse in heads (220-240V power) 6.3A T/250 V
Main fuse in heads (110-120V power) 10 AT/125 V
Main fuse in base pump unit 3.15 AT/250 V

Typical Power and Current

Fog head (EU model) 1150 W, 5.1 A
Fog head (US model) 1000 W, 8.6 A
Haze head (EU model) 900 W, 4.0 A
Haze head (US model) 900 W, 7.6 A
Base pump unit (EU model) 180 W, 0.9 A
Base pump unit (US model) 180 W, 1.7 A
Measurements made at nominal voltage. Allow for a deviation of +/-10%

Thermal

Maximum ambient temperature (Ta max) 40°C (104°F)
Exterior surface temperature, steady state, at 20°C ambient 30°C (86°F)
Max nozzle temperature 290°C (554°F)

Approvals



EU EMC: EN 61000-6-3:2007
EU safety: EN 60335-1:2002 + A15:2011
Immunity: EN 61000-6-1:2007
..... EN 62233:2008 Electromagnetic fields
US safety (pending) UL998
Canadian safety (pending) CSA C22.2 No 104

Included items:

Fog head

- Fast-in 'T' connector*
- Patch lead, CAT 5E, 10 m (32.8 ft)*
- Fluid line 10 m (32.8 ft)*

Haze head

- Fast-in 'T' connector*
- Patch lead, CAT 5E, 10 m (32.8 ft)*
- Fluid line 10 m (32.8 ft)*

Pump unit

- Fluid container, 10 l (2.64 US gal.)*
- Power cable, 1.5 m (4.9f t.), IEC to stripped ends (230 V)*
- Power cable, 1.5 m (4.9 ft.), IEC to NEMA 5-15P plug (115 V)*

Accessories

Multifunction Digital Remote Control, RUSH Club Smoke Dual™P/N 92765043
External fluid kit optionP/N 92620030

Ordering information

Pump unit RUSH Club Smoke Dual™ US model 120VP/N 92250140
Pump unit RUSH Club Smoke Dual™ EU model 230VP/N 92250130
Fog head RUSH Club Smoke Dual™ US model 120VP/N 92250160
Fog head RUSH Club Smoke Dual™ EU model 230VP/N 92250150
Haze head RUSH Club Smoke Dual™ US model 120VP/N 92250180
Haze head RUSH Club Smoke Dual™ EU model 230VP/N 92250170

Specifications subject to change without notice. For the latest product specifications, see www.martin.com

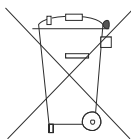

Disposing of this product

Martin™ products are supplied in compliance with Directive 2002/96/EC of the European Parliament and of the Council of the European Union on WEEE (Waste Electrical and Electronic Equipment), as amended by Directive 2003/108/EC, where applicable.

Help preserve the environment! Ensure that this product is recycled at the end of its life. Your supplier can give details of local arrangements for the disposal of Martin products.



*www.martin.com • Olof Palmes Allé 18 • 8200 Aarhus N • Denmark
Tel: +45 8740 0000 • Fax: +45 8740 0010*