

Mania SCX600/700

user manual



Martin

DIMENSIONS

All dimensions are in millimeters

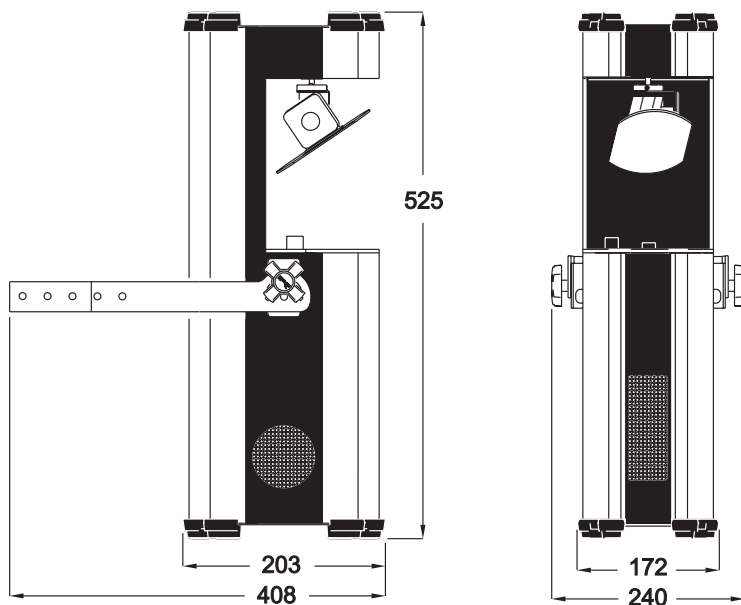

©2005-2009 Martin Professional A/S, Denmark.

Martin Professional A/S. Information subject to change without notice. Martin Professional A/S and all affiliated companies disclaim liability for any injury, damage, direct or indirect loss, consequential or economic loss or any other loss occasioned by the use of, inability to use or reliance on the information contained in this manual. The Martin logo, the Martin name and all other trademarks in this document pertaining to services or products by Martin Professional A/S or its affiliates and subsidiaries are trademarks owned or licensed by Martin Professional A/S or its affiliates or subsidiaries.

P/N 35000169, Rev. F

Contents

Introduction	5
Unpacking	5
Mania SCX600/700 overview	6
Safety information	7
Installation	9
AC power	9
Rigging the fixture	10
Creating a data link for DMX or synchronized operation	11
Operation	14
Getting started	14
Music trig, auto trig and DMX modes	15
Synchronized music trig and auto trig operation	16
DMX controller operation	17
Focus adjustment	20
Adjusting music level sensitivity	20
Control panel	21
Movement	21
Mania SCX700 dimming	21
Information readouts	21
Manual control	22
Effects test	23
Upload mode	23
Service and maintenance	24
SCX600 lamp	24
SCX700 lamp	26
Cleaning	27
Replacing the main fuse	28
Replacing a color filter	29
Rotating gobos	30
Mirror removal	32
Error messages	32
Software uploads	33
Troubleshooting	34
SCX600 DMX protocol	35
SCX700 DMX protocol	38
Control menus	41
Circuit board layouts	43
Mania SCX600/700 specifications	45

This page left intentionally blank

1. INTRODUCTION

Thank you for selecting a fixture from the Martin Mania SCX600/700 series. This series of automated moving-mirror projectors has the following features:

- 9 full colors plus white
- 7 interchangeable rotating gobos including 2 glass gobos (SCX600) or 3 glass gobos (SCX700)
- 198° pan and 72° tilt
- Adjustable focus
- DMX control with two DMX modes: DMX mode 2 gives extended functionality on additional channels
- Auto triggering and music triggering modes
- Stand-alone single fixture and synchronized (master/slave) modes
- Professionally designed pre-programmed effects macros
- Rotating gobo indexing (SCX700 only)
- Long-life 250 Watt halogen lamp (SCX600)
- Long-life 150 Watt discharge lamp (SCX700)

Unpacking

The packing material is carefully designed to protect the fixture during shipment - always use it to transport the fixture.

The Mania SCX600/700 is supplied with:

- Lamp (the SCX700 discharge lamp is supplied separately to avoid damage during shipping and must be installed before use – see “*Installing the SCX700 lamp*” on page 26)
- Power cable and 5 meter (16.4 ft.) RS-485 XLR cable for data link
- User manual
- Mounting U-bracket with fasteners
- Allen key

Important! The mirror assembly is secured for transport. Before applying power, remove all transport packaging, remove the protective film from the mirror and cut and remove all plastic tie-wraps holding the mirror!

Mania SCX600/700 overview

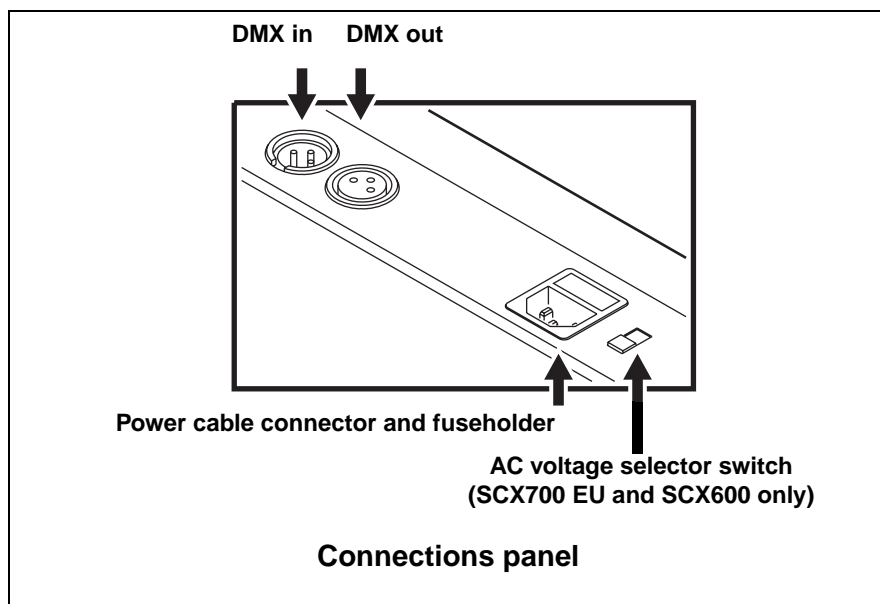
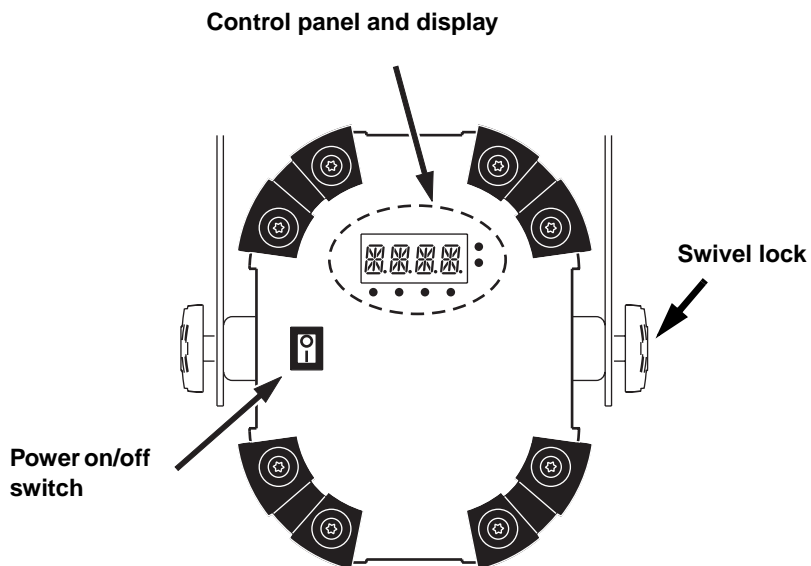

Safety information

Warning! *This product is for professional use only. It is not for household use.*

This product presents risks of lethal or severe injury due to fire and heat, electric shock, ultraviolet radiation, lamp explosion, and falls. **Read this manual** before installing or powering the fixture, follow the safety precautions listed below and observe all warnings in this manual and on the fixture. If you have any questions about how to operate the fixture safely, please contact your Martin dealer or call the Martin 24-hour service hotline.

Protecting yourself and others from electric shock and injury

- Disconnect the fixture from AC power before removing or installing the lamp, fuse, or any part, and when not in use.
- Always ground (earth) the fixture electrically.
- Do not use the fixture with a damaged power cable or cord cap (mains plug).
- Use only a source of AC power that complies with local building and electrical codes and has both overload and ground-fault protection.
- Do not expose the fixture to rain or moisture.
- Refer all service not described in this manual to a Martin service technician.
- Never operate the fixture with missing or damaged lenses.
- Glass lenses must be changed if they have become visibly damaged to such an extent that their effectiveness is impaired, for example by cracks or deep scratches.
- Never operate the fixture if covers are open or if any component is missing, damaged or deformed: an unshielded discharge lamp emits dangerous UV radiation that can cause burns and eye damage.
- Protect your hands and eyes with gloves and safety glasses when changing the lamp.
- Do not stare directly into the light output. Never look at an exposed lamp while it is lit.
- Replace the lamp if it becomes defective or worn out.

Protecting yourself and others from burns and fire

- Never attempt to bypass the thermostatic switch or fuses. Always replace defective fuses with ones of the specified type and rating.

- Keep all combustible materials (for example fabric, wood, paper) at least 0.1 meters (4 inches) away from the fixture. Keep flammable materials well away from the fixture.
- Do not illuminate surfaces within 1 meter (3.3 feet) of the fixture.
- Provide a minimum clearance of 0.1 meters (4 inches) around fans and air vents.
- Never place filters or other materials over the lens or mirror.
- Allow the fixture to cool before handling. Allow the fixture to cool for at least 20 minutes before opening the fixture or removing the lamp.
- Do not modify the fixture or install other than genuine Martin parts.
- Do not operate the fixture if the ambient temperature (T_a) exceeds 40° C (104° F).

Protecting yourself and others from injury due to falls

- When suspending the fixture above ground level, verify that the structure can hold at least 10 times the weight of all installed devices.
- Verify that all external covers and rigging hardware are securely fastened and use an approved means of secondary attachment such as a safety cable.
- Block access below the work area and work from a stable platform whenever installing or removing the fixture.

2. INSTALLATION

AC power

The Mania SCX600/700 is supplied set up to match local voltage and frequency settings. The factory setting is shown on the serial number label.

Warning! *For protection from fire and electric shock, the fixture must be grounded (earthed). The power supply must have overload and ground-fault (earth-fault) protection.*

Check that power cables are undamaged and rated for the current requirements of all connected devices before use.

Ensure that the fixture's voltage setting matches your local AC power supply before applying power.

Important! *Do not connect the fixture to a dimmer system, as this will cause damage that is not covered by the product warranty.*

Mania SCX600 power settings

All Mania SCX600 models can be set to 115 V, 60 Hz or 230 V, 50 Hz AC power using the switch on the connections panel.

- Set the switch to 115 V if you have 110-120 V, 60 Hz AC power.
- Set the switch to 230 V if you have 220-240 V, 50 Hz AC power.

Mania SCX700 power settings

- Mania SCX700 EU models can be set to 230 or 240 V, 50 Hz AC power using the switch on the connections panel. Use the 230 V setting if you have 220-230 V power, and use the 240 V setting if you have 230-240 V.
- Mania SCX700 US models do not have a switch and are supplied set up for 110-120 V, 60 Hz AC power.

Installing a cord cap on the power cable

The power cable must be fitted with a grounding-type cord cap (earthed mains plug) that matches your AC power distribution system. Consult a qualified electrician if you have any doubts about proper installation.

If you need to fit a cord cap, follow the cord cap manufacturer's instructions, connecting the yellow and green wire to ground (earth), the brown wire to live, and the blue wire to neutral. The table below shows some pin identification schemes:

Wire	Pin	Marking	Screw color
brown	live	"L"	yellow or brass
blue	neutral	"N"	silver
yellow/green	ground		green

Table 1: Cord cap wiring

Rigging the fixture

The Mania SCX600/700 must be mounted by means of its adjustable U-bracket. Do not install the fixture by any other means, as this can cause the fixture to overheat.

The U-bracket can be either fastened to a flat surface or attached to a rigging clamp. Suitable rigging clamps are available from your Martin dealer.

Warning! *Block access below the work area and work from a stable platform when installing or servicing the fixture.*

Do not operate the fixture without fastening it securely to a structure or surface.

Always use a secure means of secondary attachment that can hold at least 10 times the weight of the fixture.

1. The fixture must be located at least 1 meter (3.3 ft.) away from the surface to be illuminated and at least 0.1 meters (4 in.) from any combustible materials (wood, fabric, paper, etc.). Ensure that the clearance around the fan and air vents is at least 0.1 meters (4 in.). Ensure that there are no inflammable materials nearby.

2. If using a rigging clamp, ensure that the clamp is undamaged and can bear at least 10 times the fixture's weight. Bolt the clamp securely to the fixture's mounting bracket with a grade 8.8 (minimum) M12 bolt and lock nut through the 13 mm hole in the center of the mounting bracket, or as recommended by the clamp manufacturer.
3. If fastening the fixture directly to a mounting surface, ensure that any fasteners used and the mounting surface can bear at least 10 times the fixture's weight. The fixture may be fastened using any of the following:
 - four 6.5mm holes in the sides of the U-bracket
 - two 8mm holes in the top of the U- bracket
 - one 13mm hole in the top of the U-bracket.
4. Ensure that the structure used to support the fixture can support at least 10 times the total weight of all installed fixtures, clamps, cables, auxiliary equipment, etc.
5. Install a safety wire that can hold at least 10 times the weight of the fixture through/over the support and through a safety wire attachment point next to one of the swivel locks on the fixture (see illustration).

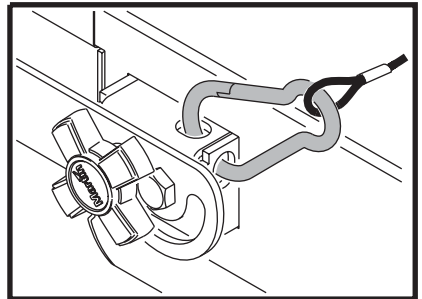

Safety wire attachment point

Important! Do not simply attach the safety wire to the mounting bracket, as this will leave the fixture unsecured.

6. Loosen the swivel locks and tilt the fixture to the desired angle. Turn the swivel locks clockwise to tighten. Check that both swivel locks are tight and that the fixture is securely clamped in position.

Creating a data link for DMX or synchronized operation

You need a serial data link to:

- run light shows on one or more fixtures using a DMX controller, or
- run synchronized light shows on two or more fixtures (master/slave operation).

Fixtures on a serial data link must be daisy-chained in one single line, max. 500 meters (1640 ft.) long, with max. 32 fixtures. If you wish to

exceed 32 fixtures or 500 meters, or to add branches, use an optically isolated amplifier-splitter such as the Martin RS-485 Opto-Splitter (P/N 90758060).

Reliable data connection requires suitable cable. Standard microphone cable cannot transmit DMX data reliably over long runs. For best results, use cable with at least one twisted pair specifically designed for RS-485 applications. Your Martin dealer can supply suitable high quality cable in various lengths.

Connecting the serial data link

The fixture's data connections are XLR type, wired with pin 1 to ground, pin 2 to signal - (cold), and pin 3 to signal + (hot). This is the standard configuration for DMX devices.

One or more adaptor cables may be required to connect the Mania SCX600/700 to the controller and/or other types of fixture, because some devices may have 5-pin XLR connectors, and others may have reversed signal polarity (pin 2 hot and pin 3 cold). Connector polarity is normally specified on the device or in the device's user manual.

5-pin to 3-pin Adaptor		3-pin to 5-pin Adaptor		3-pin to 3-pin Phase-Reversing Adaptor		Male DMX Termination Plug	Female DMX Termination Plug
Male	Female	Male	Female	Male	Female	Male XLR	Female XLR
1 — 1	1 — 1	1 — 1	1 — 1	1 — 1	1 — 1	1	1
2 — 2	2 — 2	2 — 2	2 — 2	2 — 3	2 — 2	2 $\frac{1}{2}$ 120 Ohm	2 $\frac{1}{2}$ 120 Ohm
3 — 3	3 — 3	3 — 2	3 — 3	3 — 1	3 — 3	3 $\frac{1}{2}$ 120 Ohm	3 $\frac{1}{2}$ 120 Ohm
4		4	4				
5		5	5				
P/N 11820005		P/N 11820004		P/N 11820006		P/N 91613017	P/N 91613018

DMX connectors and polarity

To connect the data link:

1. Power all devices off.
2. If you intend to use a DMX controller, run a data cable from the DMX controller's data output to the first fixture's data IN socket. If the controller has a 5-pin output, use a 5-pin male to 3-pin female adaptor cable (available from your Martin dealer: P/N 11820005).
3. If you intend to run fixtures in master/slave operation, insert a female DMX termination plug (P/N 91613018) in the first fixture's data IN socket.

4. Plug a data cable into the OUT socket of the first fixture and the IN socket of the next one. Continue connecting up to 32 fixtures output-to-input.
5. Terminate the link by inserting a male termination plug (P/N 91613017) into the data output of the last fixture. A termination plug is simply an XLR connector with a 120 Ohm, 0.25 W resistor soldered across pins 2 and 3.

3. OPERATION

Note: *The Mania SCX600/700 is supplied in DMX mode with its DMX address set to 1. If want to operate the fixture without a DMX controller, you need to set the fixture to stand-alone music trig or auto trig mode before use (see “Selecting DMX, music trig or auto trig operating modes” on page 15).*

Getting started

Powering on

Once the Mania SCX600/700 is correctly and safely installed, power on at the fixture's power on/off switch. The fixture will start up and reset. The display will show the following messages:

1. **-OK-**
2. Fixture name
3. Software version number
4. **RST**

If the fixture resets successfully, it will display either its DMX address, **SA-M** (stand-alone music trig mode) or **SA-A** (stand-alone auto trig mode).

If any other message is displayed, the fixture has detected an error (see “Error messages” on page 32). If this occurs, switch off, wait a few seconds and switch on again. If the error message appears again, consult your Martin dealer.

Control panel and menus

You can set the Mania SCX600/700's DMX address, modify the fixture's personality and control effects manually using the menus in the control

panel. See also the overviews printed on the fixture and in “*Control menus*” on page 41.

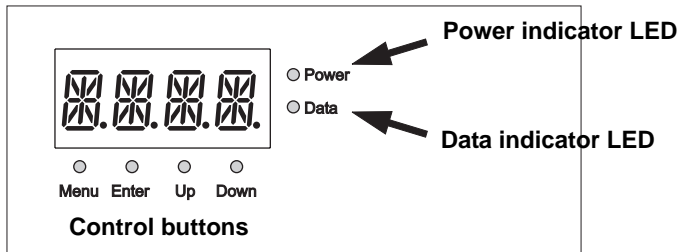

To enter the menus, press the [Menu] button. Use the [Up] and [Down] buttons to scroll within a menu. To select a function or submenu, press the [Enter] button. To exit a function or menu, press the [Menu] button.

Music trig, auto trig and DMX modes

The Mania SCX600/700 has three main operating modes:

Stand-alone music trig mode: In this mode, lighting effects are triggered by music intensity. Multiple fixtures can be synchronized if one master fixture is set to stand-alone music trig mode and the other fixtures are set to DMX mode.

Stand-alone auto trig mode: In this mode, the fixture runs a factory-set dynamic light show that uses all the fixture's effects in a random program. Multiple fixtures can be synchronized if one master fixture is set to stand-alone auto trig mode and the other fixtures are set to DMX mode.

DMX mode: In DMX mode, fixtures receive control instructions via the serial data link. They will respond to control signals from a DMX controller (or from another fixture set as master).

Selecting DMX, music trig or auto trig operating modes

The Mania SCX600/700 is supplied set to DMX mode with its DMX address set to 1. If you intend to operate the fixture without a DMX controller, you need to set it to stand-alone music trig or auto trig mode.

To switch between DMX, auto trig and music trig modes:

1. Apply power to the fixture and wait until the *RST* message disappears from the display. The fixture has now reset.
2. Press the [Menu] button once to enter the control menus.
3. Use the [Up] and [Down] buttons to scroll to *MODE*. Press [Enter] once to enter the operating mode menu.
4. Use the [Up] and [Down] buttons to scroll between:
 - *NORM* (DMX mode)
 - *SA-A* (Stand-alone auto trig mode) and
 - *SA-M* (Stand-alone music trig mode)
5. Press [Enter]. The fixture enters the mode you have selected, and will return to this mode when powered off and on.

Synchronized music trig and auto trig operation

You can set multiple fixtures on a serial data link to respond together to a music trig or auto trig signal from one fixture. This feature allows synchronized operation without a DMX controller. The fixture sending the signal is the 'master' fixture and the fixtures that receive the signal are the 'slave' fixtures.

Important! ***Set only 1 fixture on the link as master: damage can occur if 2 masters, or a master and a DMX controller, are linked.***

Setting up synchronized operation

To set up Mania SCX600/700s for synchronized operation:

1. Ensure that all slave fixtures are in DMX mode.
2. Select one fixture to be the master and set it to stand-alone auto trig or music trig mode (see "*Selecting DMX, music trig or auto trig operating modes*" on page 15)
3. When slave fixtures receive signals from the master, they will automatically begin operating in slave mode. The Data LED on their control panels will light to show that they are receiving control data.

Fixtures return to their DMX/auto trig/music trig settings when powered off and on, so you should only need to set fixtures as masters/slaves once.

DMX controller operation

Setting DMX mode 1 or 2

Two DMX modes are available: DMX mode 1 (normal) and DMX mode 2 (extended). Mode 2 uses four extra DMX channels. Two of these channels allow you to select pre-programmed pan, tilt and effects macros and two channels allow you to set the speed of pan, tilt and effects movement from the DMX controller.

The Mania SCX600/700 is supplied in DMX mode 2.

- The Mania SCX600 uses 7 channels in DMX mode 1, and 11 channels in DMX mode 2.
- The Mania SCX700 uses 6 channels in DMX mode 1, and 10 channels in DMX mode 2.

To toggle between DMX modes 1 and 2:

1. Apply power to the fixture and wait for the fixture to reset.
2. In the control panel, press the [Menu] button. Then use the [Up] and [Down] buttons to scroll to *PSET* (personality setting) and press [Enter].
3. Use the [Up] and [Down] buttons to scroll between *Mod 1* and *Mod 2* and press [Enter] to save your setting.

Setting DMX addresses

If you use a DMX controller, you need to set the DMX address for each fixture on the fixture's control panel. The DMX address, or start channel, is the first channel used to receive instructions from the controller.

For individual control, each fixture must be assigned its own DMX address and control channels. For example, if an SCX600 is set to DMX mode 2 and you give it DMX address 101, it will use channels 101 - 111 inclusive. Channel 112 is available for the next fixture. An SCX700 in DMX mode 2 with address 101 will use channels 101 -110 inclusive. Channel 111 will be available for the next fixture.

Fixtures with the same DMX address will receive the same instructions and behave identically. Two fixtures with the same DMX address can be set up so that one pans as a mirror image of the other. To achieve this, use the settings in the control menu to invert the pan on one fixture (see "*Movement*" on page 21).

The default factory-set DMX address is '1'. To set a fixture's DMX address:

1. Decide on suitable DMX addresses for all the fixtures on the data link. 512 channels are available in one DMX universe.
2. Apply power to the fixture and wait while it resets.
3. Press [Menu] to enter the main menu.
4. Select *Addr* using the [Up] and [Down] buttons. Press [Enter].
5. Select an address using the [Up] and [Down] buttons. Press [Enter].
6. Press [Menu] to return to the main menu.

Fixtures remember their DMX address when they are powered off and on.

DMX control options

See the DMX protocols starting on page 35 for an overview of DMX commands and channels.

In DMX modes 1 and 2, the following functions can be controlled:

Reset: All effects can be reset to their index positions from the controller using channel 1. The reset command must be sent for 5 seconds before it takes effect. When a fixture is reset via DMX, *RST* appears in its display.

Dimming and blackout: Both the SCX600 and SCX700 can be blacked out using the shutter on channel 1. The shutter can also be set to music triggered operation.

The Mania SCX600 can be dimmed from 0% (blackout) up to 100% intensity using channel 2.

The Mania SCX700 can be dimmed from 0% to 100% on channel 1 if *PER* → *INT* is set to *DN* in the control menus.

Note that to douse the Mania SCX700's lamp, a DMX value from 240 to 247 must be sent on channel 1 for at least five seconds. If you douse the lamp, you must wait eight minutes before restriking.

Color wheel position and rotation: The color wheel features 9 full-color filters plus white (no filter). The wheel can be positioned to give full colors, scrolled to give split-color effects, rotated continuously in either direction with variable speed, or set to music triggered operation.

Gobo wheel position and rotation: The gobo wheel features 7 rotating gobos and an open position. Rotating gobos can be selected, shaken at different speeds and set to music triggered operation.

Rotating gobos: Speed and direction of gobo rotation can be controlled. Gobos can also be set to shake, or set to music triggered operation.

On the Mania SCX700, gobo angle can be indexed, i.e. set to a precise angle.

Pan: Pan, with approx. 198° available.

Tilt: Tilt, with approx. 72° available.

In DMX mode 2, the following additional functions can be controlled on four extra channels:

Macros: A range of factory-set macros are available, with macros that control pan/tilt and macros for the other effects on two separate channels. The macros are professionally designed programs that use all the fixture's effects to give complete light shows with minimal user programming required.

Pan/tilt speed and effects speed: The speed at which the fixture's mirror pans and tilts, and the speed at which effects change, can be adjusted on two extra channels. Selecting a speed allows you to adjust fade times when using DMX controllers that do not feature fade time programming (a fade time is the time taken for effects to change from one scene to the next). If you select 'tracking' on these channels, the DMX controller defines fade times.

Unsure about speed and tracking?

As a rule, you should set the fixture to tracking if you are using programmed fade times or macros on your DMX controller. Select an effects speed if you are *not* using programmed fade times or macros on your DMX controller.

However, if you are using fade times on your controller and have set the fixture to tracking, but effects movement is rough and irregular, setting fade times on your controller to zero and selecting an effects speed may give smoother movement.

Effects movement is set to 'tracking' if the fixture is in DMX mode 1 and by default.

DMX signal indicator

When the Mania SCX600/700 receives a valid DMX signal, the Data LED will light to show that the fixture is receiving control data.

Focus adjustment

Never look directly into the light beam while adjusting the focus. The focus adjustment screw is next to the lens aperture. Do not confuse it with the lamp cover release thumbscrew.

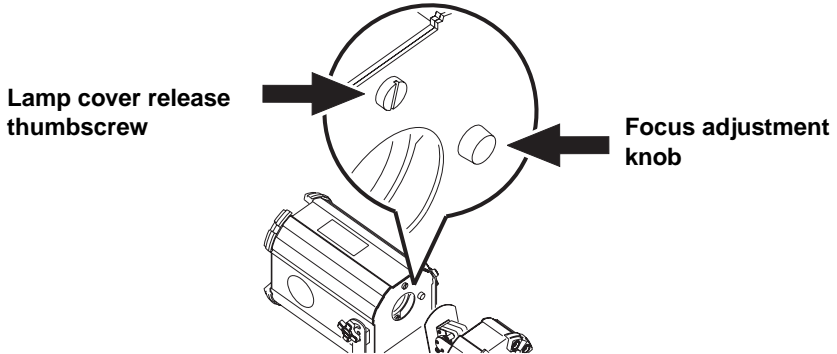

Adjusting music level sensitivity

you can adjust response to a music beat while a fixture is in music trig mode by adjusting music level sensitivity:

1. With the fixture powered on and in music trig mode, play a typical music track at typical volume for your location.
2. Press the [Menu] button once and use the [Up] and [Down] buttons to scroll to *U T I L*. Press [Enter] and scroll to *M L E V*. (music level menu). Press [Enter].
3. The fixture is supplied set to level 7. You can adjust the music sensitivity level using the [Up] and [Down] buttons to select a level from *L E 1* to *L E 15*. Level 1 gives highest sensitivity. Press [Enter] to activate the selected level.
4. Repeat step 3 until you find a level that gives the best response to the music beat.
5. Press [Menu] to save your setting and exit the music level menu. The fixture will return to this setting when you power it off and on.

4. CONTROL PANEL

The following functions of the control panel are described earlier in this manual:

- selecting stand-alone music trig or auto trig operation (see page 15)
- switching between DMX modes 1 and 2 (see page 17)
- setting DMX addresses (see page 17)
- setting music sensitivity level for music trig operation (see page 20).

This chapter describes the other control panel options for setting up fixture behavior (see also “*Control menus*” on page 41 for a complete overview of control panel functions).

Movement

PATI, the pan and tilt invert menu, allows you to invert pan movement (*PINV*), and invert tilt movement (*TINV*). These options can be useful in situations where you want some fixtures to mirror the performance of others with the same DMX address, or when you install fixtures in a different orientation after you have programmed a light show.

Mania SCX700 dimming

In the Mania SCX700, the Personality → Intensity setting *PER*→*INT* lets you use the shutter for dimming. When disabled (the default setting), the low values on channel 1 set the shutter to either fully open or fully closed. When enabled, the shutter can be opened and closed gradually, giving 0-100% continuous dimming.

Information readouts

INFO, the information menu, gives information about hours of fixture and lamp operation, and software version.

Power-on hours

This readout can be used to track maintenance intervals.

There is a resettable counter in this menu. Read the number of hours the fixture has been powered on since the counter was reset in *INFO*→*TIME*→*HRS*→*RSET*. Press [Enter] to display. Press [Up] for 5 seconds to reset the counter to zero.

Read the total number of hours the fixture has been powered on since fabrication in *INFO*→*TIME*→*HRS*→*TOTL*. Press [Enter] to display.

Lamp hours

This readout can be used to monitor lamp life for replacement purposes. There is a resettable lamp hours counter in this menu. Read the number of hours the lamp has been powered on since the counter was reset in *INFO*→*TIME*→*L HR*→*RSET*. Press [Enter] to display. Press [Up] for 5 seconds to reset the counter to zero each time you install a new lamp.

Read the total number of hours of lamp use since fabrication in *INFO*→*TIME*→*L HR*→*TOTL*. Press [Enter] to display.

Start-up/lamp strike counter

INFO→*TIME*→*LST*→*RSET* is a resettable start-up counter. The SCX600 displays the number of times the fixture has been powered on since the counter was last reset. The SCX700 displays the number of times the lamp has been struck since the counter was last reset. Press [Enter] to display. Press [Up] for 5 seconds to reset the counter to zero each time you install a new lamp.

INFO→*TIME*→*LST*→*TOTL* displays the total number of start-ups (SCX600) or lamp strikes (SCX700) since manufacture.

Software version

INFO→*VER* displays the fixture software version number. The software version is also displayed briefly when the fixture is powered on.

Manual control

The manual control menu (*MAN*) provides commands for resetting the fixture (*RST*), as well as striking the lamp (*L ON*), and dousing the lamp (*L OFF*). It also permits you to position and move individual effects.

Effects test

The test sequence (*TSEQ*→*RUN*) runs through all effects to provide a quick check of fixture performance.

Upload mode

The upload mode command (*UTIL*→*UPL*) prepares the fixture for a software upload (see “*Software uploads*” on page 33).

5. SERVICE AND MAINTENANCE

The Mania SCX600/700 requires simple routine maintenance. The maintenance schedule depends heavily on the operating environment; please consult a Martin service technician for recommendations.

Any service procedure not described here should be referred to a qualified technician.

Warning! *Disconnect the fixture from power and allow it to cool for at least 20 minutes before removing any cover.*

Wear safety glasses and gloves and allow the fixture to cool for at least 20 minutes before removing the lamp.

Important! *Excessive dust, grease, and smoke fluid buildup degrades performance and causes overheating and damage to the fixture that is not covered by the warranty. Check and, if necessary, clean fixtures at regular intervals.*

SCX600 lamp

The Mania SCX600 uses a 24 V, 250 W halogen lamp with integral reflector.

Important! *Use only this type of lamp. See “Accessories” on page 47 for details of replacement lamps. Installing any other lamp may damage the fixture.*

Replacing the lamp

1. Disconnect the fixture from power and allow it to cool for at least 20 minutes.

2. Remove the lamp cover release thumbscrew and open the lamp cover on its hinge.

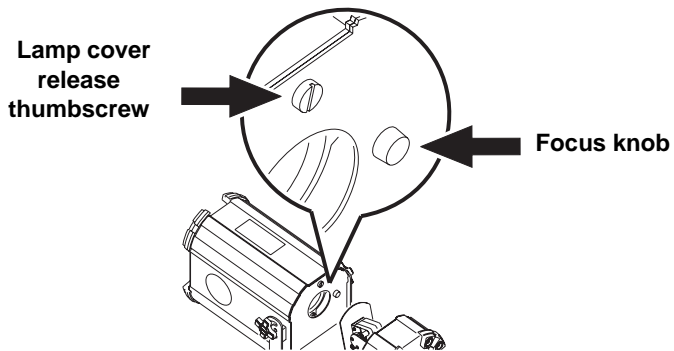

3. Remove the old lamp and socket from the lampholder and, being careful not to strain any wires, gently pull the lamp off its ceramic socket.

4. Hold the new lamp by its base (do not touch any other part of the lamp). Push the lamp pins squarely into the ceramic socket.

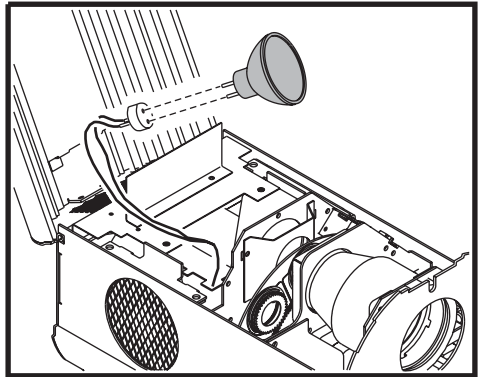

5. If you touched the bulb, the reflector or any optical components, clean them with a clean, lint-free cloth wetted with isopropyl alcohol. Alcohol is extremely inflammable, so take precautions to avoid fire risk.
6. Replace the lamp and socket in the lampholder. Close the cover, checking that no wires are trapped, and replace the thumbscrew.
7. Reset the lamp hours counter (see "*Information readouts*" on page 21).

SCX700 lamp

The Mania SCX700 uses a 150 W discharge lamp. Replace the lamp when it reaches the average life specified by the manufacturer.

Important! Use only this type of lamp. See “Accessories” on page 47 for details of replacement lamps. Installing any other lamp may damage the fixture.

Installing the SCX700 lamp

1. Disconnect the fixture from power and allow it to cool for at least 20 minutes.
2. Remove the lampholder by removing screws A (see illustrations).
3. If replacing an old lamp, remove it from its ceramic socket.
4. Hold the new lamp by its base (do not touch any other part of the lamp). Push the lamp pins squarely into the socket in the lampholder (see illustration).
5. If you touched the bulb, or any optical components, clean them with a clean, lint-free cloth wetted with isopropyl alcohol.
6. Reinstall the lampholder in the fixture, checking that no wires are trapped before screwing on the cover.
7. Reapply power and reset the lamp hours counter (see “Information readouts” on page 21).

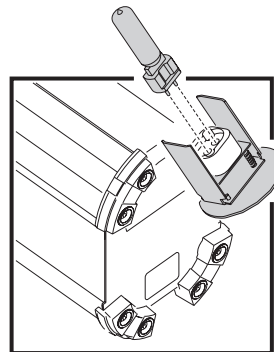
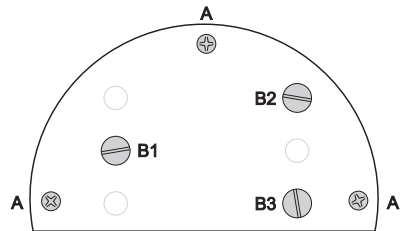
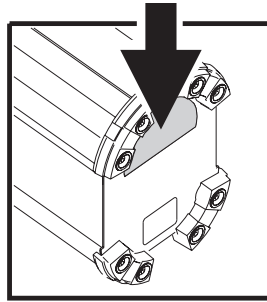

Beam adjustment

1. If the brightest part of the beam is off-center:

- use screw B1 to adjust horizontal lamp alignment
 - use screw B2 and/or B3 to adjust vertical lamp alignment
2. If there is an excessive hot-spot or dark area in the center of the beam, or if light output is low, turn all three screws B1, B2 and B3 by an equal amount in the direction that gives an improvement, until a satisfactory beam is obtained.

Cleaning

Cleaning optical components

Use care when cleaning optical components. The coated surfaces are fragile and even small scratches may be visible in the fixture's light output. Wear cotton gloves to avoid contaminating components with grease from your fingers.

1. Disconnect the fixture from power and allow it to cool for at least 20 minutes.
2. Loosen the lamp cover release thumbscrew and open the lamp cover on its hinge.
3. Blow or vacuum away loose dust. Remove residues from lenses and filters with a soft cloth or cotton swabs wetted with isopropyl alcohol. Regular glass cleaner may also be used, but no residues may remain.
4. Rinse with distilled water. Mixing the water with a small amount of wetting agent such as Kodak Photoflo will help prevent streaking and spotting.
5. Dry with a clean, soft and lint-free cloth or blow dry with compressed air.
6. Replace the lamp cover before reapplying power.

Cleaning the fan and air vents

To maintain adequate cooling, dust must be cleaned from the fan and air vents periodically. Cleaning intervals will depend on the operating environment. The presence of airborne dust, smoke, etc. will make frequent cleaning necessary. Check and, if necessary, clean fixtures regularly.

1. Disconnect the fixture from power and allow to cool for at least 20 minutes.
2. Loosen the lamp cover release thumbscrew and open the lamp cover on its hinge.

3. Remove the two Philips head screws on the fan housing and lift out the fan for access (see illustration).
4. Remove dust and dirt from the fan blades and vent grill using a soft brush or cotton swab and vacuum.
5. Replace the fan, making sure no wires are trapped.
6. Replace the lamp cover before reapplying power.

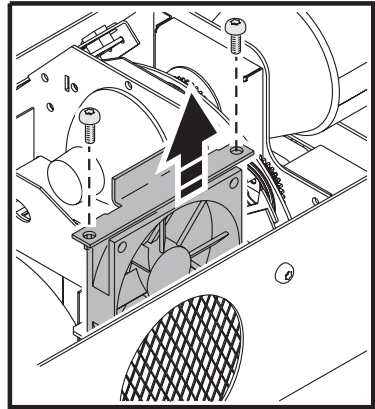

Replacing the main fuse

The Mania SCX600/700 uses a time-delay fuse for protection against current overload. An indication that the fuse may have blown is that when power is applied and the lamp is switched on, no light is produced.

If the fuse blows repeatedly, there is a fault with the unit that requires service by a Martin technician.

Never bypass the fuse or replace it with one of another type or rating.

1. Disconnect the fixture from power and allow to cool for at least 20 minutes.
2. Pry open the fuse holder (located next to the power cable entry) with a flat-head screwdriver and remove the fuse.
3. Replace the fuse with one of the same type. Fuse ratings are listed on serial number labels and under “*Electrical*” on page 46.
4. Replace the fuse holder.
5. If fuses continue to blow, there is probably a fault. Disconnect the fixture from power and data and contact a Martin service technician.

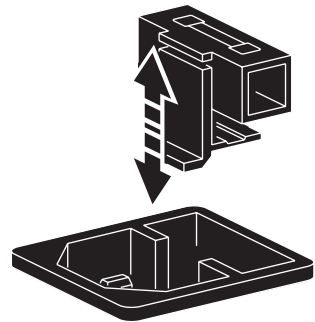

Fuse holder

Replacing a color filter

The color filters fitted to the Mania SCX600/700 are standard interchangeable items.

Wear cotton gloves when changing filters to avoid contaminating components with grease from your fingers.

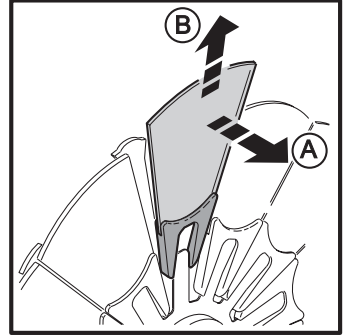
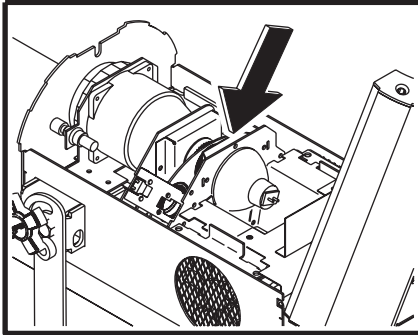

To replace a filter:

1. Disconnect the fixture from power and allow to cool for 20 minutes.
2. Loosen the lamp cover release thumbscrew and open the cover.
3. See illustrations above. The color wheel is in front of the lamp. Pull gently on the filter (A) and slide it up and out of the wheel (B).
4. Slide the new filter down onto its clip.
5. Check that the new filter is held securely and replace the lamp cover before reapplying power.

Rotating gobos

The rotating gobos fitted to the Mania SCX600/700 are standard interchangeable items. A range of replacement gobos is available from your Martin dealer.

When replacing gobos, note the position of the open gobo just to the right of the small magnet.

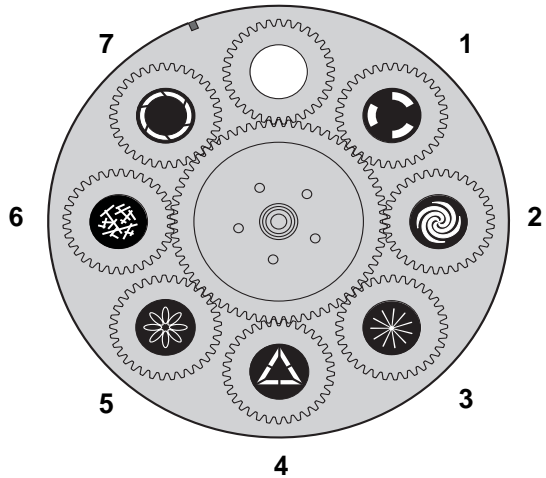

SCX600 gobos (viewed from lens side)

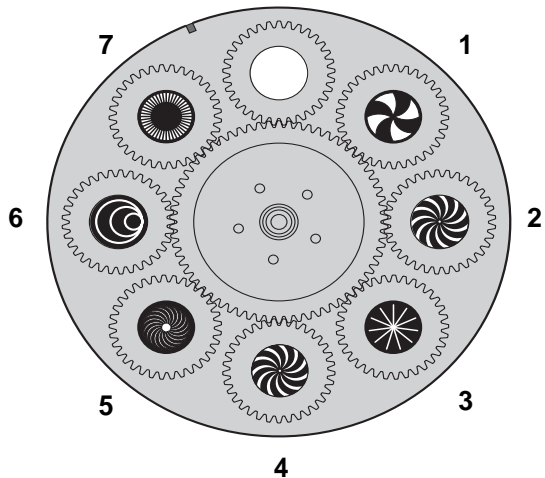

SCX700 gobos (viewed from lens side)

To replace a gobo:

1. Disconnect the fixture from power and allow to cool for at least 20 minutes.
2. Loosen the lamp cover release thumbscrew and open the cover on its hinge.
3. See illustration on right. Pull the gobo gently away from the gobo wheel and slide it up and out of the wheel.
4. Slide the new gobo in and push gently towards the wheel to clip it into place. Check that the gobo is held securely.
5. Replace the lamp cover securely before reapplying power.

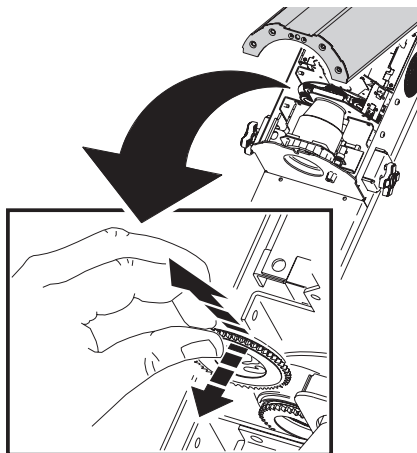

Gobo orientation

Focus is easiest to maintain if all coated gobos in a fixture are installed with their coatings as close as possible to the same plane of focus. The coated gobos in the Mania SCX600/700 are factory-installed with their coated side facing away from the lamp. If there is a risk of heat damage on a custom coated gobo, the first priority is normally to ensure that more reflective sides face towards the lamp. If in doubt, install custom coated gobos with the more reflective side towards the lamp, or consult your Martin dealer or gobo supplier.

More reflective side towards lamp

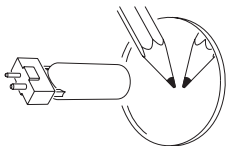

To minimize the risk of gobo overheating and damage, install a coated gobo with the more reflective side facing towards the lamp.

Less reflective side away from lamp

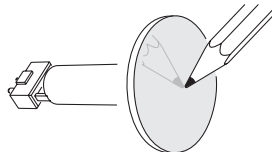

The less reflective side of a coated gobo will absorb less heat if it faces away from the lamp.

To determine which side of a gobo is coated, hold an object up to it. On the uncoated side, there is a space between the object and its reflection, and the edge of the gobo can be seen when looking through the glass.

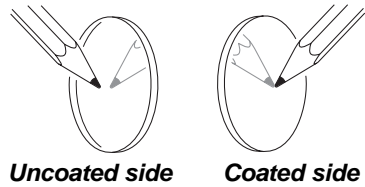

Mirror removal

It is possible to remove the moving mirror without disturbing mirror calibration if you remove the two screws holding the mirror mounting plate and leave the alloy mounting disc on the motor shaft undisturbed (see illustration).

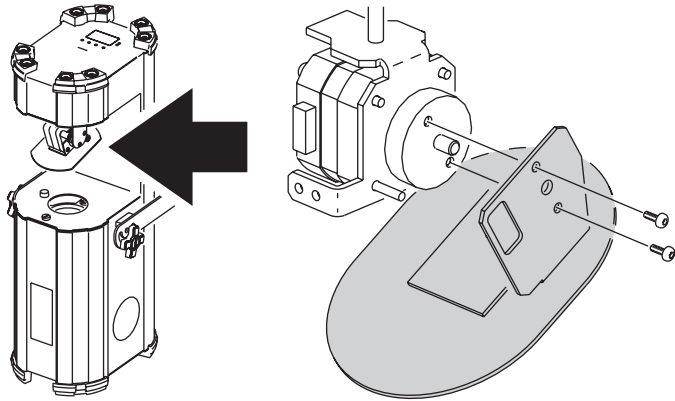

Error messages

In the event of an internal error, the following messages will appear in the digital display:

- **C D E R** – Color wheel timeout.
- **G D E R** – Gobo wheel timeout.

On the Mania SCX700, an additional message will be displayed in the event of an error:

- **R G E R** – Rotating gobo timeout.

If one of the above error messages is displayed, try powering the fixture off and then on again to reset it. If the problem persists, contact your Martin dealer.

On the Mania SCX700, the message *HOT* will be displayed if you douse the lamp via DMX and then try to restrike it within eight minutes.

Software uploads

It is possible to upload new software to the Mania SCX600/700 via the DMX IN connector using, for example, an uploader such as the Martin MP-2 Uploader, or a PC using a Martin DABS interface device and a suitable application such as the Martin Software Uploader. The latest version of the Mania SCX600/700 software and the Martin Software Uploader are available from the Support area of the Martin website at <http://www.martin.com>

To prepare the Mania SCX600/700 to receive new software, select *UTIL*→*UPL* in the control panel, then follow the instructions in the uploader user manual or help files.

If the fixture will not accept a software upload as described above, it can be forced to accept an upload by setting it to hard boot mode. To do this, hold both the [Menu] and the [Enter] button pressed in while powering on the fixture. The data LED will blink when the Mania SCX600/700 is in hard boot mode.

If you have difficulty carrying out uploads, your Martin dealer will be able to give advice or carry out the upload for you.

6. TROUBLESHOOTING

Problem	Probable cause(s)	Remedy
One or more fixtures is completely dead.	No power to fixture.	Check that power is switched on and cables are plugged in.
	Main fuse blown.	Replace fuse.
Fixtures reset correctly but all respond erratically or not at all to controller.	Controller not connected.	Connect controller.
	XLR pin-out of controller does not match pin-out of first fixture on link (i.e. polarity is reversed).	Install a phase-reversing cable between controller and first fixture on link.
Fixtures reset correctly but some respond erratically or not at all to controller.	Bad data link connection.	Inspect connections and cables. Correct poor connections. Repair or replace damaged cables.
	Data link not terminated with 120 Ohm termination plug.	Insert termination plug in output of last fixture on link.
	Incorrect fixture addressing.	Check DMX addresses.
	One of the fixtures is transmitting as a master.	Check all fixture settings.
	One of the fixtures is defective.	Bypass one fixture at a time (unplug both DMX connectors and connect them directly together) until normal operation is regained. Have defective fixture serviced by a Martin technician.
A number appears in display and fixture will not run a stand-alone light show.	Fixture is set to DMX mode and is displaying its DMX address.	Use control panel to change fixture from DMX to stand-alone auto trig or music trig.
An effect fails to reset correctly.	The effect may require mechanical adjustment.	Contact Martin technician for service.
Lamp cuts out intermittently or burns out too quickly.	Fixture is too hot.	Allow fixture to cool.
		Check that there is free airflow around the fixture. Check, and if necessary clean, fan and grills.
Fixture does not respond correctly to music beat in music trig mode.	Music level sensitivity is incorrectly adjusted.	Use control panel to adjust sensitivity until fixture responds satisfactorily.
SCX700: Impossible to restrike lamp after dousing via DMX or powering off.	8-minute restrike protection delay activated or lamp too hot to strike.	Wait 8 minutes before restriking a hot discharge lamp.

7. SCX600 DMX PROTOCOL

Channel	Value	Percent	Function
1			Shutter, strobe effect, music triggered shutter, reset
	0-7	0-2	Shutter closed
	8-15	3-5	Shutter open
	16-95	4-37	Strobe slow → fast
	96-103	38-40	Shutter open
	104-151	41-59	Random strobe slow → fast
	152-159	60-62	Shutter open
	160-199	63-78	Music triggered shutter
	200-207	79-81	Shutter open
	208-247	82-96	Music trigger intensity
	248-251	97-98	Shutter open
	252-255	99-100	Reset (hold for 5 seconds to blackout and reset)
	2	0-255	0-100
3			Color wheel positions, music triggered color chase Continuously scrolling color wheel positions
	0	0	White
	12	4	Color 1 Blue B04
	24	9	Color 2 Red B14
	36	14	Color 3 Yellow B02
	48	18	Color 4 Magenta B12M
	60	23	Color 5 Cyan B05
	72	28	Color 6 Green B08
	84	33	Color 7 Orange B09
	96	37	Color 8 Congo B13
	108	42	Color 9 Pink B16
			Indexed color wheel positions
	120-128	47-50	White
	129-135	51-52	Color 1 Blue B04
	136-142	53-55	Color 2 Red B14
	143-149	56-58	Color 3 Yellow B02
	150-156	59-61	Color 4 Magenta B12M
	157-163	62-64	Color 5 Cyan B05
	164-170	65-66	Color 6 Green B08
	171-177	67-69	Color 7 Orange B09
	178-184	70-72	Color 8 Congo B13
	185-191	73-74	Color 9 Pink B16
			Continuous color wheel rotation
	192-215	75-84	CW fast → slow
	216-239	85-93	CCW slow → fast
			Music triggered color chase
	240-245	94-96	Fast
	246-250	97-98	Medium
	251-255	99-100	Slow

Channel	Value	Percent	Function
4			Gobo selection, gobo shake, music trig gobo chase
			Select gobo (set rotation type on channel 5)
	0-15	0 - 5	Open
	16-31	6-11	Gobo 1: Segments
	32-47	12-18	Gobo 2: Vortex
	48-63	19-24	Gobo 3: Cartwheel
	64-79	25-30	Gobo 4: Deltawindow
	80-95	31-37	Gobo 5: Red Petals
	96-111	38-43	Gobo 6: Straws
	112-127	44-49	Gobo 7: Flying disc
			Gobo shake
	128-143	50-55	Gobo 1, shake fast → slow
	144-159	56-62	Gobo 2, shake fast → slow
	160-175	63-68	Gobo 3, shake fast → slow
	176-191	69-74	Gobo 4, shake fast → slow
	192-207	75-81	Gobo 5, shake fast → slow
	208-223	82-87	Gobo 6, shake fast → slow
224-239	88-93	Gobo 7, shake fast → slow	
		Music triggered gobo chase	
240-245	94-96	Fast	
246-250	97-98	Medium	
251-255	99-100	Slow	
5			Gobo rotation type, music trig gobo rotation speed
			Gobo rotation type (select gobo on channel 4)
	0-7	0 - 2	Stop
	8-77	3-29	Rotation CW slow → fast
	78-147	30-57	Rotation CCW fast→slow
	148-153	58-59	Stop
	154-223	60-87	Rotation CW slow → fast
	224-239	88-93	Rotation shake
			Music triggered rotation
	240-245	94-96	Fast
246-250	97-98	Medium	
251-255	99-100	Slow	
6			Pan
	0 - 255	0 - 100	Left → right (128 = neutral)
7			Tilt
	0 - 255	0 - 100	Down → up (128 = neutral)
8*			Pan & tilt macros (DMX mode 2 only)
	0 - 15	0 - 5	No Macro
	16 - 31	6 - 11	Macro 1
	32 - 47	12 - 18	Macro 2
	48 - 63	19 - 24	Macro 3
	64 - 79	25 - 30	Macro 4
	80 - 95	31 - 37	Macro 5
	96 - 111	38 - 43	Macro 6
	112 - 127	44 - 49	Macro 7
	128 - 143	50 - 55	Macro 8
	144 - 159	56 - 62	Macro 9
	160 - 175	63 - 68	Macro 10
	176 - 191	69 - 74	Macro 11
	192 - 207	75 - 81	Macro 12
208 - 255	82 - 100	Reserved. No function	

Channel	Value	Percent	Function
9*	0 - 15	0 - 5	Effects macros (DMX mode 2 only) No Macro
	16 - 31	6 - 11	Macro 1
	32 - 47	12 - 18	Macro 2
	48 - 63	19 - 24	Macro 3
	64 - 79	25 - 30	Macro 4
	80 - 95	31 - 37	Macro 5
	96 - 111	38 - 43	Macro 6
	112 - 127	44 - 49	Macro 7
	128 - 143	50 - 55	Macro 8
	144 - 159	56 - 62	Macro 9
	160 - 175	63 - 68	Macro 10
	176 - 191	69 - 74	Macro 11
	192 - 207	75 - 81	Macro 12
208 - 255	82 - 100	Reserved. No function	
10*	0-7	0-2	Pan & tilt speed (DMX mode 2 only) Tracking (default)
	8-240	3-94	Fast → slow
	241-245	95-96	Blackout during color and gobo changes
	246-250	97-98	Blackout during pan and tilt changes
	251-255	99-100	Blackout during color, gobo, pan and tilt changes
11*	0-7	0-2	Effects speed (DMX mode 2 only) Tracking (default)
	8-255	3-100	Fast → slow

* Channels 8 - 11 are available in DMX mode 2 only. In DMX mode 1, pan & tilt speed and effects speed are set to tracking.

8. SCX700 DMX PROTOCOL

Channel	Value	Percent	Function
1	0-18 19-38	0-7 7-14	Shutter, dimmer, strobe effect, reset <i>With dimming disabled in PER → INT (default)</i> Shutter closed Shutter open
	0-38	0-14	<i>With dimming enabled in PER → INT</i> Continuous dimming, 0% - 100% intensity
2	39-95 96-103 104-151 152-159 160-199 200-207 208-219 220-239 240-247	15-37 38-40 41-59 60-62 63-78 79-81 82-85 86-93 94-96	Strobe slow → fast Shutter open Random strobe slow → fast Shutter open Music triggered shutter Shutter open Lamp on Shutter open Lamp off (must be held for 5 seconds. 8 min. delay before lamp can be restruck)
	248-251 252-255	97-98 99-100	Shutter open Reset (must be held for 5 seconds to blackout and reset)
			Color wheel positions and rotation, music trig color chase
			Continuously scrolling color wheel positions
	0	0	White
	12	4	Color 1 Blue B04
	24	9	Color 2 Red B14
	36	14	Color 3 Yellow B02
	48	18	Color 4 Magenta B12M
	60	23	Color 5 Cyan B05
	72	28	Color 6 Green B08
	84	33	Color 7 Orange B09
	96	37	Color 8 Congo B13
	108	42	Color 9 Pink B16
			Indexed color wheel positions
120-128	47-50	White	
129-135	51-52	Color 1 Blue B04	
136-142	53-55	Color 2 Red B14	
143-149	56-58	Color 3 Yellow B02	
150-156	59-61	Color 4 Magenta B12M	
157-163	62-64	Color 5 Cyan B05	
164-170	65-66	Color 6 Green B08	
171-177	67-69	Color 7 Orange B09	
178-184	70-72	Color 8 Congo B13	
185-191	73-74	Color 9 Pink B16	
		Continuous color wheel rotation	
192-215	75-84	CW fast → slow	
216-239	85-93	CCW slow → fast	
		Music triggered color chase	
240-245	94-96	Fast	
246-250	97-98	Medium	
251-255	99-100	Slow	

Channel	Value	Percent	Function
3			Gobo selection, gobo shake, music trig gobo chase
			Gobo indexing: select gobo (set indexing angle on channel 4)
	0-7	0 - 2	Open
	8-15	3-5	Gobo 1: Parasol twist
	16-23	6-8	Gobo 2: Plaid dream, cyan B20,
	24-31	9-11	Gobo 3: Cartwheel
	32-39	12-14	Gobo 4: Plaid dream, think pink B12M
	40-47	15-18	Gobo 5: Spiral galaxy
	48-55	19-21	Gobo 6: Moons, blue 04
	56-63	22-24	Gobo 7: Radial burst
			Gobo rotation: select gobo (set movement on channel 4)
	64-71	25-27	Gobo 1: Parasol twist
	72-79	28-30	Gobo 2: Plaid dream, cyan B20,
	80-87	31-33	Gobo 3: Cartwheel
	88-95	34-37	Gobo 4: Plaid dream, think pink B12M
	96-103	38-40	Gobo 5: Spiral galaxy
	104-111	41-43	Gobo 6: Moons, blue 04
	112-127	44-49	Gobo 7: Radial burst
			Gobo shake
	128-143	50-55	Gobo 1, shake fast → slow
144-159	56-62	Gobo 2, shake fast → slow	
160-175	63-68	Gobo 3, shake fast → slow	
176-191	69-74	Gobo 4, shake fast → slow	
192-207	75-81	Gobo 5, shake fast → slow	
208-223	82-87	Gobo 6, shake fast → slow	
224-239	88-93	Gobo 7, shake fast → slow	
		Music triggered gobo chase	
240-245	94-96	Fast	
246-250	97-98	Med	
251-255	99-100	Slow	
4			Gobo indexing angle, gobo rotation movement, music trig gobo rotation
			Gobo indexing angle (select gobo on channel 3)
	0-255	0-100	Indexing 0-395°
			Gobo rotation: set movement (select gobo on channel 3)
	0-7	0 - 2	Stop
	8-77	3-29	Rotation CW slow → fast
	78-147	30-57	Rotation CCW fast→slow
	148-153	58-59	stop
	154-223	60-87	Rotation CW slow → fast
	224-239	88-93	Rotation shake
		Music triggered rotation	
240-245	94-96	Fast	
246-250	97-98	Med	
251-255	99-100	Slow	
5	0 - 255	0 - 100	Pan Left → right (128 = neutral)
	6	0 - 255	0 - 100

Channel	Value	Percent	Function
7*	0 - 15	0 - 5	Pan & tilt macros (DMX mode 2 only) No Macro
	16 - 31	6 - 11	Macro 1
	32 - 47	12 - 18	Macro 2
	48 - 63	19 - 24	Macro 3
	64 - 79	25 - 30	Macro 4
	80 - 95	31 - 37	Macro 5
	96 - 111	38 - 43	Macro 6
	112 - 127	44 - 49	Macro 7
	128 - 143	50 - 55	Macro 8
	144 - 159	56 - 62	Macro 9
	160 - 175	63 - 68	Macro 10
	176 - 191	69 - 74	Macro 11
	192 - 207	75 - 81	Macro 12
208 - 255	82 - 100	Reserved. No function	
8*	0 - 15	0 - 5	Effects macros (DMX mode 2 only) No Macro
	16 - 31	6 - 11	Macro 1
	32 - 47	12 - 18	Macro 2
	48 - 63	19 - 24	Macro 3
	64 - 79	25 - 30	Macro 4
	80 - 95	31 - 37	Macro 5
	96 - 111	38 - 43	Macro 6
	112 - 127	44 - 49	Macro 7
	128 - 143	50 - 55	Macro 8
	144 - 159	56 - 62	Macro 9
	160 - 175	63 - 68	Macro 10
	176 - 191	69 - 74	Macro 11
	192 - 207	75 - 81	Macro 12
208 - 255	82 - 100	Reserved. No function	
9*	0-7	0-2	Pan & tilt speed (Mode 2 only) Tracking (default)
	8-240	3-94	Fast → slow
	241-245	95-96	Blackout during color and gobo changes
	246-250	97-98	Blackout during pan and tilt changes
	251-255	99-100	Blackout during color, gobo, pan and tilt changes
10*	0-7	0-2	Effect speed (Mode 2 only) Tracking (default)
	8-255	3-100	Fast → slow

* Channels 7- 10 are available in DMX mode 2 only. In DMX mode 1, pan & tilt speed and effects speed are set to 'tracking'.

9. CONTROL MENUS

Factory default settings are shown in bold type.

Menu	Item	Options	Notes (default settings in bold print)
<i>Addr</i>		<i>1-5 12</i>	DMX address (default address = 1)
<i>PATI</i>		<i>PINV</i>	Pan invert
		<i>TINV</i>	Tilt invert
<i>PSET</i>		<i>MOd1</i>	DMX mode 1 (normal)
		<i>MOd2</i>	DMX mode 2 (extended)
<i>MODE</i>	<i>NORM</i>		DMX-controlled operation / slave fixture
	<i>SA-R</i>		Stand-alone auto trig operation / auto trig master fixture
	<i>SA-M</i>		Stand-alone music trig operation / music trig master fixture
<i>PER</i>	<i>INT</i>	<i>OFF</i>	Dimming disabled (SCX700 only)
		<i>ON</i>	Dimming enabled (SCX700 only)
<i>INFO</i>	<i>TIME</i>	<i>HRS</i>	<i>TOTL</i> = total hours of operation since manufacture. <i>RESET</i> = resettable counter. Press [Enter] to display hours of operation since counter reset. To reset to zero, press [Up] for 5 seconds.
		<i>LHR</i>	<i>TOTL</i> = total hours of lamp operation. <i>RESET</i> = resettable counter. Press [Enter] to display hours of lamp operation since counter reset. To reset to zero, press [Up] for 5 seconds.
		<i>LST</i>	SCX600: <i>TOTL</i> = total number of startups (power-ons). SCX700: <i>TOTL</i> = total number of lamp strikes. <i>RESET</i> = resettable counter. Press [Enter] to display number of startups/lamp strikes since counter reset. To reset to zero, press [Up] for 5 seconds.
	<i>VER</i>	<i>x.x.x</i>	CPU software version number

Table 2: Control menu

MAN		RST	Reset fixture	
		L ON	Lamp on	
		L OFF	Lamp off	
	SHUT		OPEN	Open shutter
			CLOS	Close shutter
			STRF	Shutter strobe fast
			STRM	Shutter strobe medium
			STRS	Shutter strobe slow
	DIM	0-255	Dimmer	
	COL		OPEN	Color wheel in open position
			C 1 → C 9	Color wheel positions 1 → 9
			CW F	Clockwise rotation - fast
			CCWF	Counter-clockwise rotation - fast
			CW M	Clockwise rotation - medium
			CCWM	Counter-clockwise rotation - medium
			CW S	Clockwise rotation - slow
		CCWS	Counter-clockwise rotation - slow	
	GOBO	0 → 7 G 7 RS → G 1 RS	Gobo selection 0 → 7 Gobo wheel shake gobo 7 → 1	
	I/S	0-255	Gobo rotation speed slow → fast	
PAN	0-255	Pan left → right		
TILT	0-255	Tilt up → down		
TSEQ		RUN	Run a general test of all effects	
UTIL (Press [Enter] for 3 secs. to access)	UPLD	SURE	Manually set fixture to software update mode	
	MLEV	LE 1 → LE 16	Music sensitivity level (1 = most sensitive, 7 = default)	

Table 2: Control menu

10. CIRCUIT BOARD LAYOUTS

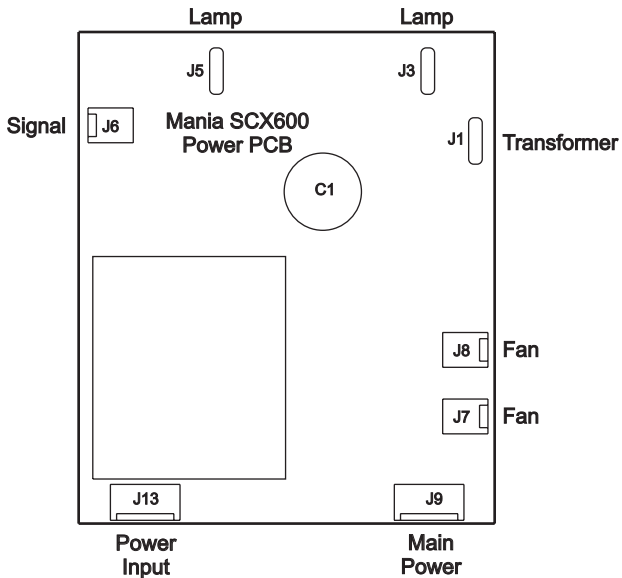
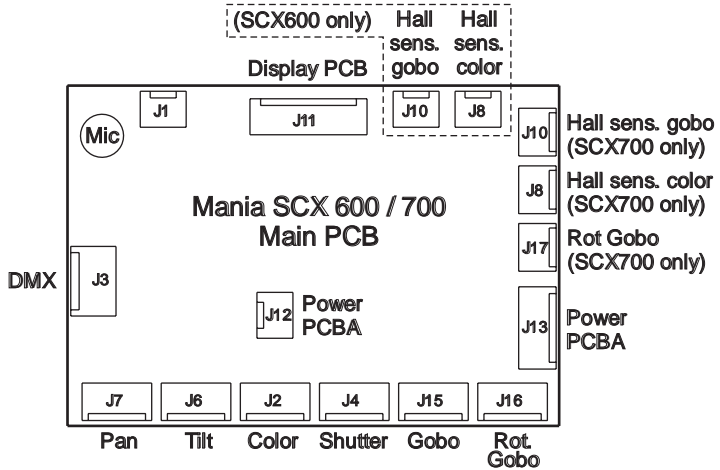

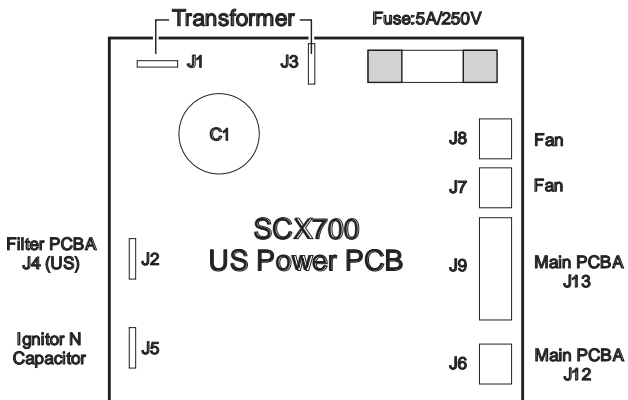
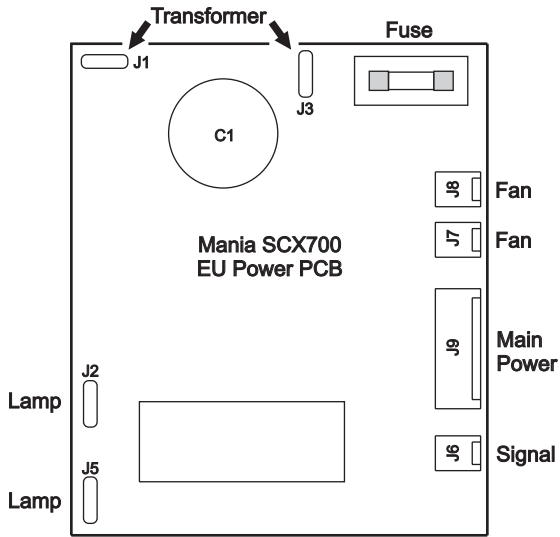

MANIA SCX600/700 SPECIFICATIONS

Physical

Size (L x W x H)	525 x 172 x 203 mm (20.7 x 6.8 x 8.0 in.)
Height (including bracket)	408 mm (16.1 in.)
Mania SCX600 weight (including bracket)	12.3 kg (27.1 lbs)
Mania SCX700 weight (including bracket)	13.0 kg (28.7 lbs)

Installation

Minimum distance to combustible materials	0.1 m (4 in.)
Minimum distance to illuminated surfaces	1 m (3.3 ft.)
Minimum clearance around fan and air vents	0.1 m (4 in.)

Construction

Housing	Steel and aluminum
-------------------	--------------------

Source

Mania SCX600 lamp	24 V, 250 W halogen with integral reflector
Mania SCX600 lamp socket	G5.3
Mania SCX700 lamp	150 W discharge
Mania SCX700 lamp socket	G12

Control and programming

DMX control	USITT DMX-512 (1990) DMX protocol
Mania SCX600 DMX channels	7 (mode 1) or 11 (mode 2)
Mania SCX700 DMX channels	6 (mode 1) or 10 (mode 2)
DMX connections I/O	3-pin locking XLR, pin 1 shield, pin 2 cold (-), pin 3 hot (+)
Stand-alone music trig (single fixture and synchronized master-slave)	
Stand-alone auto trig (single fixture and synchronized master-slave)	
Individual effects can be set to music trig via DMX	

Dynamic effects

Color wheel: 9 interchangeable dichroic color filters plus open position.	
Rotating gobo wheel: 7 interchangeable rotating gobos (SCX600: 5 metal, 2 coated glass, SCX700: 4 metal, 3 coated glass)	
Gobo angle indexing (Mania SCX700 only)	
Gobo rotation and shake effects.	
Mechanical shutter with variable frequency strobe effects.	
Moving mirror: 198° pan and 72° tilt.	
Full range continuous dimming	

Optics

Manual focus	2m (6.6 ft.) - 20m (65.6 ft.)
Beam angle	17.6°

Electrical

Mania SCX600 all models

Input. 3-prong IEC male socket
AC power. switch-selectable, 110-120 V, 60 Hz / 220-240 V, 50 Hz
Main fuse. 3.15 AT

Typical power and current*

@ 110 V, 60 Hz 241 W, 2.2 A, PF 0.993
@ 120 V, 60 Hz 278 W, 2.3 A, PF 0.993
@ 220 V, 50 Hz 241 W, 1.1 A, PF 0.995
@ 230 V, 50 Hz 260 W, 1.2 A, PF 0.995
@ 240 V, 50 Hz 278 W, 1.2 A, PF 0.994

Mania SCX700 EU model

Input. 3-prong IEC male socket
AC power. switch-selectable, 230 V / 240 V, 50 Hz
Main fuse. 2 AT

Typical power and current*

@ 220 V, 50 Hz 193 W, 1.0 A, PF 0.955
@ 230 V, 50 Hz 208 W, 1.0 A, PF 0.942
@ 240 V, 50 Hz 214 W, 1.0 A, PF 0.945

Mania SCX700 US model

Input. 3-prong IEC male socket
AC power. 115-120 V, 60 Hz
Main fuse. 3.15 AT

Typical power and current*

@ 110 V, 60 Hz 194 W, 1.9 A, PF 0.950
@ 120 V, 60 Hz 215 W, 2.0 A, PF 0.905

* V = volts, Hz = hertz, W = watts, A = amps, PF = power factor

Allow for a deviation of +/- 10% from typical figures listed above.

Measurements made at nominal voltage. Local supply voltages can vary by +/-10%.

Thermal

Maximum ambient temperature (T_a) 40° C (104° F)
Maximum surface temperature 80° C (176° F)

Approvals



EU safety. EN 60598-1, EN 60598-2-17
EU EMC. EN 55015, EN 61547, EN 61000-3-2, EN 61000-3-3
EU EMC for SCX700, in addition to standards listed above . . . EN 55022, EN 55024
US safety. UL 1573
Canadian safety. CSA C22.2 NO 166

Included items – EU models

3 meter (9.8 ft) EU power cable, 3 x 1.0 mm ² , Schuko male connector	
3 meter (9.8 ft) EU power cable, 3 x 1.0 mm ² , no male connector	
5 meter (16.4 ft.) RS-485 XLR cable for data link	P/N 11820008
L type 5mm Allen key	P/N 50520615
User manual	P/N 35000169
Adjustable U-bracket	
Mania SCX600: long-life 250 W halogen lamp (installed)	
Mania SCX600: 3.15 AT 5x20 mm main fuse (installed)	P/N 05020043
Mania SCX700: long-life 150 W discharge lamp	
Mania SCX700: 2 AT 5x20 mm main fuse (installed)	P/N 05020009

Included items – US models

2 meter (6.5 ft.) US AC power cable, 18AWG, US male connector (UL approved)	
5 meter (16.4 ft.) RS-485 XLR cable for data link	P/N 11820008
L type 5mm Allen key	P/N 50520615
3.15 AT main fuse (installed)	P/N 05020043
User manual	P/N 35000169
Adjustable U-bracket	
Mania SCX600: long-life 250 W halogen lamp (installed)	
Mania SCX600: 3.15 AT 5x20 mm main fuse (installed)	P/N 05020043
Mania SCX700: long-life 150 W discharge lamp	
Mania SCX700: 3.15 AT 5x20 mm main fuse (installed)	P/N 05020043

Accessories

Philips ELC 10H 24 V, 250 W halogen lamp (SCX600)	P/N 97000109
Philips MasterColor CDM-SA/T 150 W discharge lamp (SCX700)	P/N 97010111
Philips MSD 150/2 150 W discharge lamp (SCX700)	P/N 97010117
DMX termination plug (end of link), XLR male	P/N 91613017
DMX termination plug, (start of link, master/slave), XLR female	P/N 91613018
G-clamp	P/N 91602003
Half-coupler clamp	P/N 91602005
5-pin male to 3-pin female XLR adaptor cable	P/N 11820005
5 meter (16.4 ft.) RS-485 XLR cable for data link	P/N 11820008
Mania SCX600 (all models) main fuse, 3.15 AT	P/N 05020043
Mania SCX700 (EU models) main fuse, 2 AT	P/N 05020009
Mania SCX700 (US models) main fuse, 3.15 AT	P/N 05020043

Ordering information

Mania SCX600 EU model, 220-240 V, 50 Hz	P/N 90430082
Mania SCX600 US model, 110-120 V, 60 Hz	P/N 90430083
Mania SCX 700 EU model, 220-240 V, 50 Hz.	P/N 90430084
Mania SCX 700 US model, 110-120 V, 60 Hz.	P/N 90430085



Disposing of this product

Martin® products are supplied in compliance with Directive 2002/96/EC of the European Parliament and of the Council of the European Union on WEEE (Waste Electrical and Electronic Equipment), as amended by Directive 2003/108/EC, where applicable.

Help preserve the environment! Ensure that this product is recycled at the end of its life. Your supplier can give details of local arrangements for the disposal of Martin products.

Martin

www.martin.com • Olof Palmes Allé 18 • 8200 Aarhus N • Denmark
Tel: +45 8740 0000 • Fax +45 8740 0010