



User manual

CN12

CM12

CM15

CM18



Please read this manual carefully before attempting to install the product

Every effort has been taken to ensure that these instructions are correct. Mach Speakers A/S does not accept any liability for loss or damage caused or alleged to be caused directly or indirectly by these instructions. The contents of the instructions may be subject to change without notice. Mach Speakers A/S makes no warranty of any kind with regard to these instructions.

Copyright 2004 Mach Speakers A/S, Denmark.

All rights reserved. No part of these instructions may be reproduced, in any form or by any means, without permission in writing from Mach Speakers A/S, Denmark.

Mach Speakers A/S • Perspektivvej 2 • 9900 Frederikshavn • Denmark
Tel: +45 72 15 08 52 • Fax: +45 98 43 14 15 • e-mail: Mach-Service@martin.dk

Table of contents

Introduction	3
The C-range	4
Contents of the box	4
Description of the C-range speakers	6
Installation	7
Mounting points on the cabinet	7
Spider bracket	8
How to install your C-range speaker on the optional Multibracket	9
How to install your C-range speaker with the U-bracket	11
How to mount speaker with eyebolts	12
Rotatable horn	13
Horn protection	13
Connection	14
How to connect speaker cable to barrier strip terminals	14
How to attach safety wire	14
Connecting to amplifier	15
Cables	15
Simple connection CN12	15
Parallel system CN12	16
System configuration	17
Switching between Passive and Active mode	18
Parallel system in passive mode CM12, CM15 and CM18	19
Configuring your Mach CM system for active mode operation	20
Painting the speaker	23
Maintenance of speakers	24
How to remove grille	24
How to change drivers/woofers	24
How to remove spider bracket	24
How to remove terminal module	24
How to change crossover	24
Technical information	25
Specsheet CN12	25
Specsheet CM12	26
Specsheet CM15	27
Specsheet CM18	28
Warranty	29
Declaration of conformity	29
Ordering spare parts	30
C- range overview	31
CI range overview	33

Introduction

Thank you for purchasing a product from Mach Speakers A/S. Every effort has been made to ensure that our products meet your requirements and we sincerely hope that we will live up to your expectations.

To get the most out of your Mach speakers and ensure an easy and trouble-free installation please read the manual carefully and follow the instructions.

If you have any additional questions or comments please do not hesitate to contact our headquarters in Denmark at the following address:

Mach Speakers A/S
Perspektivvej 2
DK-9900 Frederikshavn
Denmark
Tel: +45 72150852

<http://www.mach.dk>

Or send an e-mail to: machservice&support@martin.dk

The C-range

The C-range has been designed specifically for professional installations as a high quality, ultra-flexible solution with either a U-bracket or eyebolts included in one convenient package.

The cabinets have been shaped to achieve both an appealing and attractive appearance and very easy mounting and positioning.

Special care has been taken to ensure that a minimum of tools (and time) is required for mounting and adjusting the speakers.

The C-range has been designed for general purpose sound installations such as restaurants, night clubs, houses of worship, theatres, auditoriums etc. To cover all individual requirements in each application the range consists of many different models from compact two-way full-range near-field boxes to full-scale night club dance floor subwoofer systems.

All C-range products are made using only the very best materials and constructed for heavy-duty use in professional environments.

All top boxes are constructed using specially designed extruded aluminum profiles to give market-leading strength and durability. The profiles also enable the use of the innovative fully adjustable spider bracket that makes the installation of the new C-range top boxes more flexible than any other comparable product on the market.

To further aid installation, all boxes have at least 14 fixed mounting points in addition to the four adjustable ones and the four on the spider bracket.

Other ground-breaking features on the new C-range top boxes are recessed terminals with both NL-4 connectors and barrier strip terminals for mounting flush against a wall and full enclosure coating in Mach Safecoat for maximum scratch resistance.

Contents of the box

The Mach C-range is supplied as a complete system and your **CN12** and **CM12** package should contain the following items:

- 1 Speaker
- 1 Spider bracket (mounted on speaker cabinet)
- 1 U-bracket
- 3 Eyebolts
- 1 Manual
- 1 Speakon connector

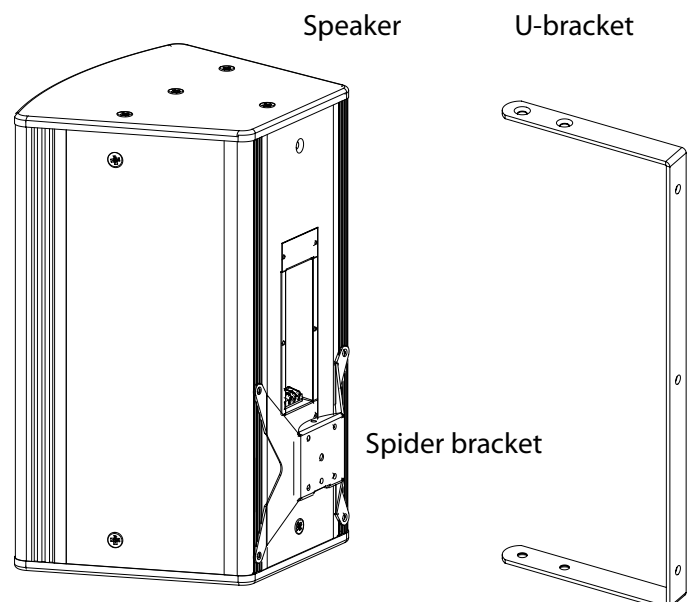
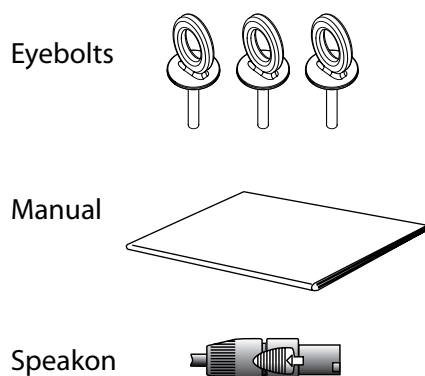

Your **CM15** package should contain the following items:

- 1 Speaker
- 1 Spider bracket (mounted on speaker cabinet)
- 3 Eyebolts
- 1 Manual
- 1 Speakon connector

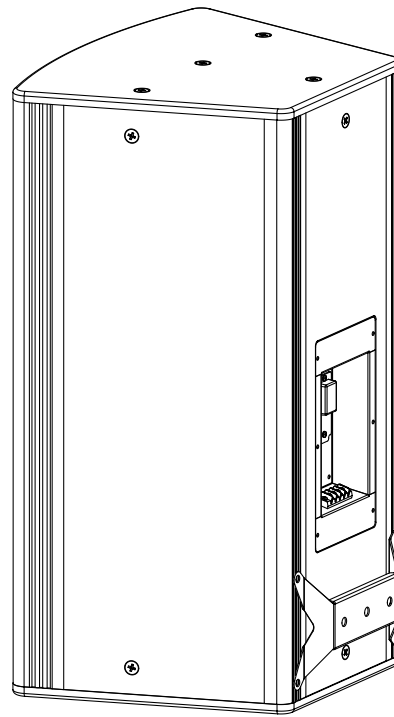
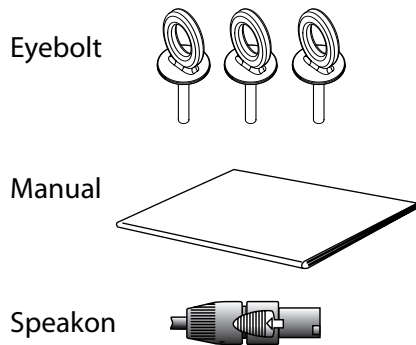

Spider bracket

Your **CM18** package should contain the following items:

- 1 Speaker
- 1 Spider bracket (mounted on speaker cabinet)
- 3 Eyebolts
- 1 Manual
- 1 Speakon connector

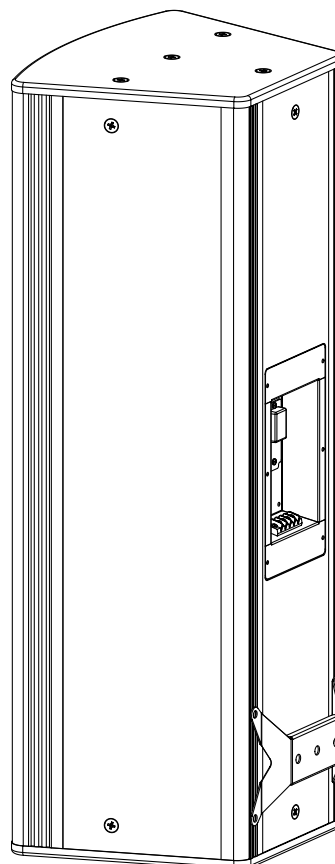
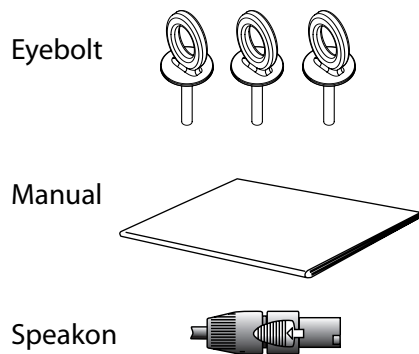

Spider bracket

Description of the C-range speakers

The range can be divided into 3 different groups of products:

- CN
 - o Near-field top boxes and full-range speakers for medium SPL application where ultimate sound quality is required at low-to-medium SPL with low-to-medium projection and with wide dispersion.
- CM
 - o Medium-throw top boxes and full-range speakers for high SPL applications where ultimate sound quality is required at medium-to-high SPL with medium projection and with more focused dispersion.
- CW
 - o Dedicated installation subwoofer to complement CN and CM top boxes.

To illustrate the difference between a CN box and a CM box consider two typical installations:

- A small club with a large bar and entertainment area plus a small dance floor with low ceiling.
- A medium-to-large dance club with a large dance floor and surrounding seating areas, high ceiling and live DJ.

In the small club the ideal solution has good, tightly controlled distribution, high quality warm sound at low-to-medium SPL, small cabinet size but still an output high enough for an intense dance experience. The system will typically run at varied output levels between 30 and 80 % of maximum output.

In the larger dance club high SPL, clean, solid sound with minimum distortion and extreme endurance is an absolute must. Good sound quality at low to medium SPL is less of an issue as the system will always run at close to 100 % output.

In many venues the ideal solution will actually be a mixture of CN and CM boxes for different sections of the venue thus the new C-range enables the building of a complete solution customized for the specific requirements of most customers.

Installation

Your new Mach C-range speaker is one of the most versatile products on the market and every possible effort has been made to make it quick and easy to install your product. The many different installation options available will be described below.

Mounting points on the cabinet

The mounting points on the CN and CM cabinets are shown in the illustration below.

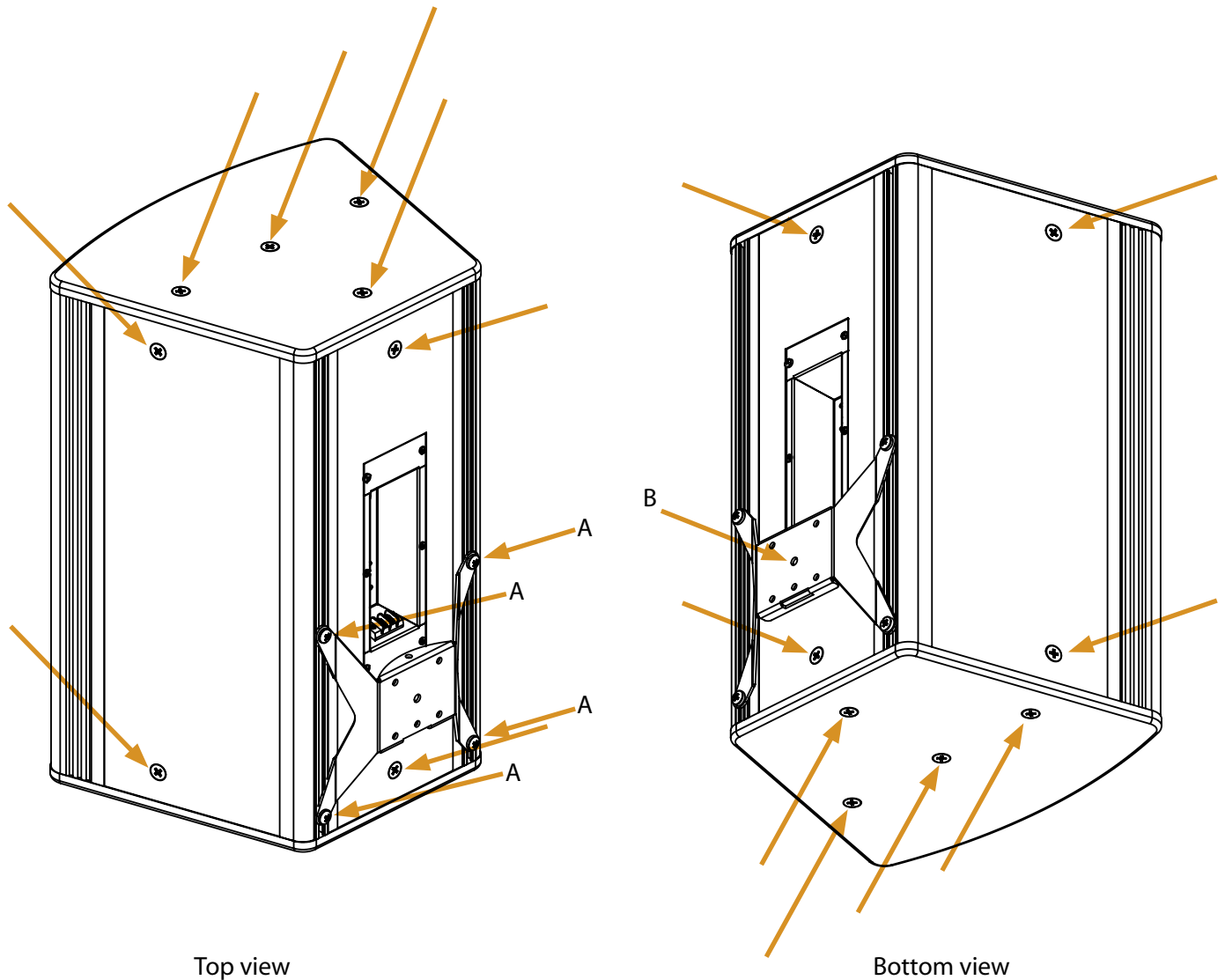

In total the cabinet has 18 mounting points four of which are vertically adjustable (A). In addition, the spider bracket has a mounting point that can be used for an eyebolt (B).

Spider bracket

All CN12 and CM12 speakers are supplied with the revolutionary spider bracket shown below.

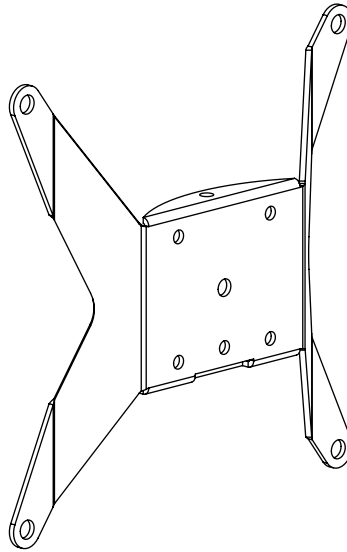

The bracket can be mounted vertically and horizontally depending on the direction the speaker should be flown and enables easy mounting with a minimum of time and effort.

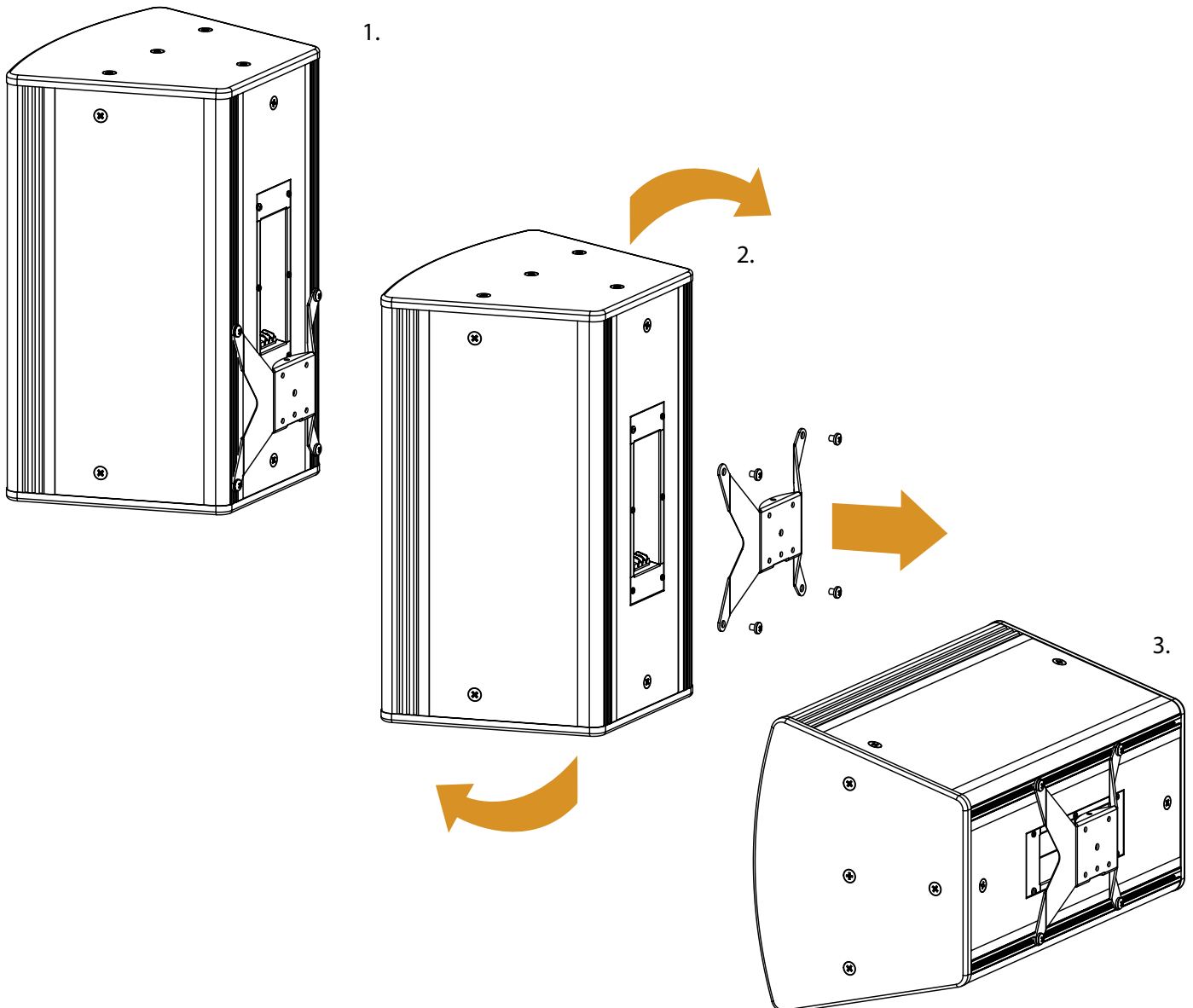

How to install your C-range speaker on the optional Multibracket

The C-range is available with an optional Multibracket that represents the optimum solution for many types of wall and ceiling installations.

Adjusting the angle

Loosen the vertical adjustment locking bolt, remove the locking pin and adjust the bracket to the required vertical position. Replace the locking pin and tighten the locking bolt. Adjust the bracket horizontally and tighten the locking bolt underneath the arm.

Note! The Multibracket may not be used with CM15 and CM18

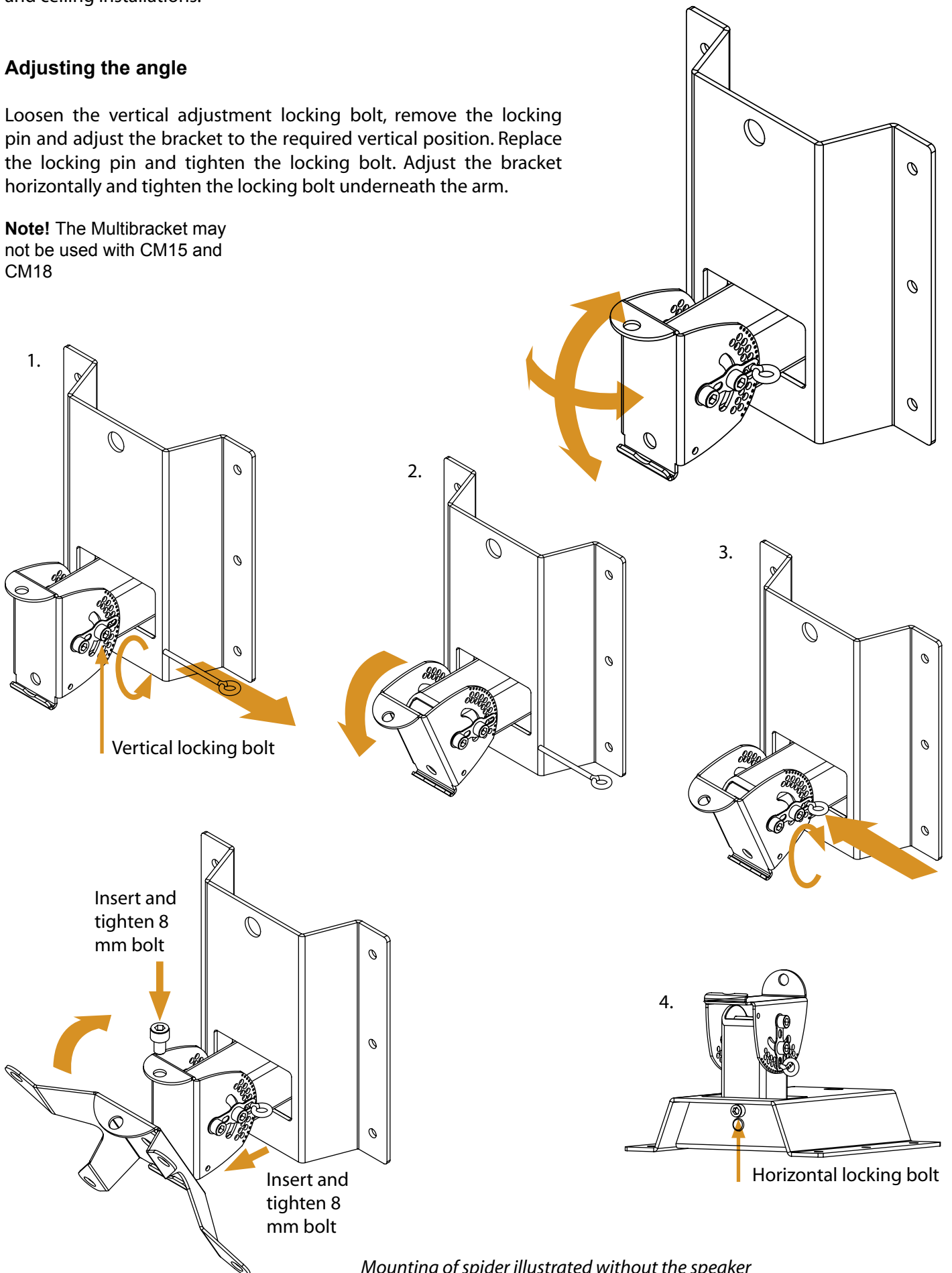

Mounting of spider illustrated without the speaker

To mount a CN or CM cabinet on a wall please use the following procedure

1. Find the correct position on the wall and mark where the base of the bracket should be positioned
2. Take the bracket and hold the base flat to the wall at the marked position
3. Mark each hole with a marking tool or a pencil
4. Remove the bracket
5. Drill a hole of the diameter and depth appropriate for the rawplug you plan to insert
6. Insert a rawplug into each hole
7. Position the bracket so that the mounting holes align with the holes in the wall
8. Screw the bracket lightly to the wall in the corners
9. Align the bracket horizontally
10. Insert the last two screws and tighten all 6 screws appropriately. The bracket has been designed to carry a speaker no larger than the CM 12 weighing no more than 40 kg (88 lbs)

Note! Proper backing or wall structure is required

The Multibracket is extremely versatile as illustrated and enables very flexible adjustment of speaker orientation.

Wall mounting

Horizontal



Vertical



Ceiling mounting

Horizontal



Vertical



Illustrated with CN8

How to install your C-range speaker with the U-bracket

All the smaller models in the C-range are supplied with a U-bracket as standard. For many installation purposes this bracket will be the optimum solution as it is very versatile and easy to use. Illustrated below are a number of ways to use the U-Bracket.

Note! Illustration shows U-bracket for CN12 and CM12

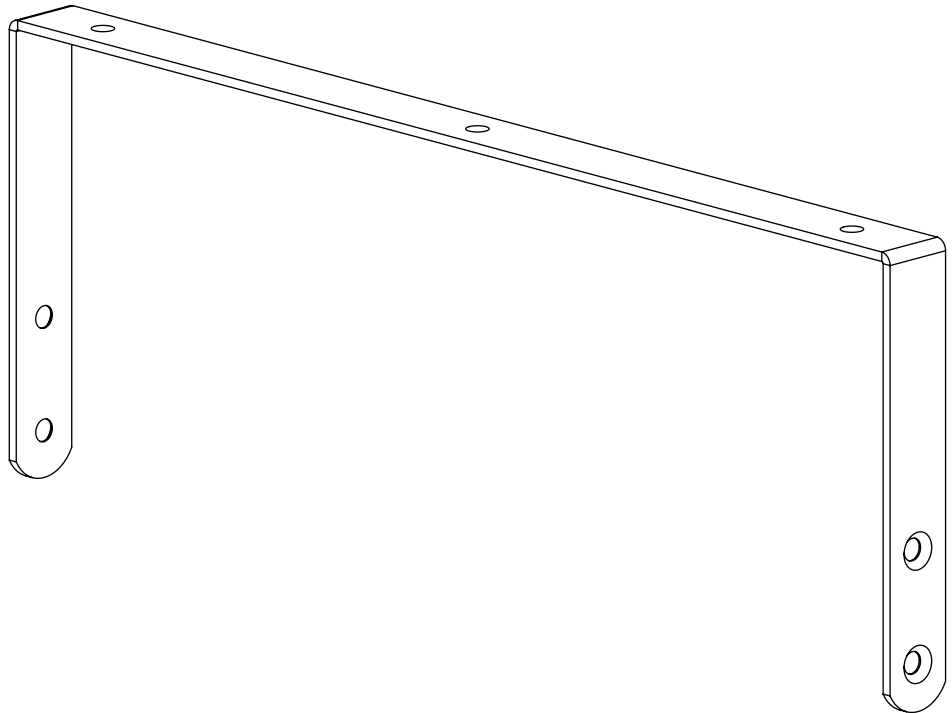

Wall mounting

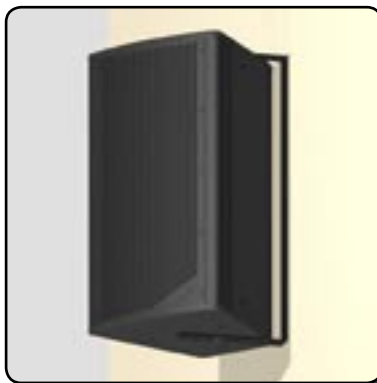

Ceiling mounting

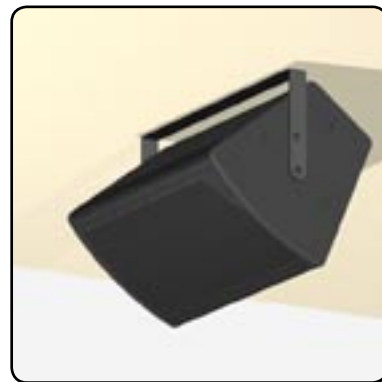
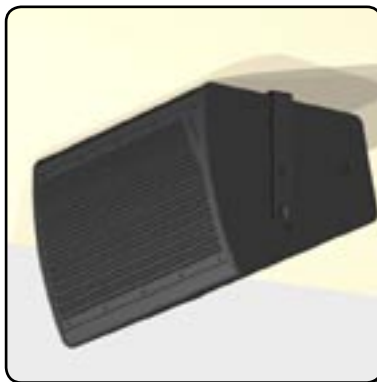

How to mount speaker with eyebolts

For some installations, especially of the larger speakers in the C-range, the ideal way to mount the speaker is by hanging the cabinet in a wire or chain attached to the speaker with an eyebolt.

All mounting points use standard 10mm metric thread for maximum flexibility. To screw an eyebolt into the cabinet, first select where to position the bolt and unscrew the blind bolt already in place. The eyebolt should be tightened with no more than 5 NM (3.7 ft-lbs).

The certified maximum load for the standard Mach eyebolt is 4000 kilograms (8800 lbs).



Warning! Make sure that you comply with all local health and safety regulations when you fly a product.

Horizontal flying



Vertical flying



Rotatable horn

The CM12, CM15 and CM18 feature a rotatable horn that allows the speaker to be flown vertically or horizontally and still maintain the required dispersion. The default positioning of the horn is for horizontal installation. If vertical installation is required remove the grille and unscrew the horn base-plate (On the CM12 unscrew the actual horn). The horn can now be rotated 90 degrees to achieve the required dispersion.

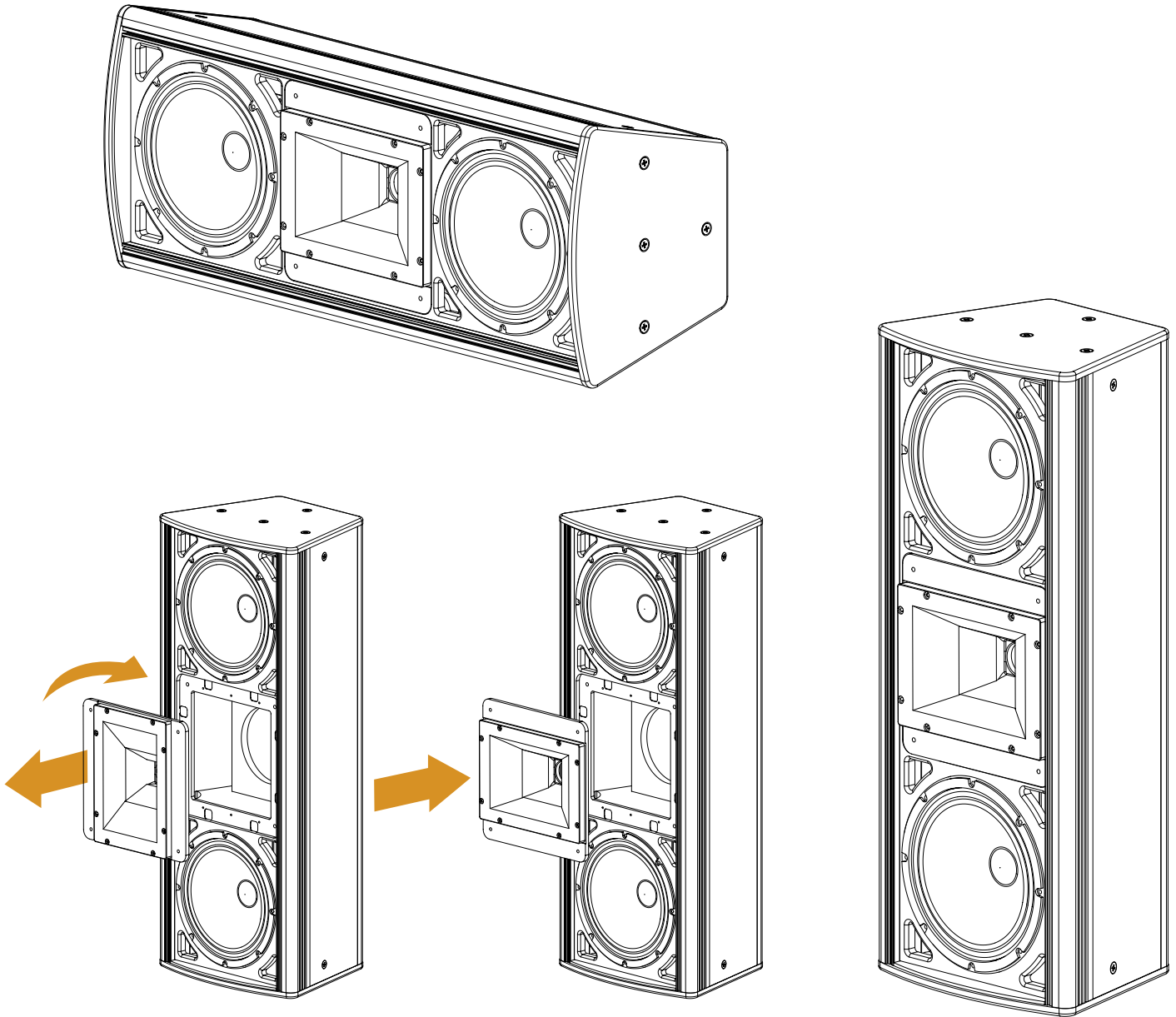

Horn protection

The horn features a thermal protection circuit that increases the impedance when the current exceeds a safe level. The increased impedance reduces current to the horn, thus protecting it against damage. The audible result is lower output from the horn. When this happens, *do not increase the high frequency level on the EQ or tone control*, as this may cause damage to the protection circuit and possibly also the diaphragm.

When the current returns to a safe level, the protection circuit restores full signal current to the horn, and the audio output returns to normal.

The thermal protection is very efficient as it combines good protection with excellent sound quality. The components in the protection circuit are all linear and thus have no influence on the sound when not engaged.

Connection

The C-range has a flexible and user-friendly connection module with double connectors, which gives the user the choice of using NL-4 connectors or screw terminals.

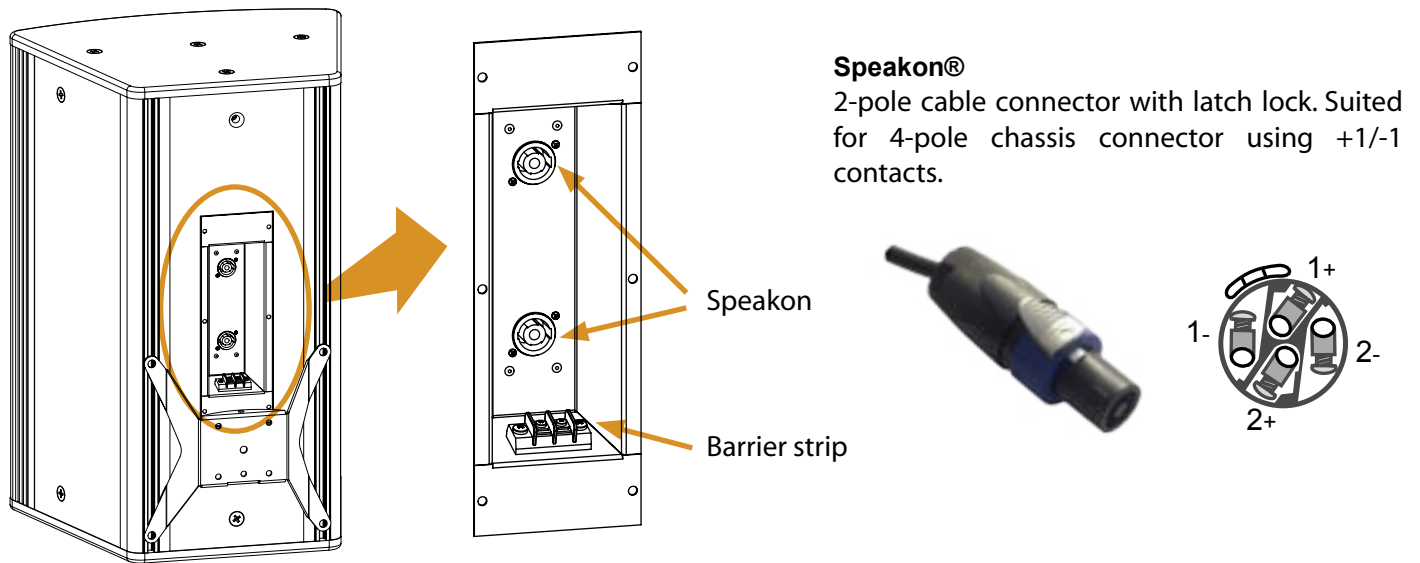

How to connect speaker cable to barrier strip terminals

The barrier strip terminals are a quick and easy way to connect the speaker to an amplifier without using a connector. When using the barrier strip terminals you can either connect a stripped wire or fit a U-type cable shoe on the end of the wire as illustrated.

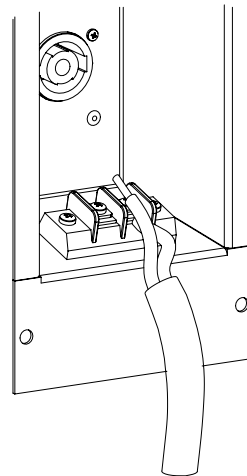

How to attach safety wire

The safety wire is attached to the speaker at one end and to the wall at the other. To mount the safety wire to the speaker please follow the procedure sketched below.

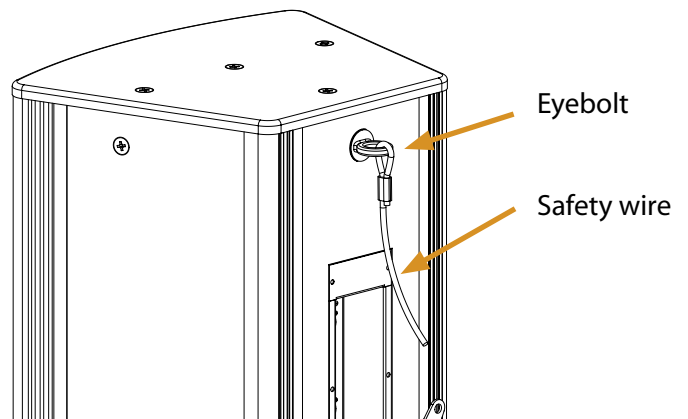
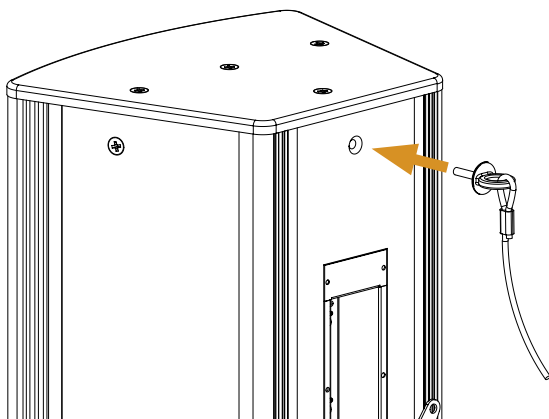

Connecting to amplifiers and system configurations

The way you connect your C-range speakers to your amplifier depends on the type of installation that you are making and the type of amplifier used.

Cables

To get the best possible performance from your C-range speaker, use high quality cable. Cables with high capacitance, high inductance and high impedance have a strong negative influence on sound quality as well as amplifier reliability.

Mach Speakers A/S recommend 2x4 mm (11 AWG) or 4x4 mm (11 AWG) Mach speaker cable. This is a professional rubber cable that is waterproof, has low impedance, low inductance and low capacitance. It also has a low sulfur content that ensures minimum cable oxidation. The cable is very soft and easy to wind. For recommended cable lengths, please see table.

Cable size/load	8 ohms	4 ohms	2 ohms
1.5# (16 AWG)	15 m (50 ft.)	7.5 m (25 ft.)	4 m (13 ft.)
2.5# (14 AWG)	30 m (100 ft.)	15 m (50 ft.)	7.5 m (25 ft.)
4.0# (12 AWG)	60 m (200 ft.)	30 m (100 ft.)	15 m (50 ft.)

Recommended cable lengths (damping factor = 50)

Simple connection CN12

The most basic type of connection is a direct connection from one channel on the amplifier to one speaker. In this case connect the [+] terminal on the amplifier to the [+] terminal on the speaker and the [-] terminal on the amplifier to the [-] terminal on the speaker.

Note! All configurations are illustrated with one channel

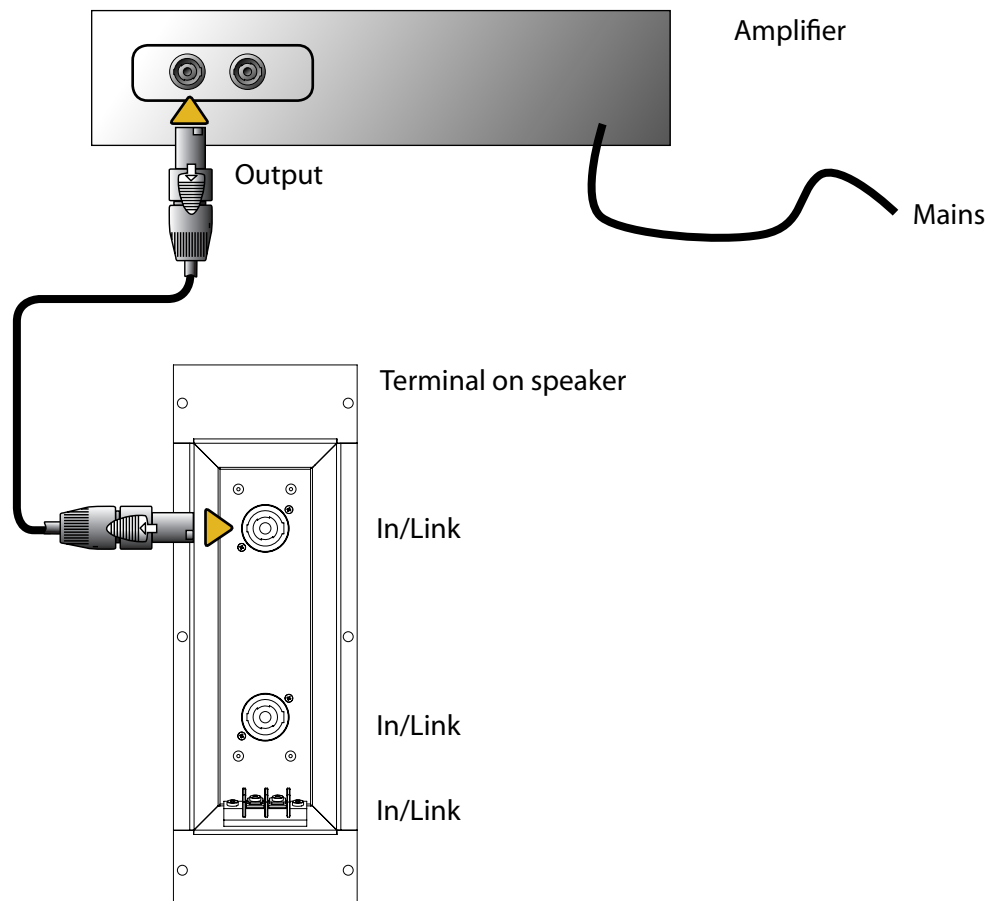

Parallel system CN12

If you require more speakers for better sound distribution and you only have a limited number of output channels on your amplifier, you can connect more than one speaker to each channel. This can be done by linking the speakers for each channel in parallel as illustrated. However, always remember to check the minimum loading impedance specified for the amplifier. The maximum number of identical C-range speakers that can be connected to each amplifier channel is the impedance of the speaker divided by the minimum specified speaker impedance rating of the amplifier (often 4 ohms).

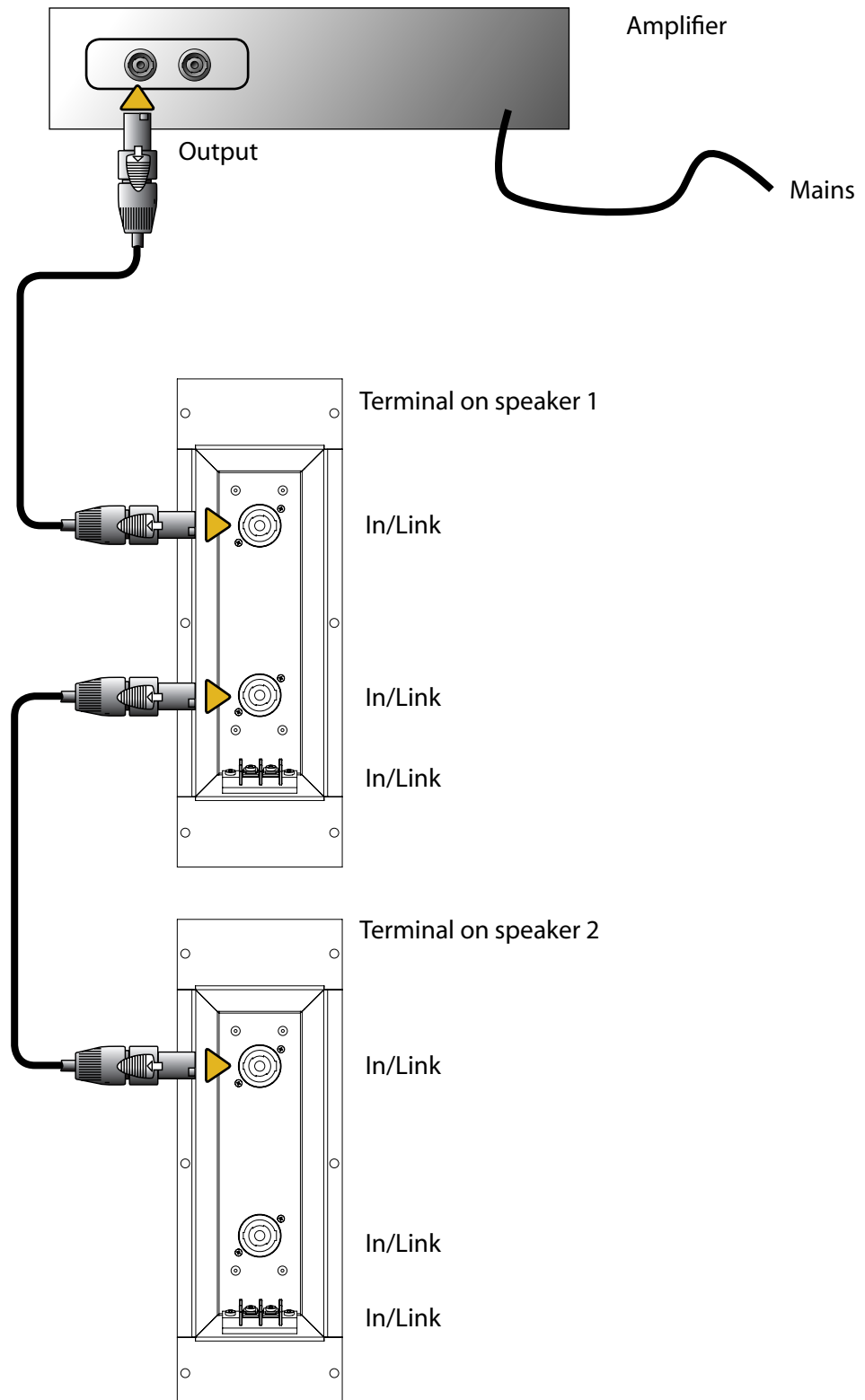

System configuration

For maximum flexibility, all Mach CM speakers can run either passive, using the built-in crossover, or active/biamped with direct drive of each transducer. The speakers are all set up as passive from the factory, but can easily be switched over to active mode at a later stage.

Passive mode

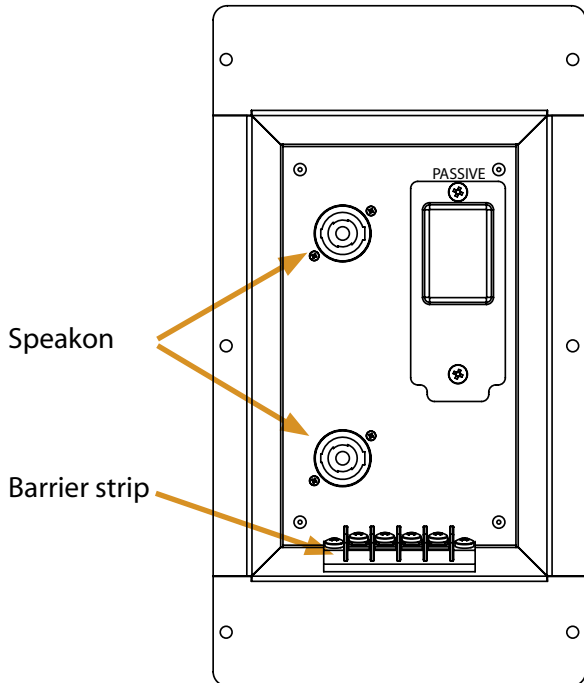

Active mode

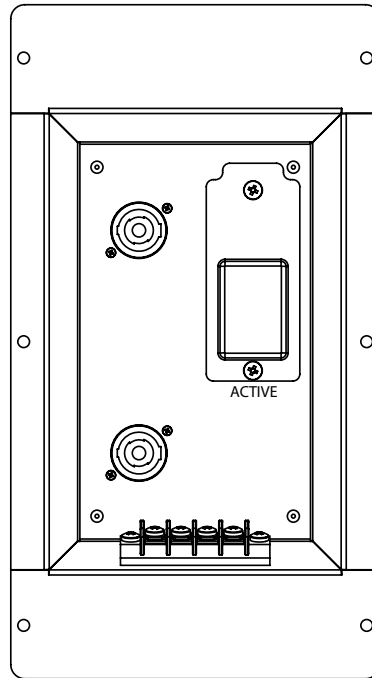

Passive mode setup

Input Speakon pin 1+1-

While operating in passive mode the connectors on the terminal plate will work as shown below:

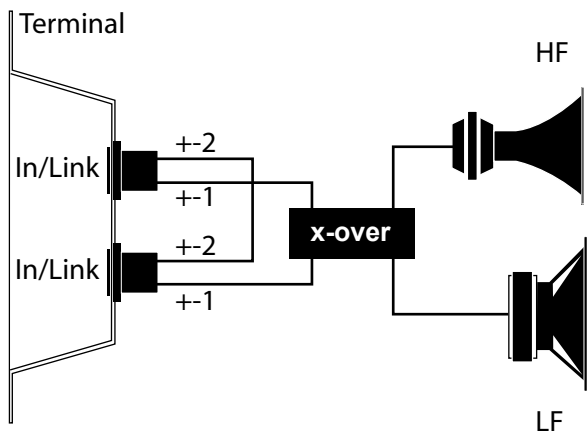

Active mode setup

Input LF 1+1-
Input HF 2+2-

While operating in active mode the connectors on the terminal plate will work as shown below:

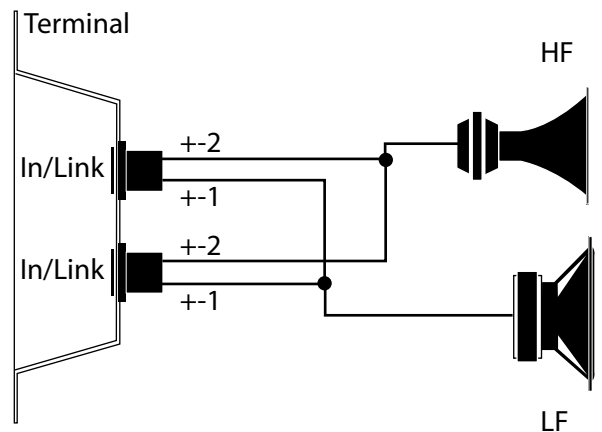

Switching between Passive and Active mode

For the CM series Mach has developed a completely new, extremely safe and user friendly way to switch between Passive and Active mode. The procedure is very quick and simple:

1. Unscrew the lid on the terminal plate with the two screws
2. Remove the Molex connector from the passive socket
3. Insert the Molex connector into the active socket
4. Turn the lid 180 degrees
5. Reposition the lid on the terminal plate
6. The graphics on the plate will now clearly indicate the selected operation mode

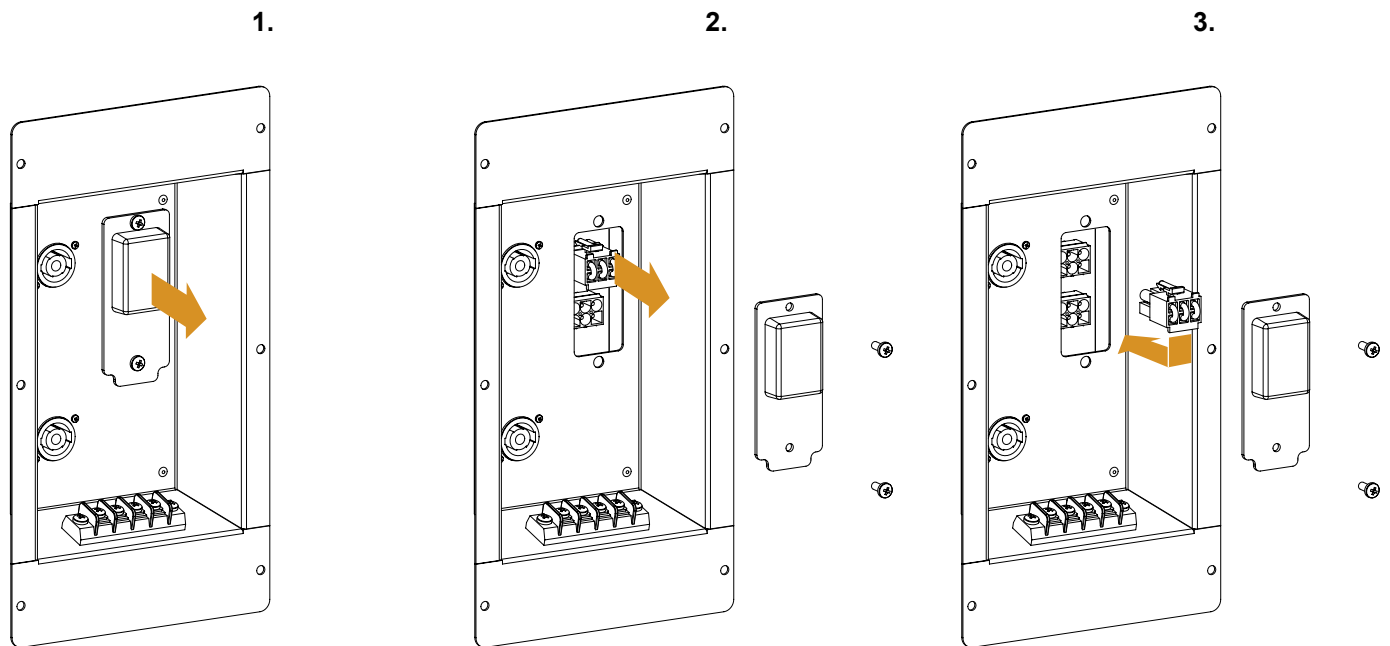

Passive mode

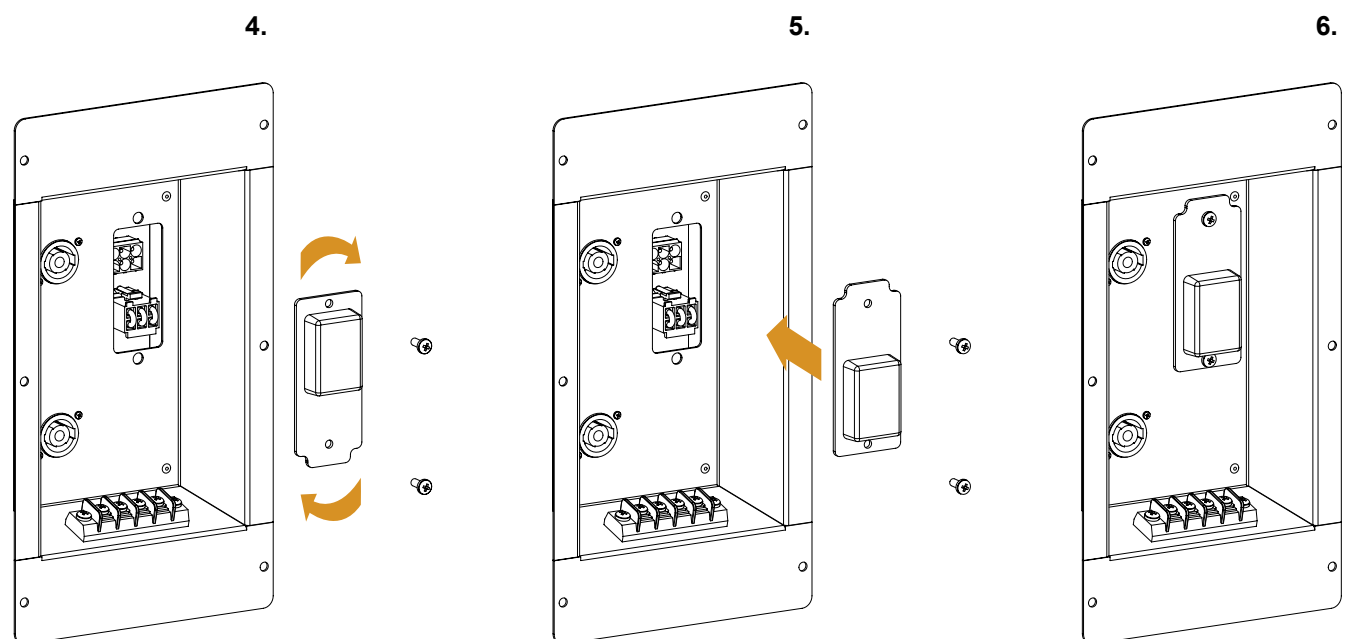

Active mode

Parallel system in passive mode CM12, CM15 and CM18

If you require more speakers for better sound distribution and you only have a limited number of output channels on your amplifier, you can connect more than one speaker to each channel. This can be done by linking the speakers for each channel in parallel as illustrated. However, always remember to check the minimum loading impedance specified for the amplifier. The maximum number of identical C-range speakers that can be connected to each amplifier channel is the impedance of the speaker divided by the minimum specified speaker impedance rating of the amplifier (often 4 ohms).

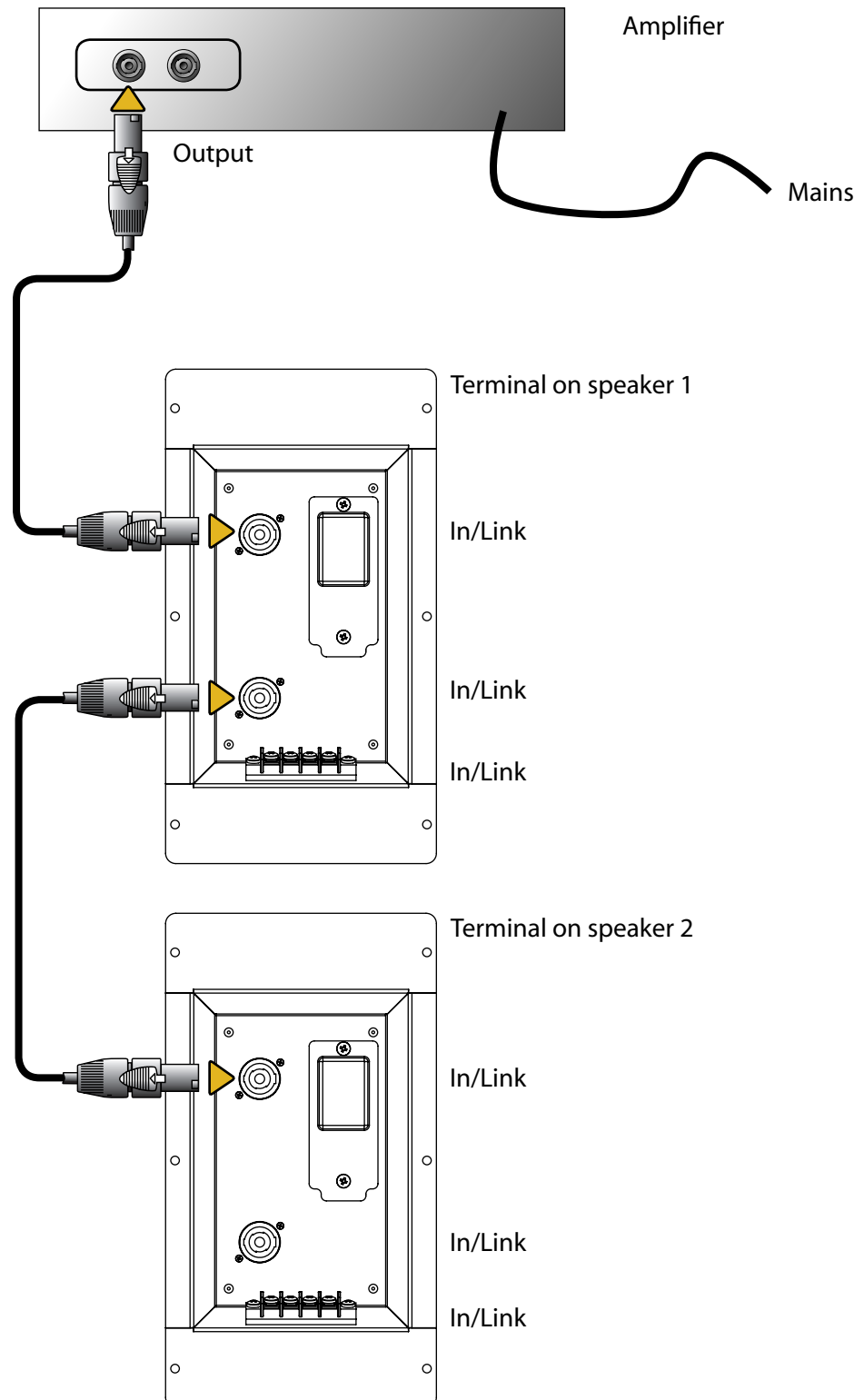

Bi-amp 2-way

In bi-amp 2-way configurations each transducer is driven by a separate amplifier and the system is crossed over directly by the M20.06 for 2-way full range output.

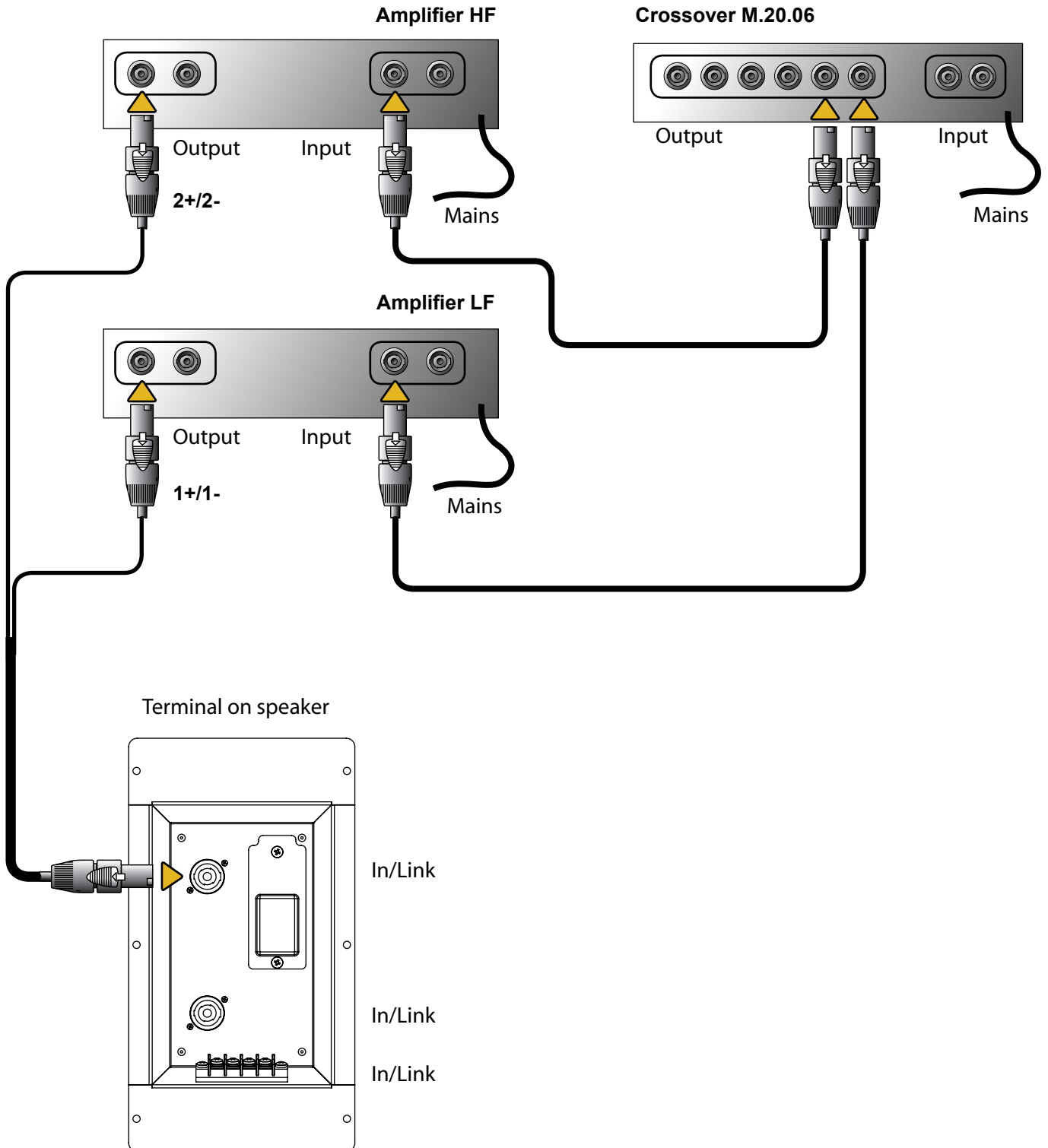

Triple-amp 3-way

In a triple-amp 3-way system each transducer is run by a separate amplifier and all signal modulation is done by the M20.06.

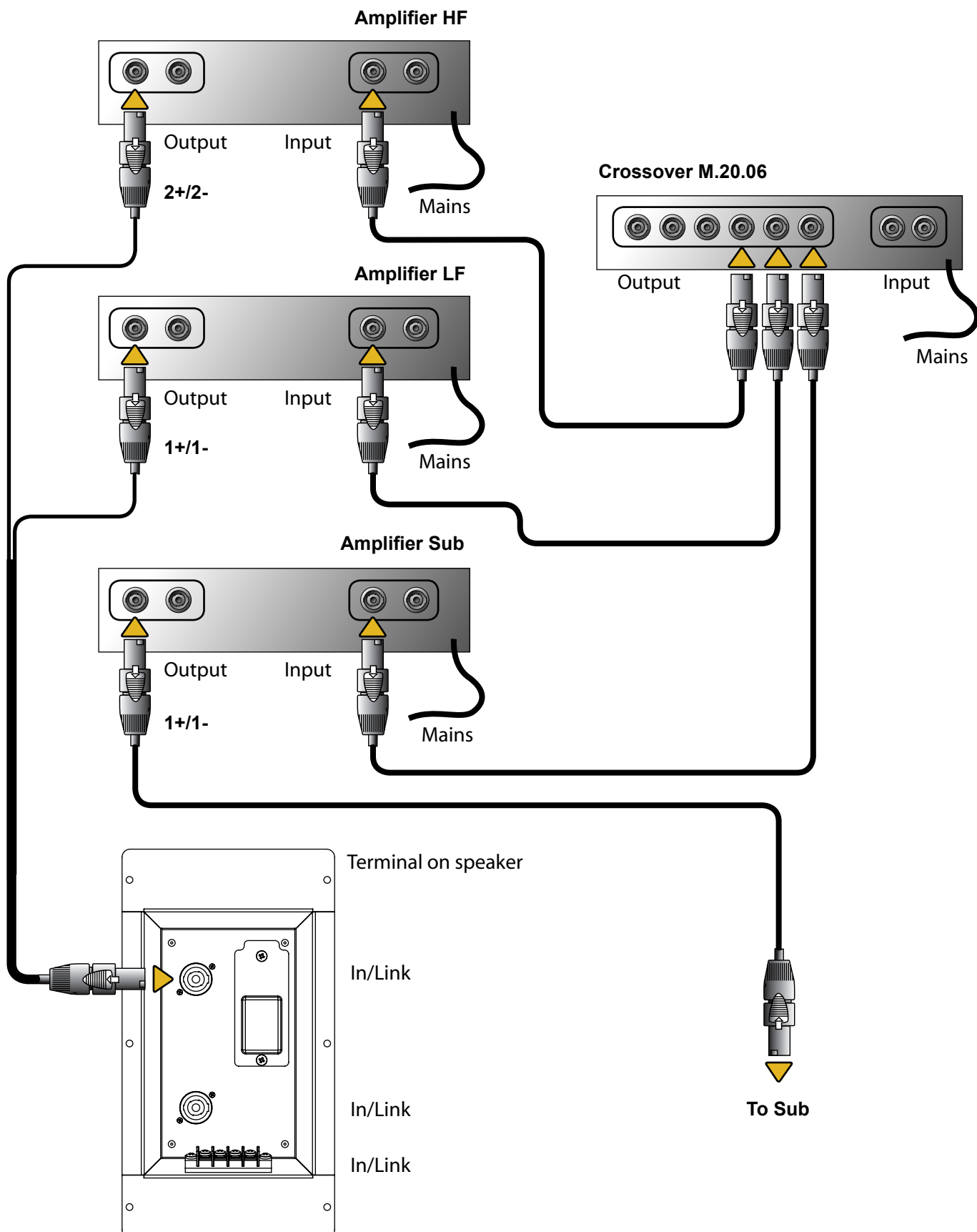

Painting the speaker

The C-range cabinets are made of MDF coated with Mach Safecoat and can easily be painted to match the color scheme of your venue.

To paint your speaker please follow the procedure below:

1. Remove the front grille
2. Degrease the cabinet on all surfaces with denatured alcohol/methylated spirit
Warning: Use of other types of cleaning chemicals can damage the cabinet and should be avoided
3. Mask all areas that should remain unpainted (tweeter, woofer, switch, terminals, reflex port etc)
4. Paint the speaker with Etching primer 2K, P565-713, chromate-free, or a similar product
5. Let the primer dry
6. Apply paint in thin layers using a paint spraying device
7. When spraying the grille be very careful not to fill any holes, as this will have a serious impact on sound quality
8. Let the paint dry
9. Remove masking
10. Put the grille back in place

Maintenance of speakers

Although speaker systems normally only require very limited maintenance there are several things you can do to ensure that your Mach system sounds as good 3 years after installation as on the day you bought it:

Never overload your system – stay within the specified limits for power handling.

Always keep the speaker clean and dry.

As with any electrical product, currents will accelerate corrosion of metal surfaces. Therefore, it is recommended to check the terminals for corrosion at regular intervals, especially if the speaker is mounted in a hostile environment.

How to remove grille

Remove the screws in the grille and pull the grille out. When replacing the grille do not over-tighten the screws.

How to change drivers/woofers

Remove the grille, then remove the screws in the drivers/woofers and pull them out. Carefully disconnect the wires and connect them to the new transducers, tighten the screws and refit the grille.

How to remove spider bracket

Unscrew the four bolts and remove the spider and the washer, then replace the bolts in the nuts and tighten.

How to remove terminal module

Loosen the six screws and pull the terminal out. Note the positions of the wires, then carefully disconnect the wires from the transducers.

How to change crossover

Remove the terminal, note the position of the wires then carefully disconnect the wires from the transducers. Loosen the two screws on each Speakon socket, undo the four screws from the crossover and remove the crossover from the terminal.

Technical information

CN12

A unique, full range near-field speaker combining hi-fi properties with medium SPL in a compact design. Featuring 18 flying points - four of which are fully adjustable - and eyebolts included as standard with every speaker, the C-Range is an extremely versatile installation speaker series. The distinct new CN12 in the C-Range speaker series from MACH powerfully projects every nuance of pure sound in any environment you choose.

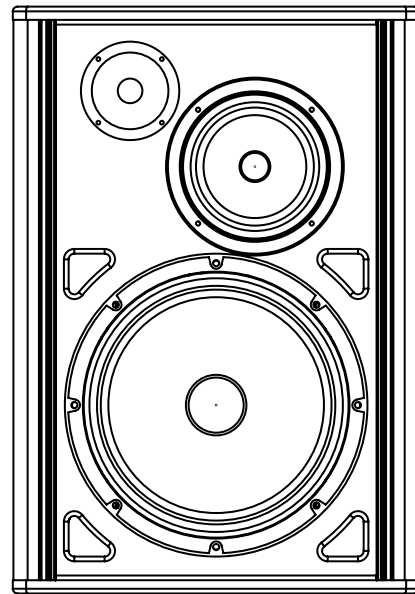

SPECIFICATIONS

Power rating IEC268: 320 watt
Power rating peak: 1280 watt
Sensitivity 1w/1m: 97 dB
Max SPL, calculated long term: 122 dB
Max SPL, peak: 128 dB
Frequency response +/-3dB: 72 Hz - 18 kHz
Dispersion Angle: H 100deg x V 65degrees
Nominal impedance: 8 ohm
Recommended amplifier: 450 watt in 8 ohm

WEIGHT & MEASUREMENTS:

Dimensions (HxWxD): 62 x 43 x 35cm
(24.4 x 16.9 x 13.8 inches)
Net weight: 26.5kg (58.3 lbs)
Finish: Black SafeCoat coating
with other colors optional
Grille: 2 mm steel with foam backing
Input connectors: 2 x Speakon® NL 4
and barrier strip terminals
Rigging hardware: U-bracket part no. 93943010
Eyebolt part no. 93940002

- Unique, full range near-field speaker combining hi-fi properties with medium SPL in a compact design
- A 3-way speaker designed as a compact stand-alone cabinet with a highly controlled dispersion pattern
- One 12" woofer with an extended frequency response
- 1" dome tweeter with phaseplug
- Designed specifically for applications in which clarity and speech intelligibility are needed
- Ideal for small to medium-sized venues (bars, cafés, etc.) or as in-fill in seating areas
- Can be used as a stand-alone solution or in combination with a subwoofer

CM12

A unique medium-throw speaker in a compact design with high output and a controlled dispersion pattern. The CM12 is a dedicated top box and is ideal for applications in small to medium-sized venues. Featuring a rotatable horn and 18 flying points - four of which are fully adjustable - the CM12 is an extremely versatile installation speaker allowing for full flexibility in vertical and horizontal positioning. The distinct new CM12 in the C-Range speaker series from MACH powerfully projects every nuance of pure sound in any environment you choose.

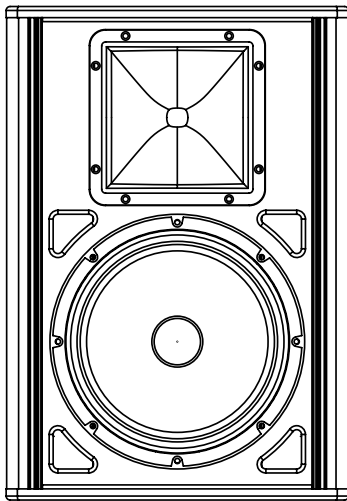

- Unique medium-throw speaker capable of reproducing high SPL
- Dedicated top box holding a powerful 12" woofer and 1" compression driver with a constant coverage horn with low distortion
- Rotatable horn with a 90 x 75 degree dispersion allowing for complete versatility in vertical and horizontal mounting
- Innovative Passive and Active bi-amp solution with secure access to switch and ultra quick change over between modes
- Designed specifically for small to medium-sized venues where high output and low ceiling fixing points are required

SPECIFICATIONS

Power rating IEC268: 325 watt

Power rating peak: 1300 watt

Sensitivity 1w/1m: 98.5 dB

Max SPL, calculated long term: 124 dB

Max SPL, peak: 130 dB

Dispersion Angle: H 90deg x V 75degrees. Horn rotatable

Frequency range +/-3dB: 70 Hz - 18 kHz

Nominal impedance: 8 ohm

Recommended High Pass filter: 100Hz (24dB/octave)

Recommended controller: Mach M20.06

Recommended amplifier: 450 watt in 8 ohm

Drive units:

Woofer: 1x12" with an interleaved sandwich voice coil

Nominal impedance: 8 ohm

Powerhandling AES: 350 watt

Sensitivity 1W/1m: 99.5dB

Max SPL, calc. long term: 125dB

Max SPL, peak: 131dB

Recommended High Pass filter: 100Hz (24dB/ octave)

Recommended amplifier: 500 watt in 8 ohm

Compression driver: 1" exit with polyester diaphragm

Nominal impedance: 8 ohm

Powerhandling above 1.6kHz/24dB/ oct: 80 watt

Sensitivity 1W/1m: 107dB

Max SPL, calc. Long term: 126dB

Max SPL, peak: 132dB

Recommended crossover freq: 1600Hz/ 24dB/ oct

Recommended amplifier: 115 Watt in 8 ohm

Recommended controller: Mach M20.06

Weight & Measurements:

Dimensions (HxWxD): 62x43x35cm (24.4x16.9x13.8in)

Net weight: 26.5 kg (58.3 lbs)

Finish: Black SafeCoat coating. Other colors optional.

Grille: 2 mm steel with foam backing

Input connectors: 2 x Speakon® NL4, and barrier strips

Optional top-hat adapter: 35 mm. diameter

Rigging hardware: Eyebolt part no. 93940002

U-bracket (fixed) part no. 93943010

CM15

A unique medium-throw speaker with very high SPL and controlled dispersion pattern. The CM15 is ideal for medium to large-sized venues and can run either as a top box or as a full range box. Featuring a rotatable horn and 18 flying points - four of which are fully adjustable - the C-Range is an extremely versatile installation speaker allowing for full flexibility in vertical and horizontal positioning. The distinct new CM15 in the C-Range speaker series from MACH powerfully projects every nuance of pure sound in any environment you choose.

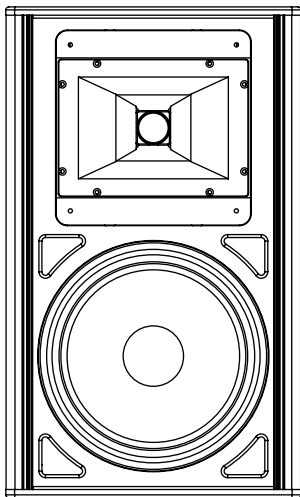

- Unique medium throw speaker capable of reproducing very high SPL with a controlled dispersion pattern
- Top box holding a powerful 15" woofer and 2" compression driver with a constant coverage horn with low distortion. Can run as a full range box
- Rotatable horn with a 90 x 55 degree dispersion allowing for complete versatility in vertical and horizontal mounting
- Innovative Passive and Active bi-amp solution with secure access to switch and ultra quick change over between modes
- Designed specifically for medium to large-sized applications

SPECIFICATIONS

Passive mode:

Power rating IEC268: 450watt

Power rating peak: 1800 watt

Sensitivity 1w/1m: 102 dB

Max SPL, calculated long term: 129 dB

Max SPL, peak: 135 dB

Frequency range +/-3dB: 58 Hz - 20 kHz

Dispersion angle: H90xV55degrees. Horn rotatable

Nominal impedance: 8 ohm

Recommended High Pass filter: 45Hz (24dB/octave)

Recommended Controller: Mach M20.06

Recommended amplifier: 650 watt in 8 ohm

Drive units:

Woofer: 15" with 3" voice coil

Nominal impedance: 8 ohm

Powerhandling AES: 400 watt

Sensitivity 1W/1m 102 dB

Max SPL, calculated long term: 129 dB

Max SPL, Peak 135 dB

Recommended High Pass filter: 45Hz (24dB/octave) or higher

Recommended amplifier: 650 watt

Compression driver: 3" diaphragm, 2" throat

Nominal impedance: 16 ohm

Power handling AES: 150 watt

Sensitivity 1W/1m: 110dB

Max SPL, calculated long term: 132 dB

Max SPL, Peak: 138 dB

Recommended crossover freq: 1400Hz/ 24dB/ oct

Recommended amplifier: 200 watt

Recommended Controller: Mach M20.06

Weight & Measurements:

Dimensions (HxWxD): 83 x 50 x 40.5cm

Net weight: 41.5kg (91.3 lbs)

Finish: Black SafeCoat coating. Other colors optional.

Grille: 2 mm steel with foam backing

Input connectors: 2 x Speakon® NL 4 and barrier strips

Rigging hardware: Eyebolt part no. 93940002

CM18

A unique medium-throw speaker with ultra high SPL and controlled dispersion pattern in an ultra slim design. The CM18 is ideal for large-sized venues with low ceiling fixing points. Featuring a rotatable horn and 18 flying points - four of which are fully adjustable - the C-Range is an extremely versatile installation speaker allowing for full flexibility in vertical and horizontal positioning. The distinct new CM18 in the C-Range speaker series from MACH powerfully projects every nuance of pure sound in any environment you choose.

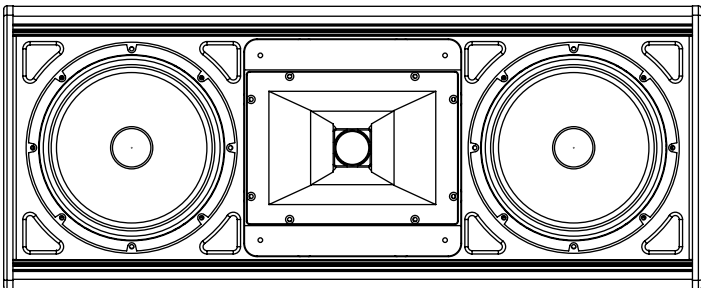

- Unique medium-throw speaker capable of reproducing ultra high SPL with a controlled dispersion pattern
- Top box holding two powerful 12" woofers and a 2" compression driver with a constant coverage horn with low distortion
- Rotatable horn with a 90 x 55 degree dispersion allowing for complete versatility in vertical and horizontal mounting
- Innovative Passive and Active bi-amp solution with secure access to switch and ultra quick change over between modes
- Designed specifically for large-sized applications and is ideal for low ceiling installations when positioned horizontally

SPECIFICATIONS

Passive mode:

Power rating IEC268: 700 watt

Power rating peak: 2800 watt

Sensitivity 1w/1m: 102,5 dB

Max SPL, calculated Long term: 131 dB

Max SPL, peak: 137 dB

Frequency range +/-3dB: 75 Hz - 20 kHz

Dispersion angle: H90 x V55degrees. Horn rotatable

Nominal impedance: 4 ohm

Recommended High Pass filter: 100Hz (24dB/octave)

Recommended Controller: Mach M20.06

Recommended amplifier: 1000 watt in 4 ohm

Drive units:

Woofer: 2x12" with an interleaved sandwich voice coil

Nominal impedance: 4 ohm (2 pcs)

Power handling AES: 700 watt (2 pcs)

Sensitivity 1w/1m: 102.5 dB

Max SPL, calculated long term: 131 dB

Max SPL, peak: 137 dB

Recommended High Pass filter: 100Hz (24dB/octave) or higher

Recommended amplifier: 1000 watt in 4 ohm

Compression driver:

3" diaphragm, 2" throat

Nominal impedance: 16 ohm

Power handling AES: 150 watt

Sensitivity 1w/1m: 110 dB

Max SPL, calculated long term: 132 dB

Max SPL, peak: 138 dB

Recommended crossover freq: 1500Hz/ 24dB/oct

Recommended amplifier: 200 watt in 16 ohm

Recommended controller: Mach M20.06

Weight & Measurements:

Dimensions (HxWxD): 106x43x35 cm

(41.7x16.9x13.8 inches)

Net weight: 45 kg (99 lbs)

Finish: Black SafeCoat coating. Other colors optional

Grille: 2 mm steel with foam backing

Input connectors: 2 x Speakon® NL4 and barrier strips

Rigging hardware: Eyebolt part no. 93940002

Warranty

For information on the warranty conditions specific for your country please refer to the material handed to you by your local Mach distributor.

Declaration of conformity

Manufacturer: MACH Speaker A/S
Perspektivevej 2
9900 Frederikshavn
Denmark

We, MACH Speakers A/S, declare under our responsibility that the following product(s)

Product: CN12/CM12/CM15/CM18
Type: Speaker

Are in conformity with:

- COUNCIL DIRECTIVE of 3 May 1989 on the approximation of the laws of the Member States relating to electromagnetic compatibility (89/336/EEC)

Was manufactured in conformity with the following national standards that implements a harmonized standard:

EN 55013

Limits and methods of measurement of radio disturbance characteristics of broadcast receivers and associated equipment.

Michael Holmbo Michael Holmbo

Date: 27 August 2004

Ordering spare parts

In the unlikely event of your speaker breaking down some of the components can be ordered as spare parts.

For information on how to order in your country please contact your local supplier or contact the head office in Denmark at the following address:

Mach Speakers A/S
Perspektivvej 2
DK-9900 Frederikshavn
Denmark
Tel: +45 72150852

Or send an e-mail to: machservice&support@martin.dk

C-range overview

Co-designed by contractors for contractors, the C-range is a breakthrough in installation speaker design and offers extraordinarily easy installation. From full range near-field speakers to medium-throw speakers, the C-range is ideal for many types of venues such as bars, cafés and large live or playback venues.

CN7

Specifications:

Power rating IEC268: 150 watt
Power rating peak: 600 watt
Sensitivity 1w/1m: 92 dB
Max SPL, calculated long term: 114 dB
Max SPL, peak: 120 dB
Frequency response +/-3dB: 65 Hz - 17 kHz
Dispersion angle avg. H 100 x V 100 deg
Nominal impedance: 8 ohm
Recommended amplifier: 200 watt in 8 ohm
Dimensions (HxWxD): 41.5 x 34.9 x 33.8 cm
(16.3 x 13.7 x 13.3 inches)
Net weight: 15kg (33 lbs)
Finish: Black coating with other colors optional
Grille: 2 mm steel with foam backing
Input connectors: 2 x Speakon® NL 4,
and barrier strip terminals
Rigging hardware: Included U-bracket



CN8

Specifications:

Power rating IEC268: 300 watt
Power rating peak: 1200 watt
Sensitivity 1w/1m: 95 dB
Max SPL, calculated long term: 120 dB
Max SPL, peak: 126 dB
Frequency response +/-3dB: 65 Hz - 20 kHz
Dispersion Angle: H 90deg x V 60deg
Nominal impedance: 4 ohm
Recommended amplifier: 400 watt in 4 ohm
Dimensions (HxWxD): 62 x 34.9 x 33.8cm
(24.4 x 13.7 x 13.3 inches)
Net weight: 22kg (48.5 lbs)
Finish: Black SafeCoat coating
with other colors optional
Grille: 2 mm steel with foam backing
Input connectors: 2 x Speakon® NL 4
and barrier strip terminals
Rigging hardware: Included U-bracket



CM7

Specifications:

Power rating IEC268: 300 watt
Power rating peak: 1200 watt
Sensitivity 1w/1m: 96dB (avg.)
Max SPL, calculated long term: 121dB
Max SPL, peak: 127 dB
Frequency range +/-3dB: 80 Hz - 20 kHz
Dispersion angle avg. H 90 x V 60 deg
Nominal impedance: 8 ohm
Recommended amplifier: 400 watt in 8 ohm
Dimensions (HxWxD): 41.5 x 34.9 x 33.8 cm
(16.3 x 13.7 x 13.3 inches)
Net weight: 15kg (33 lbs)
Finish: Black SafeCoat coating with other colors optional
Grille: 2 mm steel with foam backing
Input connectors: 2 x Speakon® NL 4 and barrier strip terminals
Rigging hardware: Included U-bracket



CM9

Specifications:

Power rating IEC268: 600 watt
Power rating peak: 2400 watt
Sensitivity 1w/1m: 99dB (avg.)
Max SPL, calculated long term: 127dB
Max SPL, peak: 133 dB
Frequency range +/-3dB: 70 Hz - 20 kHz
Dispersion angle avg. H 90 x V 60 deg
Nominal impedance: 4 ohm
Recommended amplifier: 850 watt in 4 ohm
Dimensions (HxWxD): 70 x 34.9 x 33.8 cm
(27.6 x 13.7 x 13.3 inches)
Net weight: 25kg (55 lbs)
Finish: Black SafeCoat coating with other colors optional
Grille: 2 mm steel with foam backing
Input connectors: 2 x Speakon® NL 4 and barrier strip terminals
Rigging hardware: Included U-bracket



Ci range overview

A perfect complement to the C-range in most retail and club environments is the Mach Ci series. All Mach Ci in-fill speakers have wide, even dispersion that ensures good coverage in low ceiling applications.

Ci 4

Specifications:

Power rating IEC268	50 watt
Power rating peak	200 watt
Recommended amplifier	70 watt
Freq. Range +/-3dB	120Hz-20KHz
Freq. Range +/-10dB	80Hz-20KHz
Sensitivity 1W/1m	87dB
Nominal impedance	8 ohm
Woofers	4"
Tweeter	3/4"
Dispersion	Ø90°
Flying system	TF bracket, Steel mounting bracket
Dimensions (H x W x D)	207x150x120mm (8.15x5.91x4.72in)
Net weight	1.8 Kg (4 lbs)



Ci 6

Specifications:

Power rating IEC268	65 watt
Power rating peak	260 watt
Recommended amplifier	100 watt
Freq. Range +/-3dB	90Hz-20KHz
Freq. Range +/-10dB	70Hz-20KHz
Sensitivity 1W/1m	89dB
Nominal impedance	8 ohm
Woofers	6.5"
Tweeter	3/4"
Dispersion	Ø90°
Flying system	TF bracket, Steel mounting bracket
Dimensions (H x W x D)	275x200x160mm (10.83x7.83x6.30in)
Net weight	2.7 Kg (5.9 lbs)



Ci 8

Specifications:

Power rating IEC268	125 watt
Power rating peak	500 watt
Recommended amplifier	175 watt
Freq. Range +/-3dB	70Hz-20KHz
Freq. Range +/-10dB	60Hz-20KHz
Sensitivity 1W/1m	93dB
Nominal impedance	8 ohm
Woofers	8"
Tweeter	1"
Dispersion	Ø90°
Flying system	TF bracket, Steel mounting bracket
Dimensions (H x W x D)	395x290x220mm (15.55x11.42x8.66in)
Net weight	5.2 Kg (11.5 lbs)



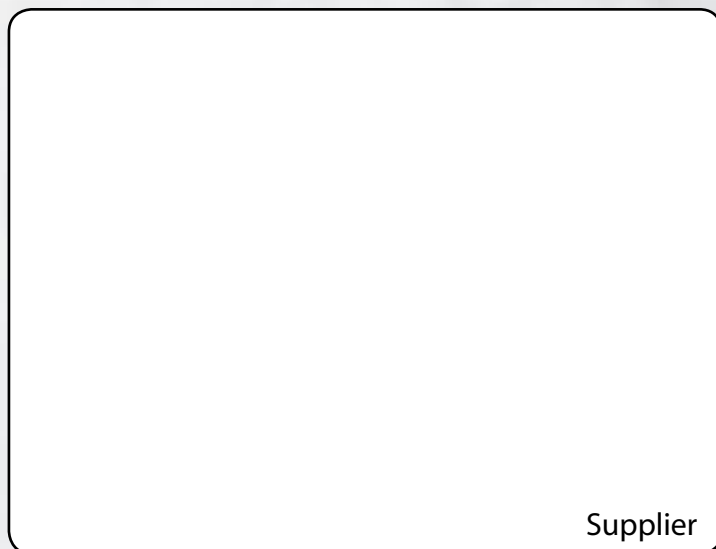

Supplier

Mach Speakers A/S

www.mach.dk