

MH 4 Beam

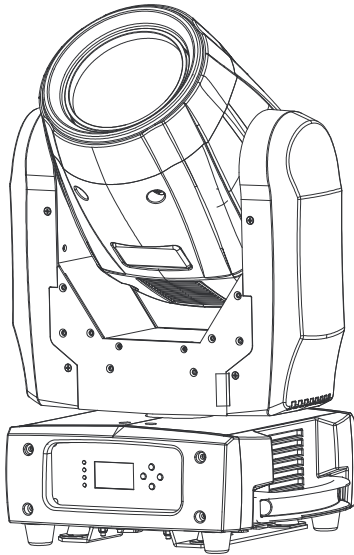

User Manual



by Martin®

Professional Entertainment Technology

© 2013-2014 Martin Professional ApS. Information subject to change without notice. Martin Professional and all affiliated companies disclaim liability for any injury, damage, direct or indirect loss, consequential or economic loss or any other loss occasioned by the use of, inability to use or reliance on the information contained in this manual. The Martin logo, the RUSH by Martin logo, the RUSH by Martin name, the Martin name and all other trademarks in this document pertaining to services or products by Martin Professional or its affiliates and subsidiaries are trademarks owned or licensed by Martin Professional or its affiliates or subsidiaries.

Martin Professional • Olof Palmes Allé 18 • 8200 Aarhus N • Denmark • www.martin.com

Manual: Revision F

Table of contents

Safety information	4
Introduction	10
Before using the product for the first time	10
Physical installation	11
Fastening the fixture to a flat surface	11
Mounting the fixture on a truss	11
Securing with a safety cable	12
AC power	13
Linking fixtures to power in a chain	14
Fixture overview	14
DMX data link	15
Connecting the data link	16
Fixture setup	16
Using the control panel	16
DMX function settings	17
Fixture settings	17
Lamp settings	18
Display settings	19
Fixture tests	21
Fixture information	22
Special functions	23
Effect home position (offset) adjustment	23
Effects	25
Lamp control	25
Pan and tilt	25
Dimming	25
Strobe effects	26
Gobos	26
Prism	27
Color wheel	27
Maintenance	28
Cleaning	28
Replacing the lamp	29
Fuse replacement	31
DMX protocol	32
Control menus	37
Offset menu	40
Error messages	41
Troubleshooting	42
Specifications	44

Safety information



WARNING!

Read the safety precautions in this manual before installing, powering, operating or servicing this product.

The following symbols are used to identify important safety information on the product and in this manual:



Warning!

Safety hazard. Risk of severe injury or death.



Warning!

Powerful light emission. Risk of eye injury.



Warning!

Refer to manual for important safety information.



Warning!

Hazardous voltage. Risk of lethal or severe electric shock.



Warning!

Hot surfaces and fire hazard.



Warning! Risk Group 2 product according to EN 62471. Avoid looking directly into the beam and do not view the light output with optical instruments or any device that may concentrate the beam.



This lighting fixture is for professional use only – it is not for household use. The fixture must be installed by a qualified technician. The safety of the installation is the responsibility of the installer. The fixture presents risks of severe injury or death due to fire hazards, electric shock and falls. It produces a powerful, concentrated beam of light that can create a fire hazard or a risk of eye injury if the safety precautions below are not followed.

If you have any questions about how to install, operate or service the fixture safely, please contact your Martin™ distributor (see www.martin.com/distributors for details) or call the Martin™ 24-hour service hotline on +45 8740 0000, or in the USA on 1-888-tech-180.

Respect all locally applicable laws, codes and regulations when installing, operating or servicing the fixture.

Refer any service operation not described in this manual to an authorized Martin™ service technician. Do not try to carry out any such operation yourself, as doing so may present a health or safety risk. It may also cause damage or malfunction and it may void your product warranty.



Install, operate and service RUSH by Martin™ products only as directed in their user manuals, or you may create a safety hazard or cause damage that is not covered by product warranties.

Follow the safety precautions listed below and observe all warnings in this manual and printed on the product. Keep this manual for future use.

For the latest user documentation and other information about this and all Martin™ products, please visit the Martin website at <http://www.martin.com>



Protection from electric shock

Do not expose the fixture to rain or moisture.

Disconnect the fixture from AC power before carrying out any installation or maintenance work, such as changing the lamp, and when the fixture is not in use.

Ensure that the fixture is electrically connected to ground (earth).

Use only a source of AC power that complies with local building and electrical codes and has both overload and ground-fault (earth-fault) protection.

Socket outlets or external power switches used to supply the fixture with power must be located near the fixture and easily accessible so that the fixture can easily be disconnected from power.

Replace defective fuses with ones of the specified type and rating only.

Isolate the fixture from power immediately if the power plug or any seal, cover, cable, or other component is damaged,

defective, deformed, wet or showing signs of overheating. Do not reapply power until repairs have been completed.

Before using the fixture, check that all power distribution equipment and cables are in perfect condition and rated for the current requirements of all connected devices.

Use only Neutrik PowerCon cable connectors to connect to the fixture's power sockets.

Do not connect devices to power in a chain that will exceed the electrical ratings of any cable or connector used in the chain.

The supplied power input cable is rated 6 A and can safely supply only one fixture with mains power. Do not connect any device to the fixture's MAINS OUT connector when using this cable. If you replace this cable and also use the replacement cable to supply only one fixture with mains power, the replacement cable must also be rated 6 A minimum, have three conductors 18 AWG or 0.75 mm² minimum conductor size, have an outer cable diameter of 6 - 15 mm (0.2 - 0.6 in.) and be temperature-rated to suit the application. In the USA and Canada the cable must be UL listed, type SJT or equivalent. In the EU the cable must be type H05VV-F or equivalent.

To connect fixtures to mains power in a chain, you must first obtain 14 AWG or 1.5 mm² power input and throughput cables that are 16 A rated and temperature-rated to suit the application. In the USA and Canada the cables must be UL-listed, type SJT or equivalent. In the EU the cables must be type H05VV-F or equivalent. Suitable cables with Neutrik PowerCon connectors are available from Martin™ (see 'Accessories' on page 46). If you use these cables, you can connect fixtures to power in a linked chain, MAINS OUT throughput socket to MAINS IN input socket, but do not link more than:

- five (5) RUSH MH 4 fixtures in total at 100-120 V, or
- ten (10) RUSH MH 4 fixtures in total at 200-240 V.

The voltage and frequency at the MAINS OUT socket are the same as the voltage and frequency applied to the MAINS IN socket. Only connect devices to the MAINS OUT socket that accept this voltage and frequency.



Protection from burns and fire

Do not use the fixture to illuminate surfaces within 6.5 m (21.3 ft.) of the fixture.

Do not operate the fixture if the ambient temperature (T_a) exceeds 40° C (104° F).

The surface of the product casing can reach up to 90° C (194° F) during operation. Avoid contact by persons and materials. Allow the fixture to cool for at least 60 minutes before handling.

Keep flammable materials well away from the fixture. Keep all combustible materials (e.g. fabric, wood, paper) at least 100 mm (4 in.) away from the fixture head.

Ensure that there is free and unobstructed airflow around the fixture. Provide a minimum clearance of 100 mm (4 in.) around fans and air vents.

Do not attempt to bypass thermostatic switches or fuses.

Do not stick filters, masks or other materials onto any optical component.



Lamp safety

Install only a lamp that is approved for use in the product.

Prolonged exposure to an unshielded discharge lamp can cause eye and skin burns. Do not stare directly into the light output.

Never look at an exposed lamp while it is lit.

Do not operate the fixture with missing or damaged covers, shields, lenses, ultraviolet screens or any optical component.

A hot discharge lamp is under pressure and can explode without warning. Allow the fixture to cool for at least 2 hours and protect yourself with safety glasses and gloves before handling a lamp.

Replace the lamp immediately if it becomes visually deformed, damaged or in any way defective.

Monitor hours of lamp use and lamp intensity and replace the lamp when it reaches the limit of its service life as specified in this manual or by the lamp manufacturer.

If the quartz envelope of a discharge lamp is broken, the lamp releases a small quantity of mercury and other toxic gases. If a



discharge lamp explodes in a confined area, evacuate the area and ventilate it thoroughly. Wear nitrile gloves when handling a broken discharge lamp. Treat broken or used discharge lamps as hazardous waste and send to a specialist for disposal.



Protection from eye injury

The fixture emits infrared and ultraviolet rays that are not normally visible but that may be harmful to the eyes and skin. Do not stare at an operating lamp. Minimize exposure to eyes or skin. Use appropriate shielding or eye protection.

Do not look directly into the light beam. Do not point the beam in a direction where a person can look directly into it.

Ensure that persons are not looking at the light beam when the product lights up suddenly. This can happen when power is applied, when the product receives a DMX signal, or when certain control menu items are selected.

Do not look at the light output with magnifiers, telescopes, binoculars or similar optical instruments that may concentrate the light output.

To minimize the risk of eye irritation or injury, disconnect the fixture from power at all times when the fixture is not in use, and provide well-lit conditions to reduce the pupil diameter of anyone working on or near the fixture.

Do not operate the fixture with missing or damaged covers, shields or any optical component. If shields, lenses or ultraviolet screens have become visibly damaged to such an extent that their effectiveness is impaired, for example by cracks or deep scratches, return the fixture to an authorized Martin™ service agent for replacement.



Protection from injury

Fasten the fixture securely to a fixed surface or structure when in use. The fixture is not portable when installed.

Ensure that any supporting structure and/or hardware used can hold at least 10 times the weight of all the devices they support.

If suspending from a rigging structure, fasten the fixture to a rigging clamp. Do not use safety cables as the primary means of support.

If the fixture is installed in a location where it may cause injury or damage if it falls, install as directed in this manual a secondary attachment such as a safety cable that will hold the fixture if a primary attachment fails. The secondary attachment must be approved by an official body such as TÜV as a safety attachment for the weight that it secures, must comply with EN 60598-2-17 Section 17.6.6 and must be capable of bearing a static suspended load that is ten times the weight of the fixture and all installed accessories.

Allow enough clearance around the head to ensure that it cannot collide with an object or another fixture when it moves.

Check that all external covers and rigging hardware are securely fastened.

Block access below the work area and work from a stable platform whenever installing, servicing or moving the fixture.

Do not lift or carry the fixture by its head. Always ensure that the fixture is supported by its base.

In the event of an operating problem, stop using the fixture immediately and disconnect it from power. Never attempt to use a fixture that is obviously damaged.

Do not modify the fixture or install other than genuine RUSH by Martin™ parts.

Introduction

The RUSH MH 4 Beam™ is a compact-beam moving head, equipped with an MSD Platinum 2R lamp in a state-of-the-art optical system. The device is extremely rugged, lightweight and compact, ideal for smaller venues.

The fixture produces an intense and narrow beam for spectacular mid-air looks and effects. It houses a fixed gobo wheel and color wheel with a multitude of effects possible from a dimmer and strobe, 6-facet prism and focus.

The fixture can be controlled using any DMX-compliant controller.

The fixture is supplied with a discharge lamp (installed), a 1.5 m (5 ft.) power cable (local power plug not included) and two omega-type mounting brackets.

Before using the product for the first time

1. Read 'Safety information' on page 4 before installing, powering, operating or servicing the fixture.
2. Unpack and ensure that there is no transportation damage before using the fixture. Never attempt to operate a damaged fixture.
3. If the fixture is not going to be hard-wired to an AC mains power source, install a local power plug (not supplied) on the end of the supplied power cable.
4. Before operating, ensure that the voltage and frequency of the local power source match the mains power requirements of the fixture.
5. Check the RUSH support pages on the Martin Professional website at www.martin.com for the most recent user documentation and technical information for the fixture. RUSH by Martin™ user manual revisions are identified by the revision letter at the bottom of the inside cover.

Note that whenever AC mains power is applied to the fixture, it will reset all effects and functions to their home positions. The fixture head will move. This process usually takes around 20 seconds.

Physical installation



Read ‘Safety information’ on page 4 before installing the fixture.

The fixture is designed for indoor use only and must be used in a dry location with adequate ventilation. Ensure that none of the fixture’s ventilation slots are blocked.

Fasten the fixture to a secure structure or surface. Do not stand it on a surface or leave it where it can be moved or fall over. If you install the fixture in a location where it may cause injury or damage if it falls, secure it as directed in this user manual using a securely anchored safety cable that will hold the fixture if the primary fastening method fails.

Do not use the fixture to illuminate surfaces within 6.5 m (21.3 ft.) of the fixture.

Martin™ can supply safety cables and rigging clamps that are suitable for use with the fixture (see ‘Accessories’ on page 46).

Fastening the fixture to a flat surface

The fixture can be fastened to a hard, fixed, flat surface that is oriented at any angle. Ensure that the surface and all fasteners used can support at least 10 times the weight of all fixtures and equipment they will support.

Fasten the fixture securely. If you install the fixture in a location where it may cause injury or damage if it falls, install a safety cable as directed in ‘Securing with a safety cable’ on page 12.

Mounting the fixture on a truss

The fixture can be clamped to a truss or similar rigging structure in any orientation. When installing the fixture hanging vertically down, you can use an open-type clamp such as a G-clamp. When installing in any other orientation, you must use a closed-type rigging clamp such as half-coupler clamp (see illustration on right) that completely encircles the truss chord.



To clamp the fixture to a truss:

1. Check that the rigging structure can support at least 10 times the weight of all fixtures and equipment to be installed on it.

2. Block access under the work area.
3. The fixture is supplied with two omega-type brackets to which rigging clamps can be attached. Check that the rigging clamps are undamaged and approved for the fixture's weight. Bolt a rigging clamp securely to each bracket. The bolts used must be M12, grade 8.8 steel minimum, and fastened with self-locking nuts.
4. Fasten the omega brackets to the base of the fixture using the brackets' quarter-turn fasteners. Turn quarter-turn fasteners a full 90° to lock them (see illustration on right).
5. Working from a stable platform, hang the fixture on the truss and fasten the rigging clamps onto the truss.
6. Secure the fixture with a safety cable as directed below.
7. Check that the head will not collide with other fixtures or objects.

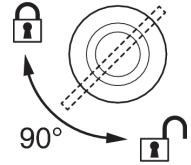

Securing with a safety cable

Secure the fixture with a safety cable (or other secondary attachment) that is approved for the weight of the fixture so that the safety cable will hold the fixture if a primary attachment fails.

Loop the safety cable through the cutout in the fixture's baseplate (arrowed in illustration on right) and around a secure anchoring point.

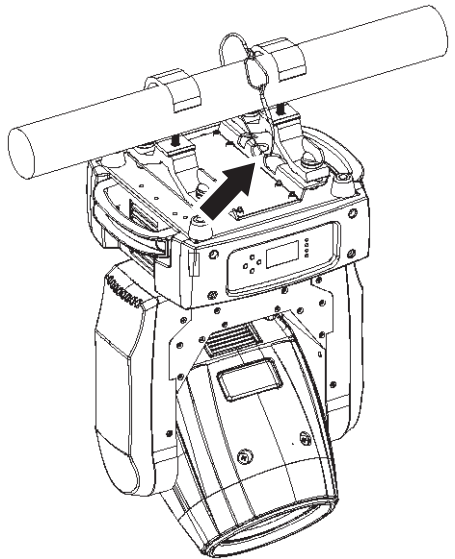

AC power



Read ‘Safety information’ on page 4 before connecting the fixture to AC mains power.



Warning! The mains power input cable supplied with the fixture is rated 6 A and can supply only one fixture with mains power. Do not connect any device to the fixture’s MAINS OUT power throughput socket when using this input cable. If you want to connect other fixtures to the MAINS OUT socket, see ‘Linking fixtures to power in a chain’ on page 14.

For protection from electric shock, the fixture must be grounded (earthed). The power distribution circuit must be equipped with a fuse or circuit breaker and ground-fault (earth-fault) protection.

Socket outlets or external power switches used to supply the fixture with power must be located near the fixture and easily accessible so that the fixtures can easily be disconnected from power.

Do not insert or remove live Neutrik PowerCon connectors to apply or cut power, as this may cause arcing at the terminals that will damage the connectors.

Do not use an external dimming system to supply power to the fixture, as this may cause damage to the fixture that is not covered by the product warranty.

The fixture can be hard-wired to a building electrical installation if you want to install it permanently, or a power plug (not supplied) that is suitable for the local power outlets can be installed on the power cable.

If you install a power plug on the power cable, follow the plug manufacturer’s instructions and connect the wires in the power cable as shown in this table:

	Earth, Ground or 	Neutral or N	Live or L
US system	Green	White	Black
EU system	Yellow/green	Blue	Brown

The fixture has an auto-ranging power supply that accepts AC mains power at 100-240 V at 50/60 Hz. Do not apply AC mains power at any other voltage or frequency to the fixture.

Linking fixtures to power in a chain

If you obtain a 14 AWG / 1.5 mm² power input cable and 14 AWG / 1.5 mm² throughput cables from Martin™ (see 'Accessories' on page 46), you can relay mains power from one fixture to another by connecting fixtures to power in a linked daisy-chain, MAINS OUT throughput socket to MAINS IN input socket.

Using 14 AWG or 1.5 mm² cables from Martin™, you can link:

- Maximum five (5) RUSH MH 4 fixtures to power in a chain at 100-120 V, or
- Maximum ten (10) RUSH MH 4 fixtures to power in a chain at 200-240 V.

Fixture overview

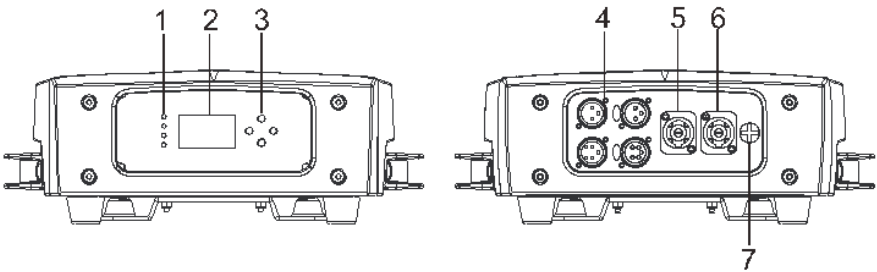

1 - LEDs

The fixture has four LEDs on the front of the base: two are reserved for future use; the other two are marked as follows:

Power	Power on
DMX	Valid DMX signal present

2 – Display

3 – Buttons

MENU	<ul style="list-style-type: none"> • Activate the menu mode functions, or • Return to the previous level of the menu structure, or • Press and hold to exit the menus
DOWN	Go down a menu branch
UP	Go up a menu branch

ENTER	Confirm the selected menu item
-------	--------------------------------

- 4 - DMX XLR input/output sockets:
- 5 – AC mains power IN
- 6 – AC mains power OUT
- 7 – Primary (mains power) fuse F1

DMX data link

A DMX 512 control data link is required in order to control the fixture via DMX. The fixture has 3-pin and 5-pin XLR connectors for DMX data input and output (throughput).

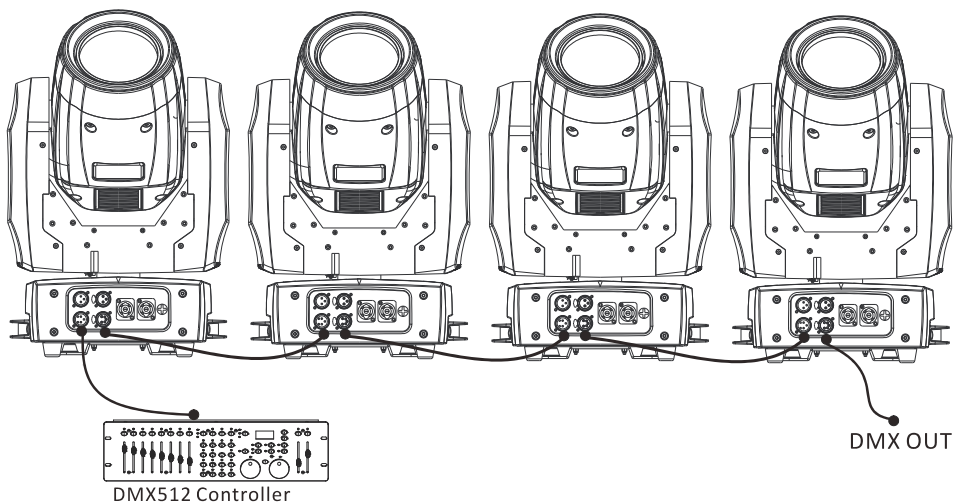

The number of daisy-chained fixtures is limited by the number of DMX channels required by the fixtures in relation to the maximum 512 channels available in one DMX universe. Note that if independent control of a fixture is required, it must have its own DMX channels. Fixtures that are required to behave identically can share the same DMX address and channels. To add more fixtures or groups of fixtures when the above limit is reached, add a DMX universe and another daisy-chained link.

Note that if a fixture loses its DMX signal it will maintain its current effect until powered off or reset.

Tips for reliable data transmission

Use shielded twisted-pair cable designed for RS-485 devices: standard microphone cable cannot transmit control data reliably over long runs. 24 AWG cable is suitable for runs up to 300 meters (1000 ft.). Heavier gauge cable and/or an amplifier is recommended for longer runs. The pin-out on all connectors is pin 1 = shield, pin 2 = cold (-), and pin 3 = hot (+). Pins 4 and 5 in the 5-pin XLR connectors are not used in the fixture but are available for possible additional data signals as required by the DMX512-A standard. Standard pin-out is pin 4 = data 2 cold (-) and pin 5 = data 2 hot (+).

To split the link into branches, use a splitter such as the Martin DMX 5.3 Splitter™ or Martin RDM 5.5 Splitter™. Terminate the link by installing a termination plug in the output socket of the last fixture. The termination plug, which is a male XLR plug with a 120 Ohm, 0.25-Watt resistor soldered between pins 2 and 3, “soaks up” the control signal so it does not reflect and cause interference. If a splitter is used, terminate each branch of the link.

Connecting the data link

To connect the fixture to data:

1. Connect the DMX data output from the controller to the first fixture’s male XLR DMX input connector.
2. Connect the first fixture’s DMX output to the DMX input of the next fixture and continue connecting fixtures output to input. Terminate the last fixture on the link with a DMX termination plug.

Fixture setup

This section explains the options available to change the fixture’s settings. Settings are made using the menus available in the control panel and are retained when the fixture is powered off.

A complete map of the control menu structure and brief explanations of their purposes can be found in ‘Control menus’ on page 37.

Using the control panel

- To access the control menus in the control panel, press the MENU button.
- Navigate the menu structure using the ENTER, DOWN and UP buttons.
- Scroll between menu items using the DOWN and UP buttons.

- Select any required menu option using the ENTER button.
- To return to the previous level in the menu structure without making a change, press the MENU button.
- To exit the menus, press and hold the MENU button.

DMX function settings

DMX function settings include the DMX address and DMX mode.

DMX addressing

The fixture can be controlled using signals sent by a DMX controller over 13 DMX channels. The DMX address, also known as the start channel, is the first channel used to receive instructions from the DMX controller. Each DMX-controlled fixture must have a DMX address set. If a fixture has its DMX address set to 1 and you want to use all 15 channels, then the next fixture can have a DMX address of 16, the next 31, then 46, and so on until the 512 channels in one DMX universe have all been allocated.

For independent control, each fixture must be assigned its own DMX channels. Two fixtures of the same type may share the same address, if identical behavior is desired. Address sharing can be useful for diagnostic purposes and symmetric control, particularly when combined with the inverse pan and tilt options.

To set the fixture's DMX address:

1. Select DMX FUNCTIONS in the control panel and press ENTER.
2. Use the UP and DOWN buttons to select DMX ADDRESS and press ENTER. The fixture's current DMX address will blink in the display.
3. Use the UP and DOWN buttons to select a new address (1 to 512).
4. Once the address has been selected, press ENTER to set it (or to return to the previous menu level without making a change, press MENU).

Viewing DMX values received

DMX FUNCTIONS → View DMX value lets you see the DMX values the fixture is receiving on each of the DMX channels.

Fixture settings

Pan and/or tilt inversion

The FIXTURE SETTINGS → PAN INVERSE and TILT INVERSE menus let you remap the fixture so that the direction of pan and/or tilt are reversed.

These settings are useful for symmetrical effects with multiple fixtures, or when coordinating the movement of fixtures that are floor-mounted and rigged upside down.

Pan/tilt feedback

If you enable pan and tilt feedback in the FIXTURE SETTINGS → P/T FEEDBACK menu, the fixture will correct its pan and tilt positions if it detects a position error.

Blackout during effect changes or movement

You can set the fixture to deploy the shutter to black out light output during pan and tilt movement, gobo changes and/or color changes. Blackouts are disabled by default.

Lamp settings

Lamp on/off

To manually power the lamp on or off:

1. Select LAMP SETTINGS and press ENTER to confirm.
2. Use the DOWN and UP buttons to scroll to ON/OFF and press ENTER to confirm.
3. Use the DOWN and UP buttons to select ON or OFF.
4. Press ENTER to confirm and power the lamp on or off (or to return to the previous level of the menu structure without making a change, press MENU).

State/power on

To set the lamp to power on automatically when the fixture is powered on:

1. Select LAMP SETTINGS and press ENTER to confirm.
2. Use the DOWN and UP buttons to select STATE/POWER ON and press ENTER to confirm.
3. Use the DOWN and UP buttons to select ON or OFF.
4. Press ENTER to confirm (or to return to the previous menu level without making a change, press MENU).

DMX lamp control

The lamp can be controlled remotely by DMX. The following options are available:

- OFF VIA DMX allows the lamp to be powered off by sending a DMX command.
- ON IF DMX ON sets the lamp to power on automatically as soon as a DMX signal is present.
- OFF IF DMX OFF sets the lamp to power off automatically as soon as a DMX signal is not present

Ignition delay

If a large number of fixtures power their lamps on at the same time, voltage drops can result. To spread the load across multiple fixtures, an ignition delay of 0 to 255 seconds can be set, so that there is a delay between power on and lamp on.

1. Select LAMP SETTINGS and press ENTER to confirm.
2. Use the DOWN and UP buttons to select IGNITION DELAY and press ENTER to confirm.
3. Use the DOWN and UP buttons to specify a delay duration in seconds.
4. Press ENTER to confirm (or to return to the previous menu level without making a change, press MENU).

Low power delay

In a low-power delay, when a lamp off command is sent the lamp runs at half power for a period before powering completely off:

1. Select LAMP SETTINGS and press ENTER to confirm.
2. Use the DOWN and UP buttons to select LOW POWER DELAY and press ENTER to confirm.
3. Use the DOWN and UP buttons to specify a duration.
4. Press ENTER to confirm (or to return to the previous menu level without making a change, press MENU).

Display settings

Invert display

Inverting the display is useful if the fixture is hung from a truss or from elevation. To invert the display:

1. Select DISPLAY SETTINGS and press ENTER to confirm.

2. Use the DOWN and UP buttons to select DISPLAY INVERSE and press ENTER to confirm.
3. Use the DOWN and UP buttons to select the YES (invert).
4. Press ENTER to confirm (or to return to the previous menu level without making a change, press MENU).

Automatically turn off display backlight

The display backlighting remains on permanently by default when power is applied to the fixture. If you prefer, you can enable Sleep mode, where the backlighting goes off automatically when the buttons and menus have not been used for a short period:

1. Select DISPLAY SETTINGS and press ENTER to confirm.
2. Use the DOWN and UP buttons to select BACKLIGHT AUTO OFF and press ENTER to confirm.
3. Use the DOWN and UP buttons to select YES to enable automatic dimming.
4. Press ENTER to confirm (or to return to the previous menu level without making a change, press MENU).

Adjust backlight intensity

The brightness of the control panel display can be adjusted:

1. Select DISPLAY SETTINGS and press ENTER to confirm.
2. Use the DOWN and UP buttons to select BACKLIGHT INTENSITY and press ENTER to confirm.
3. Use the DOWN and UP buttons to set a level from 1 to 10.
4. Press ENTER to confirm (or to return to the previous menu level without making a change, press MENU).

Display panel contrast

To adjust the contrast of the control panel display to get the clearest readout:

1. Select DISPLAY SETTINGS and press ENTER to confirm.
2. Use the DOWN and UP buttons to adjust the intensity ratio from 1 (dark) to 30 (bright) and press ENTER to confirm.
3. Press MENU to return to the previous menu level or let the unit idle one minute to exit menu mode.

Temperature Celsius/Fahrenheit

To set temperatures to display in Celsius or Fahrenheit

1. Select TEMPERATURE UNIT and press ENTER to confirm.
2. Use DOWN and UP buttons to select ° C or ° F and press ENTER to store.
3. Press MENU to return to the previous menu level or let the unit idle one minute to exit menu mode.

Display warnings

To enable or disable error messages in the display if the fixture detects an error:

1. Select DISPLAY WARNING and press ENTER to confirm.
2. Use the DOWN and UP buttons to select YES or NO and press ENTER to confirm.
3. Press MENU to return to the previous menu level or let the unit idle one minute to exit menu mode.

Fixture tests

The fixture can carry out an automatic test of all functions, or individual functions can be tested manually.

Auto test

To perform a complete test of all of the effects:

1. Select FIXTURE TEST and press ENTER to confirm.
2. Use the DOWN and UP buttons to select AUTO TEST and press ENTER to confirm. The fixture will run an automatic test sequence of all the effects.

Manual test (manual control of individual effects)

To test individual effects:

1. Select FIXTURE TEST and press ENTER to confirm.
2. Use the DOWN and UP buttons to select MANUAL TEST and press ENTER to confirm.
3. Select the function you want to test and press ENTER to confirm. You can now test that function.
4. To return to the previous menu level, press MENU.

Fixture information

Fixture operating hours counter (non-resettable)

To see how many hours the fixture has been used since manufacture:

1. Select **FIXTURE INFORMATION** and press **ENTER** to confirm.
2. Use the **DOWN** and **UP** buttons to select **FIXTURE USE TIME** and press **ENTER** to confirm. The number of hours will be shown.

Lamp operating hours counter (resettable)

This counter can be reset. It can be used to monitor the number of lamp operating hours and help you decide when a lamp change is required.

1. Select **FIXTURE INFORMATION** and press **ENTER** to confirm.
2. Use the **DOWN** and **UP** buttons to select **LAMP ON TIME** and press **ENTER** to confirm. The fixture will display the number of hours the lamp has been on since the counter was last reset.
3. Use the **DOWN** and **UP** buttons to select **EXIT** to leave the lamp hours menu or **RESET TIME** to reset the lamp hours counter to zero. Press **ENTER** to confirm.

Firmware version

To see which software version is installed in the fixture:

1. Select **FIXTURE INFORMATION** and press **ENTER** to confirm.
2. Use the **DOWN** and **UP** buttons to select **FIRMWARE VERSION** and press **ENTER** to confirm. The firmware version will be shown.

Reset functions or effects

Individual effects (pan, tilt color, gobos, focus, prism) or all the effects can be manually reset to their home positions:

1. Select **RESET FUNCTIONS** and press **ENTER** to confirm.
2. Use the **DOWN** and **UP** buttons to select the function or effect that is to be reset. Press the **ENTER** button.
3. Use the **DOWN** and **UP** buttons to select **YES** and press **ENTER** to confirm (or to return to the previous menu level without making a change, press **MENU**).

Special functions

Fixture maintenance

You can schedule fixture maintenance by setting an interval in hours until the next service must be carried out. You can then view the number of hours remaining until this interval has been reached:

1. Select FIXTURE MAINTENANCE and press ENTER to confirm.
2. Use the DOWN and UP buttons to select INTERVAL or REMAIN TIME.

Interval

1. Select INTERVAL and press ENTER to confirm. The currently set service interval time will show on the display.
2. If you want to change the service interval, use the DOWN and UP buttons to adjust it and press ENTER to confirm.
3. Press MENU to exit.

Remain Time

1. Select Remain Time and press ENTER to confirm. The remaining time will show on the display.
2. Press ENTER, then use the DOWN and UP buttons to select EXIT or RESET TIME. EXIT returns to the previous menu without changing the remaining time. RESET TIME restarts the timer countdown at the number of hours defined in INTERVAL.
3. Press ENTER to confirm or press MENU to exit.

Factory settings

The fixture's factory default settings can be restored using FACTORY SETTINGS.

Effect home position (offset) adjustment

The fixture's effects (pan, tilt, shutter, color, gobo, prism, rotating prism and focus) can lose their home position if the fixture is exposed to shocks, for example. To adjust the effect's home position:

1. In the menu structure, press ENTER and hold for at least 3 seconds to enter the OFFSET MENU.
2. Use the DOWN and UP buttons to choose the effect that needs to be adjusted. Press ENTER to select it.
3. The effect's currently indexed home position will flash in the display. Use the DOWN and UP buttons to adjust it.

4. Once the correct position has been reached, press ENTER to set this (or to return to the previous menu level without making a change, press MENU).

Effects

This section describes DMX-controllable effects that require particular explanation. See 'DMX protocol' on page 32 for a full list of the DMX channels and values required to control the different effects.

Lamp control

For maximum lamp operating life:

- Avoid powering the lamp off until it has warmed up for at least 5 minutes.
- Before shutting down power completely, douse the lamp but leave power applied for a few minutes so that cooling fans can prevent any momentary lamp temperature increase caused by heat from surrounding components.

The fixture can be set to automatically turn the lamp on or off depending on whether or not a DMX signal is present.

The fixture can also be set to respond to or ignore lamp off commands sent via DMX.

An ignition delay of 0 to 255 seconds can be set, so that there is a delay between power on and lamp on.

A low-power delay of 0 to 255 seconds can be set, so that when a lamp off command is sent the lamp runs at half power for a user-defined period before shutting down.

For more information, see 'Lamp settings' on page 18.

Pan and tilt

The fixture's moving head can be panned through 540° and tilted through 270° using coarse or fine control channels. The fixture can be set to automatically blackout during pan and tilt movement.

The fixture incorporates pan and tilt feedback, so that if a pan or tilt position error is detected, the shutter closes and the fixture resets to the correct position. This can be enabled or disabled as required (see 'Control menus' on page 37).

Dimming

Full range mechanical dimming is provided.

Strobe effects

A range of variable strobe and pulse effects are available, with variable speed and random effects.

Gobos

The fixture contains a rotating wheel with 17 fixed gobos plus open (white):

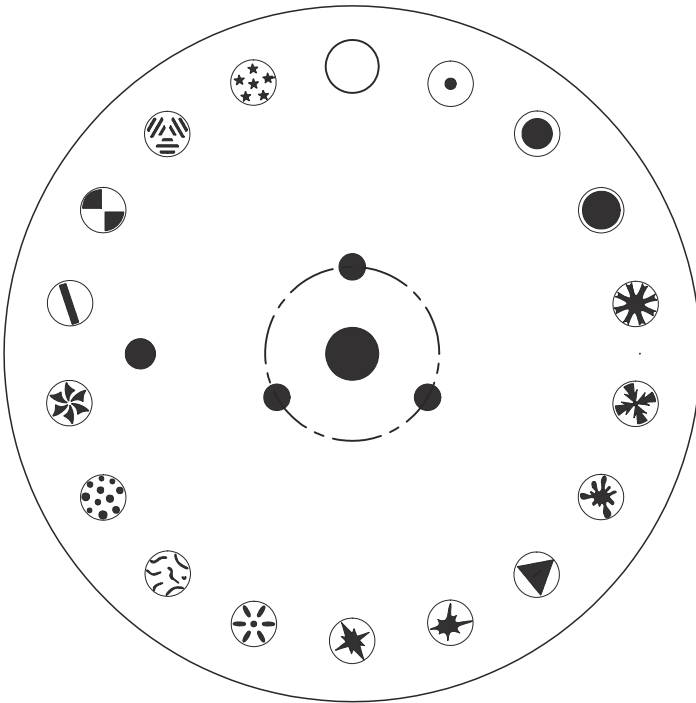

Open



Gobo 1



Gobo 2



Gobo 3



Gobo 4



Gobo 5



Gobo 6



Gobo 7



Gobo 8



Gobo 9



Gobo 10



Gobo 11



Gobo 12



Gobo 13



Gobo 14



Gobo 15



Gobo 16



Gobo 17

Any gobo can be projected, with split gobos also possible, or the wheel can be rotated clockwise or counter-clockwise at variable speeds. The sharpness of gobo projections can be adjusted using the Focus adjustment DMX channel.

Prism

The fixture incorporates a 6-facet prism that can be inserted into the beam to provide split effects. The prism can be set to an indexed position or rotated clockwise or counter-clockwise.

Color wheel

The fixture incorporates a single color wheel with 14 color filters plus open. The colors can be individually selected, split colors are available, and the wheel can be rotated at varying speeds clockwise and counter-clockwise.

The filters installed as standard in the color wheel are as follows:

Open			
Slot 1	Red	Slot 8	Light yellow
Slot 2	Amber	Slot 9	Magenta
Slot 3	Blue	Slot 10	Deep blue
Slot 4	Green	Slot 11	Yellow
Slot 5	Light green	Slot 12	CTO
Slot 6	Lavender	Slot 13	CTB
Slot 7	Pink	Slot 14	Violet

Maintenance



Read ‘Safety information’ on page 4 before servicing the fixture.

Refer any service or repair operation not described in this manual to an authorized Martin™ service technician.

Disconnect mains power before cleaning or servicing the fixture.

Service the fixtures in an area where there is no risk of injury from falling parts, tools or other materials.

Installation, on-site service and maintenance can be provided worldwide by the Martin Professional Global Service organization and its approved agents, giving owners access to Martin’s expertise and product knowledge in a partnership that will ensure the highest level of performance throughout the product’s lifetime. Please contact your RUSH by Martin™ supplier for details.

Cleaning

Excessive dust, smoke fluid, and particle buildup degrades performance, causes overheating and will damage the fixture. Damage caused by inadequate cleaning or maintenance is not covered by the product warranty.

The cleaning of external optical lenses must be carried out periodically to optimize light output. Cleaning schedules for lighting fixtures vary greatly depending on the operating environment. It is therefore impossible to specify precise cleaning intervals for the fixture. Environmental factors that may result in a need for frequent cleaning include:

- Use of smoke or fog machines.
- High airflow rates (near air conditioning vents, for example).
- Presence of cigarette smoke.
- Airborne dust (from stage effects, building structures and fittings or the natural environment at outdoor events, for example).

If one or more of these factors is present, inspect fixtures within their first 100 hours of operation to see whether cleaning is necessary. Check again at frequent intervals. This procedure will allow you to assess cleaning requirements in your particular situation. If in doubt, consult your RUSH by Martin dealer about a suitable maintenance schedule.

Use gentle pressure only when cleaning, and work in a clean, well-lit area. Do not use any product that contains solvents or abrasives, as these can cause surface damage.

To clean the fixture:

1. Disconnect the fixture from power and allow it to cool for at least 60 minutes.
2. Vacuum or gently blow away dust and loose particles from the outside of the fixture and the air vents at the back and sides of the head and in the base with low-pressure compressed air.
3. Clean optical components by wiping gently with a soft, clean lint-free cloth moistened with a weak detergent solution. Do not rub the surface hard: lift particles off with a soft repeated press. Dry with a soft, clean, lint-free cloth or low-pressure compressed air. Remove stuck particles with an unscented tissue or cotton swab moistened with glass cleaner or distilled water.
4. Check that the fixture is dry before reapplying power.

Replacing the lamp



Read ‘Lamp safety’ on page 7 before servicing the lamp.

To avoid the risk of a discharge lamp exploding in the fixture, always replace the lamp before its expected lifespan has been exceeded.

The lamp must be perfectly clean. Do not touch the lamp’s glass bulb with bare hands. If this happens, clean the lamp with an alcohol wipe and dry it with a clean, lint-free cloth.

To replace the lamp:

1. If the fixture has been in use, power the lamp off but leave the fixture powered on for at least 10 minutes so that the cooling fans cool the lamp. Disconnect the fixture from power and allow it to cool for 60 minutes.

2. See illustration on right. Loosen the screws in the top head cover (arrowed) using a Phillips screwdriver and remove the cover. Loosen the corresponding screws in the bottom head cover and remove that cover also.

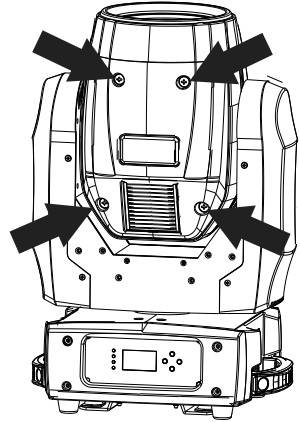

3. Lift the lamp out of its recess.

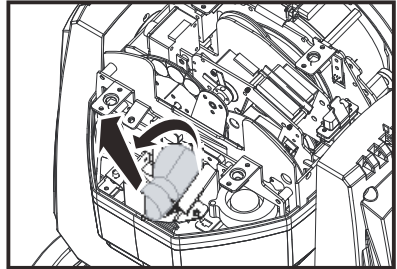

4. Disconnect the lamp and connect a new lamp that is approved by Martin for this product.

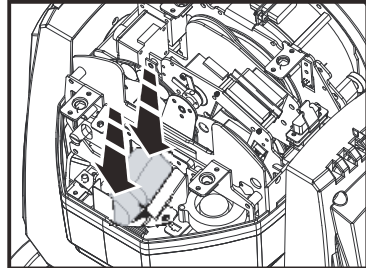
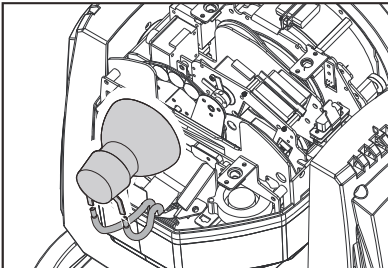

5. Place the new lamp into the lamp recess.

6. See illustration on right. The lamp can be adjusted using a flat-bladed screwdriver. Center the lamp for the best projection.
7. Reinstall the head covers, fastening them securely, before reapplying power.
8. Reset the Lamp On Time counter in the control menus.

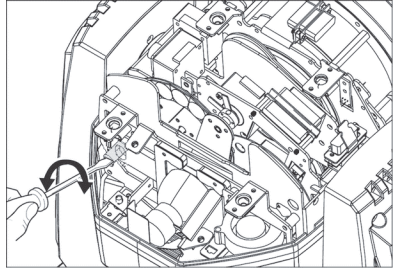

Fuse replacement

If the fixture is completely dead, the fixture's primary fuse F1 may have blown and it may be necessary to install a new fuse. This fuse is located in a fuseholder next to the Mains OUT socket on the connections panel. See 7 in 'Fixture overview' on page 14.

To change the fuse:

1. Disconnect the fixture from power and allow it to cool for at least 60 minutes.
2. Use a large flat-bladed screwdriver to unscrew the cap of the fuseholder.
3. Replace the fuse with one of the same type and rating only.
4. Reinstall the fuseholder cap before reapplying power.

DMX protocol

Channel	Value	Function	Fade type	De- fault
1	0-255	Dimming coarse 0→100%	Fade	0
2	0-255	Dimming fine	Fade	0
3	0-7 8-15 16-131 132-167 168-203 204-239 240-247 248-255	Shutter Closed Open Shutter strobe effect, slow → fast Fast close, slow open Slow close, fast open Pulse open and close Shutter strobe effect, random strobe Open	Snap	12
4	0 1-10 11 12-21 22 23-32 33 34-43 44 45-54 55 56-65 66 67-76 77 78-87 88 89-98 99 100-109 110 111-120	Color wheel: continuous scrolling Open Open → Red Red Red → Amber Amber Amber → Blue Blue Blue → Green Green Green → Light green Light green Light green → Lavender Lavender Lavender → Pink Pink Pink → Light yellow Light yellow Light yellow → Magenta Magenta Magenta → Deep blue Deep blue Deep blue → Yellow	Snap	0

Channel	Value	Function	Fade type	De- fault
	121	Yellow		
	122-131	Yellow → CTO		
	132	CTO		
	133-142	CTO → CTB		
	143	CTB		
	144-153	CTB → Violet		
	154	Violet		
	155-159	Violet → Open		
	160	Open		
		Color wheel: stepped scrolling		
	161-162	Red		
	163-164	Amber		
	165-166	Blue		
	167-167	Green		
	169-170	Light green		
	171-172	Lavender		
	173-174	Pink		
	175-176	Light yellow		
	177-178	Magenta		
	179-180	Deep blue		
	181-182	Yellow		
	183-184	CTO		
	185-186	CTB		
	187-188	Violet		
	189-192	Open		
		Color wheel: continuous rotation		
	193-214	Clockwise rotation fast →slow		
	215-221	Stop (wheel stops at current position)		
	222-243	Counter-clockwise rotation slow → fast		
		Color wheel: random slots		
	244-247	Random color, fast		
	248-251	Random color, medium		
	252-255	Random color, slow		
5		Gobo wheel: continuous scrolling	Snap	0
	0	Open		
	1-8	Open → Gobo 1		
	9	Gobo 1		
	10-17	Gobo 1 → Gobo 2		
	18	Gobo 2		

Channel	Value	Function	Fade type	De-fault
	19-26	Gobo 2 → Gobo 3		
	27	Gobo 3		
	28-35	Gobo 3 → Gobo 4		
	36	Gobo 4		
	37-44	Gobo 4 → Gobo 5		
	45	Gobo 5		
	46-53	Gobo 5 → Gobo 6		
	54	Gobo 6		
	55-62	Gobo 6 → Gobo 7		
	63	Gobo 7		
	64-71	Gobo 7 → Gobo 8		
	72	Gobo 8		
	73-80	Gobo 8 → Gobo 9		
	81	Gobo 9		
	82-89	Gobo 9 → Gobo 10		
	90	Gobo 10		
	91-98	Gobo 10 → Gobo 11		
	99	Gobo 11		
	100-107	Gobo 11 → Gobo 12		
	108	Gobo 12		
	109-116	Gobo 12 → Gobo 13		
	117	Gobo 13		
	118-125	Gobo 13 → Gobo 14		
	126	Gobo 14		
	127-134	Gobo 14 → Gobo 15		
	135	Gobo 15		
	136-143	Gobo 15 → Gobo 16		
	144	Gobo 16		
	145-152	Gobo 16 → Gobo 17		
	153	Gobo 17		
	154-156	Gobo 17 → Open		
		Gobo wheel: stepped scrolling		
	157-158	Gobo 1		
	159-160	Gobo 2		
	161-162	Gobo 3		
	163-164	Gobo 4		
	165-166	Gobo 5		
	167-168	Gobo 6		
	169-170	Gobo 7		

Channel	Value	Function	Fade type	De-fault
	171-172 173-174 175-176 177-178 179-180 181-182 183-184 185-186 187-188 189-190 191-192 193-214 215-221 222-243 244-247 248-251 252-255	Gobo 8 Gobo 9 Gobo 10 Gobo 11 Gobo 12 Gobo 13 Gobo 14 Gobo 15 Gobo 16 Gobo 17 Open Gobo wheel: continuous rotation Clockwise rotation fast → slow Stop (wheel stops at current position) CCW rotation slow → fast Gobo wheel: random gobos Random gobo, fast Random gobo, medium Random gobo, slow		
6	0-10 11-138 139-255	Prism Open Prism indexing (control on next channel) Prism rotation (control on next channel)	Snap	0
7	0-255 0-2 3-126 127-129 130-253 254-255	Prism Indexing control Indexed position (128 = prism indexed at 0°) Prism Rotation control No rotation (prism indexed at 0°) Rotation CW fast → CW Slow No rotation (prism stops at current position) Rotation CCW Slow → CCW Fast No rotation (prism indexed at 45°)	Fade	128
8	0-255	Focus Infinity → Near	Fade	128
9	0-255	Pan coarse 0° → 540°	Fade	128
10	0-255	Pan fine	Fade	0

Channel	Value	Function	Fade type	De-fault
11	0-255	Tilt coarse 0° → 270°	Fade	128
12	0-255	Tilt fine	Fade	0
13		Fixture control	Snap	0
	0-9	No function (disables calibration)		
	10-14	Reset fixture		
	15-19	Reset dimmer/shutter		
	20-24	Reset color		
	25-29	Reset gobos		
	30-34	Reset pan and tilt		
	35-39	Reset focus		
	40-44	Lamp on		
	45-49	Lamp off		
	50-54	<i>No function</i>		
	55-59	Enable calibration		
	60-79	<i>No function</i>		
	80-84	Pan & tilt speed = Normal		
	85-89	Pan & tilt speed = Fast (default)		
	90-94	Pan & tilt speed = Slow		
	95-99	Effect shortcuts = On (default)		
	100-104	Effect shortcuts = Off		
	105-144	<i>No function</i>		
	145-149	Auto-blackout = On		
	150-154	Auto-blackout = Off (default)		
	155-159	Illuminate control panel display		
	160-164	Turn off control panel display		
	165-209	<i>No function</i>		
	210-214	Store dimmer calibration		
	215-219	Store gobo wheel calibration		
	220-224	Store focus calibration		
	225-229	Store color wheel calibration		
	230-234	Store prism calibration		
	235-239	Store pan calibration		
	240-244	Store tilt calibration		
	245-249	Reset all calibration values to factory defaults		
	250-255	<i>No function</i>		

Control menus

To access the control menus, press the MENU button. Use the UP and DOWN buttons to navigate the menus. Select any required menu option using the ENTER button. For more information, see ‘Using the control panel’ on page 16.

Default fixture settings are shown in **bold**.

Menu	Sub-menu	Setting/ value	Explanation
DMX Functions	DMX Address	1-512	Set fixture’s DMX address
	DMX Channel Mode		<i>Reserved for future use</i>
	View DMX Value		View DMX values received
Fixture setting	Pan Inverse	No	Invert pan movement (map left to right)
		Yes	
	Tilt Inverse	No	Invert tilt movement (map up to down)
		Yes	
	P/T Feedback	No	No pan or tilt position error correction
		Yes	If a pan or tilt position error is detected, the fixture corrects pan/tilt position
	Bi.O. P/T Moving	No	Blackout during pan or tilt movement
		Yes	
	Bi.O. Color Change	No	Blackout during color change
		Yes	
	Bi.O. Gobo Change	No	Blackout during gobo change
		Yes	

Lamp Setting	On/Off	Off	Manually power lamp on or off
		On	
	State/Power On	Off	Lamp powers on automatically when fixture is powered on
		On	
	Off via DMX	No	Lamp can be powered off via DMX
		Yes	
	On if DMX On	No	Lamp powers on if DMX signal received
Yes			
Off if DMX Off	No	Lamp powers off if DMX signal not received	
	Yes		
Ignition Delay	0-255S	Delay lamp ignition (0 to 255 seconds).	
Low Power Delay	0-255S	Half-power period before powering lamp off completely (0 to 255 seconds)	
Display settings	Display inverse	No	Invert control panel display
		Yes	
	Backlight Auto Off	No	Automatically turn off display panel backlight when not in use.
		Yes	
	Backlight Intensity	1-10	Set display panel backlight intensity
	Contrast	1-30	Set display panel contrast
Temperature Unit	°C	Temperature display Celsius/Fahrenheit	
	°F		
Display Warning	No	Show service warnings in display panel	
	Yes		
Fixture Test	Auto Test		Automatic test of all functions
	Manual Test		Manual test of each function

Fixture Information	Fixture Use Time		Total operating hours since manufacture
	Lamp On Time	Exit	
		Reset Time	Reset lamp hour use counter
Firmware Version		Currently installed firmware version	
Reset Functions	Pan/Tilt	No	Reset pan and tilt
		Yes	
	Shutter/Dimmer	No	Reset shutter/dimmer
		Yes	
	Color	No	Reset color wheel
		Yes	
	Gobo	No	Reset gobo wheel
		Yes	
	Focus	No	Reset focus
		Yes	
	All	No	Reset all effects
		Yes	
Special Functions	Fixture Maintenance	Interval	Set new maintenance countdown timer period
		Remain time	View maintenance countdown timer
	Factory Settings	No	Return fixture to factory default settings
		Yes	

Offset menu

The offset menu is used to adjust the home position of the various effects.

To access the Offset menu, press the MENU button to enter the menu structure and then press and hold ENTER for three seconds.

Menu	Sub-menu	Setting	Explanation
Offset Menu	Pan	-128→127	Pan offset
	Tilt	-128→127	Tilt offset
	Shutter	0→255	Shutter offset
	Color	-128→127	Color offset
	Gobo	-128→127	Gobo offset
	Prism	0→255	Prism offset
	R-Prism	-128→127	Rotating prism offset
	Focus	0→255	Focus offset

Error messages

Error:	Appears when:
Lamp Startup Fail	No lamp detected or wiring fault.
Temperature Sense Error	Temperature sensor on the PCB is damaged. Contact your RUSH by Martin authorized distributor for assistance.
Lamp Too Hot Low Power	Temperature higher than 105° C detected. The fixture runs at a low power level.
Lamp Too Hot Power Off	Temperature higher than 110° C detected. Check that ambient temperature does not exceed 40° C. Check that fixture is adequately ventilated. The fans or temperature sensor might be damaged. Contact your RUSH by Martin authorized distributor for assistance.
Maintenance Fixture	Service countdown timer has reached zero. Service the fixture, then reset the countdown timer in the control menu.
Lamp On Over 2000 Hour	The lamp has had more than 2000 hours of use. Change the lamp as directed in this manual. Continuing to use the lamp increases the risk of a lamp explosion.
Memory Initial Fail	Damaged memory IC. Contact your RUSH by Martin authorized distributor for assistance.
CPU-B Error CPU-C Error CPU-D Error	CPU, PCB or fixture wiring is damaged. Contact your RUSH by Martin authorized distributor for assistance.
Pan Reset Error Pan Encode Error Tilt Reset Error Tilt Encode Error Shutter Reset Fail Dimmer Reset Fail Color Reset Fail Gobo Reset Fail Focus Reset Fail	These can appear when powering on or resetting the fixture and can indicate damage to sensors or components. Contact your RUSH by Martin authorized distributor for assistance.

Troubleshooting

This section describes a few common problems that may occur during operation and provides some suggestions for easy troubleshooting:

Symptom	Potential cause	Remedies
No light from fixture, or fans not working.	Power supply issue, such as blown fuse, faulty connector or damaged cable.	<p>Check that mains supply is connected and supplying power to the fixture.</p> <p>Check that fixture's Power indicator LED is lit.</p> <p>Check all power connections and cables.</p> <p>Replace fixture's primary fuse.</p>
One of the control channels is unresponsive or only responds intermittently.	Damaged step motor or cable connection between the head and body.	Contact your RUSH by Martin™ authorized distributor for assistance.
Lamp cuts out intermittently	Incorrect mains voltage or the internal temperature is too high.	<p>Check mains voltage.</p> <p>Fan may need replacing. Contact your RUSH by Martin™ authorized distributor for assistance.</p>
Fixture does not respond to DMX control.	<p>Incorrect DMX addressing.</p> <p>Fault on DMX link due to damaged connector or cable, or potential interference from proximity to a high-voltage installation.</p>	<p>Ensure that fixture's DMX address matches address set on DMX control device.</p> <p>Check that fixture's DMX indicator LED is on, and if not, check all DMX cables and connections.</p> <p>Check that DMX link is terminated.</p>

Symptom	Potential cause	Remedies
		<p>Check that all devices on DMX link use standard DMX polarity.</p> <p>Attempt to control the fixture with another DMX control device.</p> <p>Move or shield link if it is very close to an unshielded high-voltage installation.</p>

Specifications

Physical

Weight 14 kg (30.9 lbs.)
Dimensions (W x H x D) 319 x 256 x 481 mm (12.6 x 10.1 x 18.9 in.)

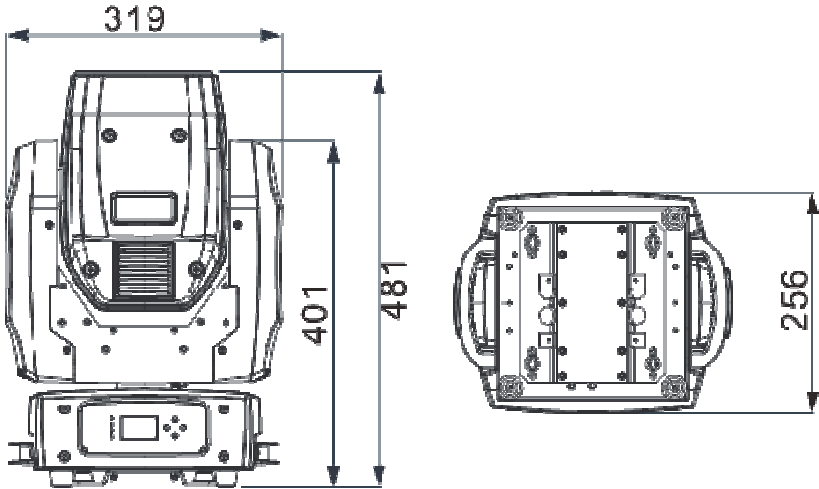

Lamp

Approved lamp Philips MSD Platinum 2R
Color temperature 9000 K
CRI (Color rendering index) 75
Average lifetime 2000 hours

Dynamic Effects

Color wheel 14 colors plus open, continuous and stepped scrolling, rotation with variable direction and speed
Static gobo wheel . 17 gobos plus open, continuous and stepped scrolling, rotation with variable direction and speed
Shutter Strobe effects, pulse effects, instant open and blackout
Prism 6-facet, indexing and rotation with variable direction and speed
Focus Motorized
Dimmer 0 - 100% continuous dimming
Pan 540°
Tilt 270°

Control and Programming

Control system	DMX
DMX channels	13
Setting and addressing.....	Control panel with backlit LCD display
DMX compliance	USITT DMX512/1990
16-bit control.....	Dimming, pan, tilt
Pan and tilt speed.....	Adjustable via onboard control panel and DMX
Position correction system	Pan and tilt

Optics

Beam angle	3°
------------------	----

Construction

Color.....	Black
Housing	High-impact flame-retardant thermoplastic
Protection rating	IP 20

Installation

Mounting points	Four quarter-turn bracket mounting points
Minimum distance from illuminated surfaces	6.5 m (21.3 ft.)
Location.....	Indoor use only, must be fastened to surface or structure
Orientation.....	Any

Connections

AC power in/out.....	Neutrik PowerCon
DMX data in/out.....	3-pin & 5-pin locking XLR

Electrical

AC power.....	100-240 V nominal, 50/60 Hz
Fuse.....	T6.3A
Power supply unit.....	Auto-ranging electronic switch-mode

Typical power and current

110 V, 60 Hz.....	2.2 A, 234 W, PF 0.996
230 V, 50 Hz.....	1.1 A, 231 W, PF 0.996

Measurements made at nominal voltage. Figures are typical, not maximum. Allow for a deviation of +/- 10%.

Thermal

Cooling	Forced air
Maximum ambient temperature (T _a max.).....	40° C (104° F)
Minimum ambient temperature (T _a min).....	0° C (32° F)
Total heat dissipation (calculated, +/- 10%).....	800 BTU/hr.

Approvals



EU safety	EN 60598-2-17 (EN 60598-1), EN 62471, EN 62493
EU EMC.....	EN 55015, EN 55103-1, EN 55103-2, EN 61000-3-2, EN 61000-3-3, EN 61547
US safety (pending).....	UL 1573
US EMC.....	FCC Part 15 Class A
Canadian safety (pending)	CSA C22.2 No. 166
Canadian EMC	ICES-003 Class A
Australia/NZ.....	C-TICK N4241

Included Items

- Power cable, 6 A, 18 AWG, 0.75 mm², UL- listed, H05VV-F, 1.5 m, without mains plug
- Two omega-type brackets for rigging clamp attachment

Accessories

Cables, 16 A, for connection to power in chains

- Power input cable, 14 AWG, SJT, 1.5 mm², H05VV-F, with PowerCon input connector, 3 m (9.8 ft.)..... P/N 11541508
- Power relay cable, 14 AWG, SJT, 1.5 mm², H05VV-F, with PowerCon connectors, 1.4 m (4.6 ft.)..... P/N 11541509
- Power relay cable, 14 AWG, SJT, 1.5 mm², H05VV-F, with PowerCon connectors, 2.25 m (7.4 ft.)..... P/N 11541510
- Power relay cable, 14 AWG, SJT, 1.5 mm², H05VV-F, with PowerCon connectors, 3.25 m (10.7 ft.)..... P/N 11541511

Power connectors

- Neutrik PowerCon NAC3FCA
power input connector, cable mount, blue P/N 05342804
- Neutrik PowerCon NAC3FCB
power output connector, cable mount, light grey P/N 05342805

Installation hardware

- Half-coupler clamp P/N 91602005
- G-clamp (suspension vertically downwards only) P/N 91602003
- Quick-trigger clamp (suspension vertically downwards only)P/N 91602007
- Safety cable, safe working load 50 kg..... P/N 91604003

Related Items

RUSH Software Uploader 1™ P/N 91611399

Ordering Information

RUSH MH 4 Beam™ in cardboard box..... P/N 90280030

Specifications are subject to change without notice. For latest product specifications, see www.martin.com



Disposing of this product

RUSH by Martin™ products are supplied in compliance with Directive 2012/19/EC of the European Parliament and of the Council of the European Union on WEEE (Waste Electrical and Electronic Equipment), where applicable. Help preserve the environment! Ensure that this product is recycled at the end of its life. Your supplier can give details of local arrangements for the disposal of RUSH by Martin™ products

Photobiological Safety Warning

RISK GROUP 2

WARNING! IR emitted from this product. Do not stare at operating lamp. May be harmful to the eyes.

CAUTION! UV emitted from this product. Minimize exposure to eyes or skin. Use appropriate shielding or eye protection.

The label shown above is displayed on this product. If it becomes difficult or impossible to read, it must be replaced using the above illustration to reproduce a new label with a yellow background.



Innovation • Quality • Performance