

Exterior Wash™ 200 Series

User manual



© 2015-2016 Martin Professional™ ApS. Information subject to change without notice. Martin Professional™ and all affiliated companies disclaim liability for any injury, damage, direct or indirect loss, consequential or economic loss or any other loss occasioned by the use of, inability to use or reliance on the information contained in this manual. Martin™, Harman™ and all other trademarks in this document pertaining to services or products by Martin Professional™ or its affiliates and subsidiaries are registered as the property of Harman International Industries.

P/N 5068004, Rev. E

Table of contents

Safety information	5
Introduction	9
Fixture overview	9
Before using the product for the first time	9
Physical installation.....	10
Fixture location	10
Mounting the fixture	10
Adjusting tilt	11
Installing a diffuser	11
Installing a snoot	12
AC power	13
Connecting to power.....	13
Control data link	15
Connecting the data link	15
Setup.....	16
Accessing and navigating the control menus	16
DMX settings	16
Programming a standalone show	17
Manual mode.....	17
Display setting	17
Automatic test.....	18
Fixture status.....	18
Fixture config.....	18
Setup via RDM	20
Maintenance	21
Cleaning	21
Pressure relief valve.....	21
DMX protocol	22
Exterior Wash 200 and Exterior Wash 210	22
Exterior Wash 220.....	22
Control menus.....	23
Troubleshooting	25
Specifications	26

Safety information



WARNING!

Read the safety precautions in this manual before installing, operating or servicing this product.

The following symbols are used to identify important safety information on the product and in this manual:



Warning! Safety hazard. Risk of severe injury or death.



Warning! Hot surface. Risk of burns.



Warning! See user manual for important safety information.



Warning! Risk of eye injury. Wear protective eyewear.



Warning! Hazardous voltage. Risk of lethal or severe electric shock.



Warning! Do not look into light output.



Warning! Fire hazard.



Warning! Risk Group 3 product according to EN 62471. Do not look directly into the beam. Do not view the light output with optical instruments or any device that may concentrate the beam.

This lighting fixture is for professional use only and must be installed by a qualified technician. It is not for household use. It presents risks of severe injury or death due to fire hazards, electric shock and falls. It produces a powerful, concentrated beam of light that can create a fire hazard or a risk of eye injury if the safety precautions below are not followed.



Install, operate and service Martin™ products only as directed in their user manuals, or you may create a safety hazard or cause damage that is not covered by product warranties. Follow the safety precautions listed below and observe all warnings in this manual and printed on the product. Keep this user manual for future use.

For the latest user documentation and other information about this and all Martin™ products, please visit the Martin website at <http://www.martin.com>

If you have any questions about how to install, operate or service the fixture safely, please contact your Martin™ distributor (see www.martin.com/distributors for details) or call the Martin™ 24-hour service hotline on +45 8740 0000, or in the USA on 1-888-tech-180.

Respect all locally applicable laws, codes and regulations when installing, operating or servicing the fixture.



Protection from electric shock

Ensure that the fixture is electrically connected to ground (earth).

Disconnect the fixture from AC power when not in use.

Supply the fixture with AC power only at the voltages specified in this user manual and on the product's serial number label.

Do not open the fixture or remove any cover. Refer any service operation not described in this manual to an authorized Martin Service partner.

Shut down power to the entire installation at the main power distribution board and lock out power before carrying out any installation or maintenance work.

Use only a source of AC power that complies with local building and electrical codes and has both overload and ground-fault (earth-fault) protection.

Isolate the fixture from power immediately if any seal, cover, cable, or other component is damaged, defective, deformed or showing signs of overheating. Do not reapply power until repairs have been completed

Before using the fixture, check that all power distribution equipment and cables are in perfect condition, are rated for the current requirements of all connected devices, are protected to IP67 or higher and are of suitable type for the location (including water, pollution, temperature and UV resistance).

Do not immerse the fixture in water or any other fluid, or install it in a location where flooding may occur.



Protection from burns and fire

Do not operate the fixture if the ambient temperature (T_a) exceeds 45°C (113°F).

The surface of the product can reach up to 55°C (131°F) during operation. Avoid contact by persons and materials. Allow the fixture to cool for at least 10 minutes before handling.



Keep flammable materials well away from the fixture. Keep all combustible materials (e.g. fabric, wood, paper) at least 10 cm (4 in.) away from the fixture.

Ensure that there is free and unobstructed airflow around the fixture.

Do not illuminate surfaces within 20 cm (8 in.) of the fixture.

Do not attempt to bypass thermostatic switches or fuses.

Do not modify the fixture in any way not described in this manual or install other than genuine Martin™ parts. Do not stick filters, masks or other materials onto any lens or other optical component. Use only accessories approved by Martin™ to modify the light beam.



Protection from eye injury

The Exterior Wash 200, 210 and 220 are classed Risk Group 3 according to EN 62471.

Possibly hazardous radiation emitted from this product. Do not look at operating lamp. Eye injury may result.



To minimize the risk of eye irritation or injury, disconnect the fixture from power at all times when the fixture is not in use, and provide well-lit conditions to reduce the pupil diameter of anyone working on or near the fixture.

Do not look at the light output with magnifiers, telescopes, binoculars or similar optical instruments that may concentrate the output.

Ensure that persons are not looking directly into the fixture when it lights up suddenly. This can happen when power is applied, when the fixture receives a DMX signal, or when certain control menu items are selected.

Wear protective glasses and other PPE (personal protective equipment) when working on or near the fixture.

The risk group distances given below apply to the light output from one fixture only. If fixtures can be operated in combination, light intensity can increase and you should consult a lighting professional for safety recommendations.

Exterior Wash 200

The Exterior Wash 200 falls into the following risk groups according to EN 62471 at the distances indicated:

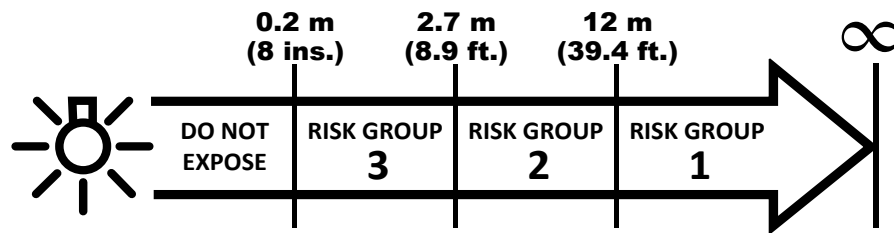

At a distance of less than 2.7 m (8.9 ft.) from the fixture, the light output can potentially cause eye or skin injury before an exposed person's natural aversion responses (blink reflex and reaction to skin discomfort) can protect them. At distances greater than 2.7 m (8.9 ft.), potential eye and skin injury hazards from the light output are normally prevented by natural aversion reflexes.

Position the Exterior Wash 200 so that persons cannot be exposed to the fixture's light output at less than 2.7 m (8.9 ft.) from the fixture and so that prolonged staring into the light output at less than 12 m (39.4 ft.) from the fixture is not expected.

Exterior Wash 210

The Exterior Wash 210 falls into the following risk groups according to EN 62471 at the distances indicated:

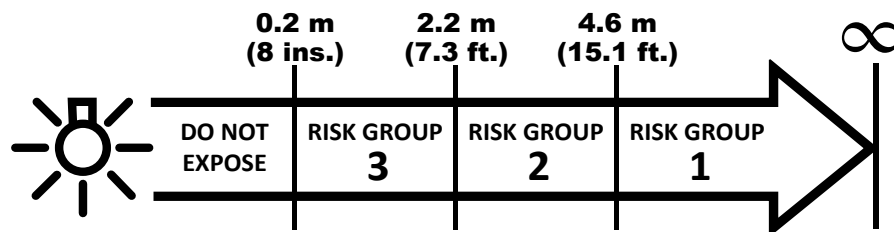

At a distance of less than 2.2 m (7.3 ft.) from the fixture, the light output can potentially cause eye or skin injury before an exposed person's natural aversion responses (blink reflex and reaction to skin discomfort) can protect them. At distances greater than 2.2 m (7.3 ft.), potential eye and skin injury hazards from the light output are normally prevented by natural aversion reflexes.

Position the Exterior Wash 210 so that persons cannot be exposed to the fixture's light output at less than 2.2 m (7.3 ft.) from the fixture and so that prolonged staring into the light output at less than 4.6 m (15.1 ft.) from the fixture is not expected.

Exterior Wash 220

The Exterior Wash 220 falls into the following risk groups according to EN 62471 at the distances indicated:

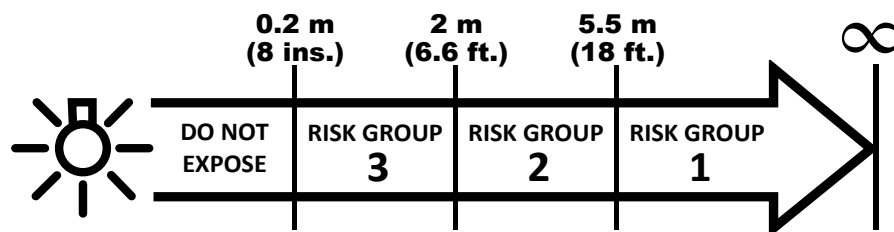

At a distance of less than 2 m (6.6 ft.) from the fixture, the light output can potentially cause eye or skin injury before an exposed person's natural aversion responses (blink reflex and reaction to skin discomfort) can protect them. At distances greater than 2 m (6.6 ft.), potential eye and skin injury hazards from the light output are normally prevented by natural aversion reflexes.

Position the Exterior Wash 220 so that persons cannot be exposed to the fixture's light

output at less than 2 m (6.6 ft.) from the fixture and so that prolonged staring into the light output at less than 5.5 m (18 ft.) from the fixture is not expected.



Protection from injury

Fasten the fixture securely to a fixed surface or structure when in use. The fixture is not portable when installed.

Ensure that any supporting structure and/or hardware used can hold at least 10 times the weight of all the devices they support.

If suspending from a rigging structure, fasten the fixture to a rigging clamp. Do not use safety cables as the primary means of support. If the fixture is installed in a location where it may cause injury or damage if it falls, provide a secondary attachment such as a safety cable inserted through the secondary attachment point that will hold the fixture if a primary attachment fails. The secondary attachment must be approved by an official body such as TÜV as a safety attachment for the weight that it secures, must comply with EN 60598-2-17 Section 17.6.6 and must be capable of bearing a static suspended load that is ten times the weight of the fixture and all installed accessories.

Verify that any optical accessory such as a snoot or diffuser lens is securely fastened.

Block access below the work area and work from a stable platform whenever installing, setting, adjusting, or cleaning the fixture.

Do not operate the fixture with missing or damaged covers, shields or any optical component.

In the event of an operating problem, stop using the fixture immediately and disconnect it from power. Do not attempt to use a fixture that is obviously damaged.

Introduction

The Exterior Wash™ 200 Series is a powerful, compact and energy-efficient line of LED lighting fixtures designed to illuminate mid-sized structures and building facades. All models have built-in displays for ease-of-use, a wide selection of beam angles and sealed construction suited to permanent outdoor use. A discreet, optional snoot integrates seamlessly with the fixtures' sleek design to put the light right where you want it.

This user manual covers all Exterior Wash™ 200 Series models: the Exterior Wash 200 with individual red, green, blue, and white LEDs optimized for long-throw applications, the Exterior Wash 210 with premixed quad-color LEDs optimized for superior color mixing, and the Exterior Wash 220 with mixable warm-white and cold-white LEDs that can achieve white tones ranging in color temperature from 2800 K to 6500 K.

Each fixture is supplied with this user manual and an optional control panel cover plate to deter unauthorized access. They are prepared for hard wiring with 1.8 m (5.9 ft.) cables for power and data connection.

Fixture overview

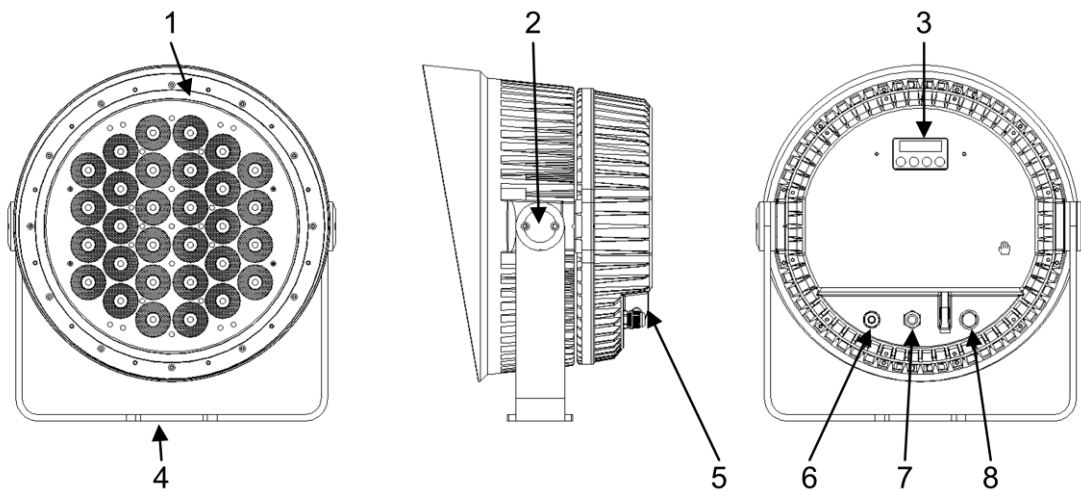

Number	Description
1	Front ring with recessed channel for optional diffuser lenses
2	Tilt lock (one on each side)
3	Control panel
4	Mounting bracket
5	Secondary attachment point
6	DMX combined input/output cable
7	AC power cable
8	Pressure relief valve

Parts identification

Before using the product for the first time

1. Read 'Safety information' on page 5 before installing, operating or servicing the fixture.
2. Unpack and ensure that there is no transportation damage before using the fixture. Do not attempt to operate a damaged fixture.
3. If testing and/or setting up the fixture before it is hard-wired to a mains supply, install a local power plug (not supplied) to the end of the supplied power cable.
4. Before operating, ensure that the voltage and frequency of the power supply match the power requirements of the fixture.
5. Check the support pages on the Martin Professional website at www.martin.com for the most recent user documentation and technical information about the fixture. Martin™ user manual revisions are identified by the revision letter at the bottom of the inside cover.

Physical installation



Warning! Read 'Safety information' on page 5 before installing the fixture.

Warning! The safety and suitability of lifting equipment, installation location, anchoring method, mounting hardware and electrical installation are the responsibility of the installer. All local safety regulations and legal requirements must be observed when installing and connecting the Exterior Wash™ 200 Series. Installation must be carried out by qualified professionals only.

Contact your Martin supplier for assistance if you have any questions about how to install this product safely.

Fixture location

Exterior Wash™ 200 Series fixtures are intended for outdoor use. With an IP rating of 66, they are dust tight and able to withstand powerful water jets, but they are not submersible.

Observe the following limitations in selecting a location:

- Do not immerse the fixture in water or any other fluid.
- Do not install fixtures in a location where flooding may occur.
- Do not allow water to collect on or near the pressure relief valve. Do not install a fixture with the valve membrane horizontal so that water can pool on it.
- Ensure sufficient drainage to cope with the heaviest rainfall. Make sure that water can drain away from the installation area at least as fast as it can enter it.
- Fixtures require free and unobstructed airflow around them to ensure adequate cooling: do not bury or locate in an unventilated space. Allow at least 0.1 m (4 in.) free space around the fixture.
- Install the fixture at least 0.2 m (8 in.) away from the surface to be illuminated and at least 0.1 m (4 in.) away from any combustible materials (wood, paper, etc.). Keep it well away from any flammable materials.
- The fixture can become hot. Restrict public access or locate the fixture so that it cannot accidentally be touched.

Mounting the fixture



Warning! All fasteners used to mount Exterior Wash™ 200 Series fixtures must be corrosion resistant and strong enough to mount the fixture safely.

A washer must be installed directly under the head of each fastener when anchoring the yoke base to the installation surface.

The fixture and mounting bracket are manufactured in corrosion-resistant anodized aluminum. Avoid mounting the fixture in direct contact with other types of metal, as this can cause galvanic corrosion. When fastening to a dissimilar metal surface:

- Use an electrically insulating material (such as rubber or plastic) or coating between the mounting bracket and the other metal.
- Use a non-conductive coating such as Delta Seal on fasteners (screws, bolts, washers, etc.) where they come into contact with the mounting bracket.

The fixture's mounting yoke base must be securely anchored to a wall, pedestal, structural beam or other suitable support. The yoke allows the fixture to be manually panned and tilted for beam aiming adjustment.

The fixture and base can be mounted at any angle. The mounting surface must be hard, fixed and flat.

For temporary installations, the fixture is also suitable for truss hanging with a rigging clamp securely fastened to the yoke base. When using a rigging clamp, secure the fixture with a safety cable (or other secondary attachment) that is approved for the weight of the fixture so that the safety cable will hold the fixture if a primary attachment fails. Loop the safety cable through the attachment point on the back of the fixture. See 'Fixture overview' on page 9 for location.

Fasten the fixture securely with suitable mechanical fasteners. Do not stand it on a surface or leave it where it can be moved or fall over. Ensure that the surface and all fasteners used can support at least 10 times the weight of all fixtures and equipment they will support.

Anchor the mounting yoke bracket to a flat surface. The number and type of fasteners used will depend on the installation, but use at least three high-strength corrosion-resistant fasteners (recommended minimum

properties: stainless steel A4-70 grade according to ISO 3506 or steel grade 8.8 according to ISO 898-1). All nuts used must be self-locking. Washers must be installed between the head of each fastener and the yoke base.

Referring to the illustration below, use a 12 mm (1/2 inch) shaft diameter bolt in the center hole A. Then use either two additional 12 mm bolts passing through holes B or two bolts with 8 mm (5/16 inch) shaft diameter passing through slots C to anchor the fixture. Installing bolts through slots C will give approximately 90° of pan adjustment. If additional bolts are required to mount the fixture safely, install bolts through slots C or holes B.

Install washers under all nuts and bolt heads.

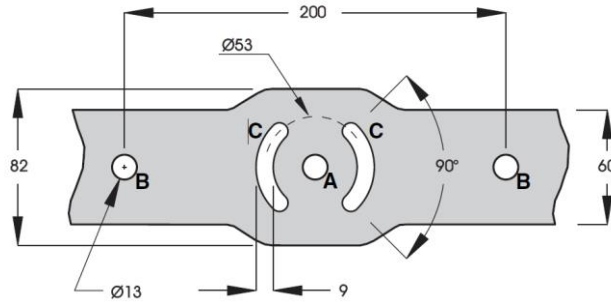

Mounting bracket details

Adjusting tilt



Warning! The fixture can become hot. Wear heat-resistant gloves if you adjust the aim of the fixture when it is (or has recently been) powered on.

Tilt adjustment can be carried out with the fixture powered on as follows.

1. Put on heat-resistant gloves.
2. Loosen, but do not remove, the tilt lock screws (arrowed) on both sides.
3. Tilt the fixture to the desired angle and retighten the screws.

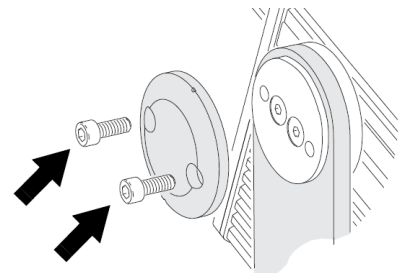

Installing a diffuser

Optional diffuser lenses are available to modify the beam width; see table below for details. The label identifying the nominal diffuser beam angle is partially hidden under the silicone gasket. The diffuser is held in place either by the included trim ring or, if installed, by the snoot.

Diffuser kit	Part number	Nominal half-peak beam angle	Half-peak beam angle, 210 model	Half-peak beam angle, 200 & 220 models
None	-	-	10°	7°
Narrow	91610154	10°	14°	12°
Medium	91610153	20°	22°	21°
Wide	91610152	40°	41°	40°
Very Wide	91610151	60°	61°	60°
Asymmetric	91610150	10° x 60°	14° x 61°	12° x 60°

Exterior Wash™ 200 Series Diffuser Kits

To install an optional diffuser lens:

1. Shut down power to the fixture.
2. Position the diffuser lens over the front with the labelled, smooth side facing out.
3. With the cut-out channels in the silicone gasket facing out, align the channels in the gasket with the drain channels at the bottom of the front ring.
4. Press the diffuser lens gasket firmly into the recess in the front ring.
5. Either place a trim ring over the diffuser and fasten with provided hardware, or install a snoot as described below.

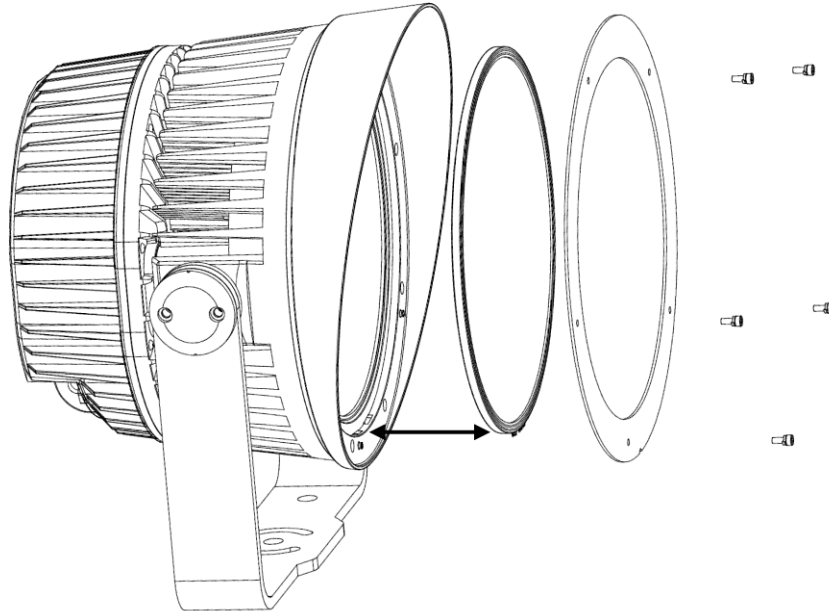

Align channels in gasket and front ring

Installing a snoot

The optional snoot for Exterior Wash™ 200 Series fixtures may be installed with or without a diffuser lens (see above). To install, shut down power to the fixture, then align the snoot to fit over the front of the fixture and fasten securely with the included hardware.

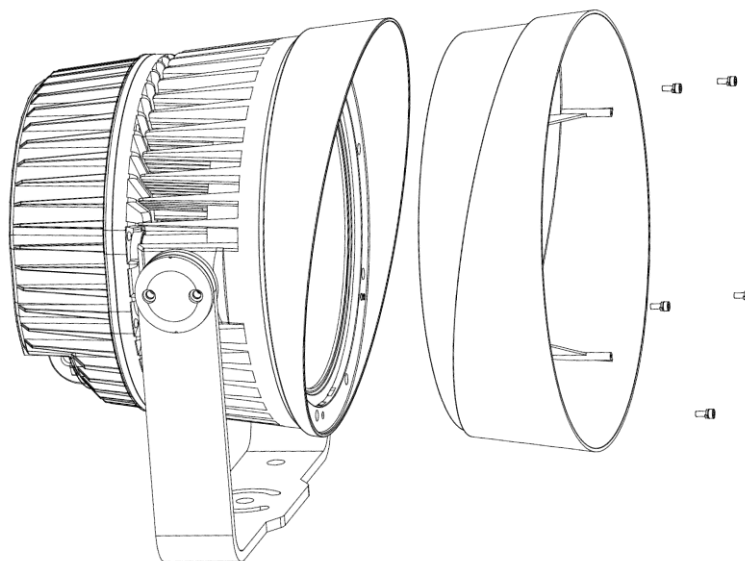

Snoot installation

AC power



Warning! Read “Safety Information” on page 5 before attempting to install an Exterior Wash™ 200 Series fixture. Lock out power to the entire installation before working on cables and connections.



Electrical installation must be carried out by qualified professionals only.

For protection from dangerous electric shock, the fixture must be grounded (earthed). The AC power distribution system must be fitted with current overload and ground-fault (earth-fault) circuit breakers as well as a means to isolate fixtures from power and lock out power during service.

Make sure that cables from fixtures open into dry areas (e.g. junction boxes in dry locations). If there is a break or cut at any point in a cable (for example at a connection point), and if this is exposed to water, moisture can be drawn up the inside of the cable due to the vacuum effect of temperature fluctuations during operation. Ensure that the fixture is protected from the entry of water via the power cable by using IP66-rated connectors or junction boxes, or by protecting connectors with weatherproof housings.

The Exterior Wash™ 200 Series is supplied in EU and US models. Both models accept AC power at 100-240 V nominal or 277 V nominal at 50 or 60 Hz. Do not connect to power at any other voltage or frequency.

You can connect the Exterior Wash™ 200 Series to a single-phase (live, neutral, ground/earth) or to one phase of a grounded/earthed three-phase four-wire (three phases, neutral, ground/earth) power distribution system. Do not try to connect to a three-phase three-wire (three phases, ground/earth) system.

There is no power on/off switch. Power is applied to an Exterior Wash™ 200 Series fixture as soon as it is connected to power. Provide a means to disconnect or shut down power to fixtures that is easily accessible and is located close to the fixtures.

Do not use an external dimming system to supply power to the fixture, as this may cause damage to the fixture that is not covered by the product warranty.

Connecting to power

The fixture is supplied with a power cable installed ready for connection. See illustration below:

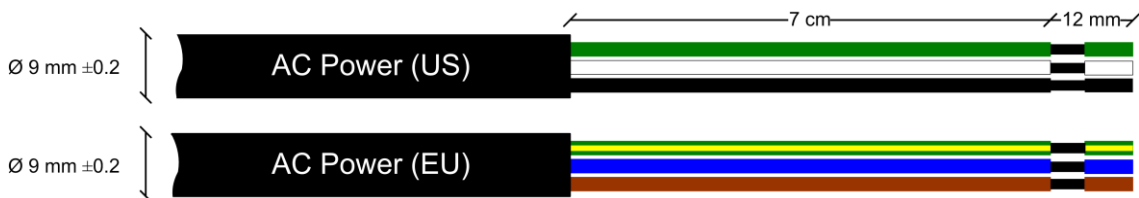

AC power cable details

To connect to a single-phase system or to one phase of a three-phase, four-wire system:

1. Lock out power to the installation.
2. Connect the conductors in the power cable to the distribution circuit as follows:
 - a) Connect the green wire (US models) or yellow/green wire (EU models) to ground (earth).
 - b) Connect the white wire (US models) or blue wire (EU models) to neutral.
 - c) Connect the black wire (US models) or brown wire (EU models) to live (one phase).
3. Check that all installation work is completed and carry out appropriate tests and safety checks before applying power.

If you install a power plug on the power cable for temporary use, install a grounding type (earthed) plug with integral cable grip that is rated minimum 277 V, 6 A. Follow the plug manufacturer's instructions and connect the wires in the power cable as shown in this table:

	Live or L	Neutral or N	Earth, Ground or ⊕
US system	Black	White	Green
EU system	Brown	Blue	Yellow/green

Power plug connections

Control data link



Warning! Make sure that data connections are totally protected from water, or moisture may be drawn up the inside of the cable by the vacuum created by normal heating and cooling.

Connecting the data link

The fixture has a 1.8 m (5.9 ft.) shielded cable with 2 pairs of wire for data connection. The pair of wires marked with a short length of red insulation is for data input. The other pair, marked with a short length of black insulation, is the output to the next device in the daisy chain.



DMX cable details

Data cabling may be connected directly in weatherproof junction boxes or fitted with weatherproof XLR connectors. Protect connectors in a weatherproof housing if they are not totally weatherproof.

Connect the cable as shown in the table below. Do not connect the shield conductor to ground (earth) or allow it to come into contact with a connector shell, as this may cause interference.

Wires	Input pair (red tube)		Output pair (black tube)		Shield
	white	green	white	brown	
Color	white	green	white	brown	black
Signal	DMX in +	DMX in -	DMX out +	DMX out -	common
Male XLR pin	pin 3	pin 2	-	-	pin 1
Female XLR pin	-	-	pin 3	pin 2	pin 1

Data connections

The following considerations must be taken into account when laying out the data network:

- 512 DMX channels are available in a single DMX universe. If the total combined channel requirements of all connected fixtures exceeds 512, one or more additional DMX universes will be required.
- One may reliably connect up to 32 fixtures in a single daisy chain.
- Use RS-485 data cable designed for exterior use. RS-485 cable has low capacitance and a characteristic impedance of 85 to 150 Ohms. It is electrically shielded and has at least 1 twisted pair of conductors. The minimum recommended wire size is 0.25 mm² (24 AWG) for runs up to 200 meters (1000 ft.) and 0.32 mm² (22 AWG) for runs up to 500 meters (1640 ft.).
- Branches may be added to the link using an opto-isolated splitter. To preserve RDM functionality, use an RDM compatible amplifier-splitter such as the Martin 5.5 Splitter™. Each branch may itself connect up to 32 fixtures.
- An RDM amplifier may also be used to extend a network beyond 500 meters (1640 ft.) or to connect up to 32 additional fixtures to the daisy chain.
- The data link and each connected branch must be terminated at the end by placing a 120 ohm resistor (available from Martin, P/N 04150308) across the data output hot (+) and data output cold (-) conductors of the last fixture on the chain.
- Long parallel runs of AC power and control data cables may cause interference on the data link and must be avoided. Even if not required by law, use separate conduits for power and data cables.
- The combined data input/output cable does not support the second DMX data pair. Do not place devices that use the second DMX data pair (connected to XLR pins 4 & 5) on the same daisy chain as Exterior Wash™ fixtures.

Setup



Warning! Read ‘Safety information’ on page 5 before operating the fixture.

This section explains the fixture settings and utilities that the user has access to via the control panel. Settings are retained when the fixture is powered off. A full map of the control menu including default settings can be found on page 22. Some settings and functions are also available by RDM.

Accessing and navigating the control menus

The control panel is located on the back of the fixture. The display can be hidden to deter unauthorized access by the display cover plate, included. Use of the cover plate is optional and not required for weather protection.

To access the control menus, press and hold the MENU button. If prompted for a password, use the arrow buttons to scroll to the 3-digit password and press ENTER when the password is displayed. For more information about password protection of the control menu, see page 19.

Navigate the menu structure using the ENTER, DOWN ARROW (▼) and UP ARROW (▲) buttons. Press ENTER to select and save the desired menu option. To return to the previous level in the menu structure without making a change, press MENU.

To exit the menus, press and hold MENU.

DMX settings

Channel mode

The Exterior Wash 200 and Exterior Wash 210 can be set to use either four or five DMX channels. The four-channel mode is the default. It provides individual control of the red, green, blue, and white levels. The five-channel mode adds dimming control that allows you to vary the intensity without having to change individual color levels.

The channel mode may be set from the control panel or by RDM. To set the Exterior Wash 200 or Exterior Wash 210 channel mode from the control panel:

1. Press and hold the MENU button to access the control menu. If prompted for a password, press the arrow buttons to scroll to the 3-digit password. Press ENTER when the password is displayed.
2. Use the UP and DOWN buttons to select FIXTURE CONFIG from the menu. Press ENTER.
3. Select CHANNEL MODE and press ENTER.
4. The fixture's channel mode setting is displayed. To change the mode setting, press the UP or DOWN button.
5. Press ENTER to store the channel mode setting.
6. Press MENU to exit.

DMX address

The Exterior Wash 200 and Exterior Wash 210 use four or five DMX channels, depending on channel mode. The Exterior Wash 220 uses three DMX channels. The DMX address, also known as the start channel, is the first channel used to receive instructions from a DMX controller. If a fixture that requires 4 DMX channels has its DMX address set to 1, for example, then it uses channels 1, 2, 3 and 4. The next fixture can have its DMX address set to 5, the next to 9 and so on until the 512 channels in one DMX universe are allocated.

For independent control, each fixture must be assigned its own control channels. Two fixtures of the same type (and set to the same channel mode) may share the same address and control channels if identical behavior is desired.

The DMX address may be set from the control panel or by RDM. To set the fixture's DMX address from the control panel:

1. Press and hold the MENU button to access the control menu. If prompted for a password, press the arrow buttons to scroll to the 3-digit password. Press ENTER when the password is displayed.
2. Use the UP and DOWN buttons to select DMX ADDRESS from the menu. Press ENTER.
3. The fixture's DMX address setting is displayed. Press the UP or DOWN button to scroll to the desired DMX address.
4. Press ENTER to store the DMX address setting.
5. Press MENU to exit.

Programming a standalone show

You can program a standalone routine, or show, to run without a controller or if DMX control is suddenly lost. The show can have up to 20 separate effects, or scenes, that display for up to 10 minutes each. Scenes can be programmed to fade from one scene to the next over a period of 0 to 120 seconds.

Note: To enable standalone operation, the DMX STATE setting in the FIXTURE CONFIG menu must be set to SHOW MODE. See page 19. The show will run only when there is no DMX input.

To program a standalone show:

1. Access the control menu and select PROGRAM SHOW. Press ENTER.
2. Set the number of scenes. Select SET SCENE TOTALS and press ENTER. Use the arrow buttons to select from 1 to 20 scenes. Press ENTER.
3. To modify scene colors (on 200 and 210 models) or color temperatures (on the 220 model):
 - a) Select EDIT SCENE COLOR and press ENTER.
 - b) Scroll to a scene to modify and press ENTER.
 - c) Select the attribute to change (red / green / blue / white, or warm white / cold white) and press ENTER.
 - d) Press the UP arrow to increase the attribute or the DOWN arrow to decrease it. When satisfied with the amount, press ENTER.
 - e) Repeat steps c) and d) for each attribute.
 - f) Press MENU to select the next scene to modify.
 - g) When done editing scenes, press MENU again to return to the PROGRAM SHOW menu.
4. To modify scene transitions, select FADE TIME and press ENTER. Press UP or DOWN to select a fade time from 0 to 120 seconds. Press ENTER.
5. To modify the length of time each scene is displayed before fading to the next scene, select HOLD TIME and press ENTER. Press UP or DOWN to select a duration from 0 to 600 seconds. Press ENTER.

Manual mode

Fixture output can be set manually from the control panel as follows:

1. Access the control menu and select MANUAL MODE. Press ENTER.
2. Select an attribute to modify and press ENTER.
3. Adjust the attribute level from 0 to 255 with the arrow buttons. Press ENTER.
4. Repeat for each attribute.
5. To exit manual mode, press MENU.

Display setting

The DISPLAY SETTING menu provides options to invert, dim, and turn off the control panel display.

Display inverse

For easier reading when the fixture is mounted upside down, flip the display as follows:

1. Access the control menu and select DISPLAY SETTINGS. Press ENTER.
2. Select DISPLAY INVERSE and press ENTER.
3. Select YES to invert the display or NO for normal reading.
4. Press ENTER.

Display auto turn off

The display can be set to stay on or to turn off 1 minute after the last key press. To set display behavior:

1. Access the control menu and select DISPLAY SETTINGS. Press ENTER.
2. Select DISPLAY AUTO TURN OFF and press ENTER.
3. Select NO to keep the display illuminated, or YES to have the display turn off automatically after 1 minute.
4. Press ENTER.

Automatic test

The test function allows you to verify LED performance quickly from the control panel. All LEDs are first set to 100 percent. LEDs are then tested together by color (200 & 210 models), or color temperature (220 model). Finally, each LED is tested individually.

To run the automatic test from the control panel, access the control menu, select AUTOMATIC TEST and press ENTER. Press MENU to end the test.

Fixture status

LED temperature, hours, and software version are available from the FIXTURE STATUS menu or RDM.

Fixture config

The FIXTURE CONFIG menu contains additional settings for customizing behavior.

Master/slave

Fixtures operating in stand-alone mode can be linked in a chain for master/slave operation. In this mode, one fixture, the master, controls the other fixtures, the slaves, which fully mimic the master.

Exterior Wash fixtures that use the same color LEDs as their light source can be linked together in master/slave operation. In other words, Exterior Wash 100, 200 and 300 fixtures can be linked together, 110, 210 and 310 fixtures can be linked together, and 120, 220 and 320 can be linked together.

Set all the fixtures except one as slaves. If more than one fixture acts as master, you may cause damage that is not covered by the product warranty.

To operate fixtures in master/slave mode, the fixtures must be connected as described under 'Control data link' on page 15. The master fixture must be programmed to run a stand-alone routine as described under 'Programming a standalone show' on page 17.

Note that if a fixture is set as master it will not respond to DMX and RDM signals. To control the fixture via DMX or communicate with the fixture via RDM, set the fixture to slave again.

If no controller is connected to the link, performance may be improved by terminating the data input of the first fixture.

Enable master/slave operation as follows:

1. On each fixture, access the control menu and select FIXTURE CONFIG. Press ENTER.
2. Select DMX STATE and press ENTER.
3. Select SHOW MODE and press ENTER.
4. Select MASTER/SLAVE from FIXTURE CONFIG menu and press ENTER.
5. The default setting is SLAVE. On one fixture only, select MASTER and press ENTER. Press MENU to exit.
6. On all other fixtures, select MASTER/SLAVE and confirm that they are set to SLAVE. Press MENU to exit.
7. Verify that no DMX control signal is present.

Channel mode

Please see 'DMX settings' on page 16.

Dimmer curve

Four dimming options are available:

- OPTICALLY LINEAR: dimming appears linear as DMX values change.
- SQUARE LAW: dimming is finer at low levels and coarser at high levels.
- INVERSE SQUARE LAW: dimming is coarser at low levels and finer at high levels.
- S-CURVE: dimming is finer at high and low levels, and coarser at medium levels.

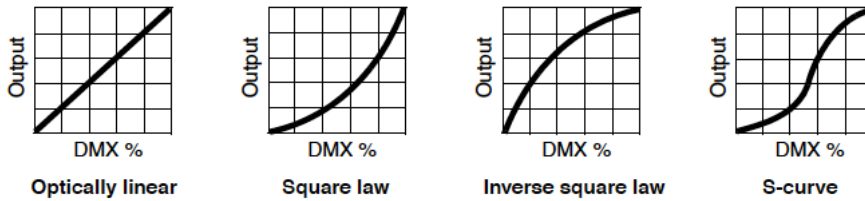

To set the fixture's dimmer curve:

1. Access the control menu and select FIXTURE CONFIG. Press ENTER.
2. Select DIMMER CURVE and press ENTER.
3. Select the option desired from the list above and press ENTER.

Color calibration

The color mixing LEDs in Exterior Wash™ 200 and 210 fixtures are calibrated at the factory for improved uniformity. The calibration factor is not applied by default. To apply color calibration:

1. Access the control menu and select FIXTURE CONFIG. Press ENTER.
2. Select COLOR CALIBRATION and press ENTER.
3. Select YES to apply the factory color calibration, or NO to disable it.
4. Press ENTER.

White balance

White balance can be modified on 200 and 210 models by adjusting the amount of each color mixed in to make white.

1. Access the control menu and select FIXTURE CONFIG. Press ENTER.
2. Select WHITE BALANCE and press ENTER.
3. Select a color to adjust and press ENTER.
4. Press UP or DOWN to increase or decrease the amount of that color in the white balance mix. Press ENTER.
5. Repeat steps 3 and 4 for the other two colors.

DMX state

There are three options for fixture behavior when there is no DMX signal or if the DMX signal is suddenly lost. Note that for stand-alone and master/slave operation, DMX STATE must be set to SHOW MODE.

- SHOW MODE: Fixture executes programmed scenes.
- HOLD LAST LOOK: Fixture holds and displays the last received DMX command.
- BLACKOUT (default): Fixture blacks out.

To set the desired behavior:

1. Access the control menu and select FIXTURE CONFIG. Press ENTER.
2. Select DMX STATE and press ENTER.
3. Press UP or DOWN to select the behavior. Press ENTER.

Display lock

Unauthorized access to the control menu can be prevented by requiring a user-configurable password. This feature is turned off by default. It can be turned on or off as follows:

1. Access the control menu and select FIXTURE CONFIG. Press ENTER.
2. Select DISPLAY LOCK and press ENTER.
3. Select YES to enable password protection or NO to disable it. Press ENTER.

Lock password

The factory default user password is 123. The service password is 111. The user password can be reset to any value from 0 to 999 as described below. The service password cannot be reset. To change the user password:

1. Press and hold the MENU button to access the control menu.
2. If prompted for a password, press the arrow buttons to scroll to the current 3-digit password or the service password (111). Press ENTER when the password is displayed.
3. Select FIXTURE CONFIG from the main menu and press ENTER.

4. Select LOCK PASSWORD and press ENTER.
5. Press the UP or DOWN arrow button to scroll to the desired password. Press ENTER to save it.
6. Record your password inside the front cover of this manual.

Factory reset

To reset all user settings to factory defaults:

1. Access the control menu and select FIXTURE CONFIG. Press ENTER.
2. Select FACTORY RESET and press ENTER.
3. Select YES and press ENTER to confirm, or MENU to escape.

Setup via RDM

The Exterior Wash™ 200 Series is compatible with RDM (Remote Device Management). Using an RDM-compliant DMX controller, you can communicate with Exterior Wash 200 Series fixtures to set DMX addresses, execute other commands, and retrieve basic fixture data via the data link.

To use Martin M-PC, connect a PC running this application to the data link via the Martin M-DMX USB to DMX interface box (see 'Related Items' on page 28). Before you can communicate with fixtures, you will need to send a Scan command from M-PC to detect the devices on the data link.

Maintenance



Warning! There are no user-serviceable parts inside. Do not open the housing. Refer any service operation not described in this manual to Martin Professional or its authorized service agents.

Installation, on-site service and maintenance can be provided worldwide by the Martin Professional Global Service organization and its approved agents, giving owners access to Martin's expertise and product knowledge in a partnership that will ensure the highest level of performance throughout the product's lifetime. Please contact your Martin supplier for details.

Never try to repair the fixture by yourself as this may result in damage or malfunction and it may potentially void your product warranty. The only service operation the user can carry out on Exterior Wash™ 200 Series fixtures is occasional cleaning.

The LED light source in Exterior Wash™ 200 Series fixtures is not user-replaceable. It must be replaced by Martin Global Service or its approved agents only.

Be aware that the output of LEDs, like all light sources, changes gradually over many thousands of hours of use. If you require products to perform to very precise color specifications, you may eventually need to make small readjustments at the lighting controller.

Cleaning

Regular cleaning is essential for fixture life and performance. Buildup of dust and dirt degrades the fixture's light output and cooling ability.

Cleaning schedules will vary greatly depending on the operating environment. It is therefore impossible to specify precise cleaning intervals for the Exterior Wash™ 200 Series. Inspect fixtures within their first few weeks of operation to see whether cleaning is necessary. Check again at frequent intervals. This procedure will allow you to assess cleaning requirements in your particular situation. If in doubt, consult your Martin dealer about a suitable maintenance schedule.

Do not use products that contain solvents, abrasives or caustic agents for cleaning, as they can cause surface damage to the fixture. The aluminum housing and front glass can be cleaned with mild detergents such as those for washing cars.

To clean the housing and front glass:

1. Isolate the fixture from AC power and allow the fixture to cool for 20 minutes.
2. Visually check that the silicone seals and the power and data cables are in good condition. If any seal or cable shows signs of damage, cracking or loss of water resistance, stop cleaning the fixture and contact a Martin authorized service technician for replacement.
3. If seals are in good condition, rinse off loose dirt with a hose or low-pressure water spray.
4. Wash the aluminum housing and front glass using warm water with a little mild detergent and a soft brush or sponge. Do not use abrasive cleaners.
5. Rinse with clean water and wipe dry.

Pressure relief valve

A valve with a Gore-Tex membrane on the back of the fixture equalizes pressure by allowing air to pass through it when the fixture heats up and cools down, but at the same time it acts as a barrier to water in liquid form. The expulsion of warm air (with a slightly higher water vapor content) and intake of cool air (with a slightly lower water vapor content) prevents humidity buildup over time, provided that the valve works correctly and the fixture is correctly sealed.

Pressure relief valves have a limited service life. They become blocked over time as the micropores in the membrane fill with particles. When a valve becomes blocked, excess pressure can damage seals or cause air and even water to be sucked into the fixture along cables. A blocked valve cannot be cleaned and must be replaced if it shows any signs of contamination or is not in perfect condition.

For maximum fixture service life, have the pressure relief valve replaced after an extended period of use. Intervals for valve replacement depend on the installation environment. Please consult your Martin dealer about a suitable replacement schedule.

Contact Martin™ Service for valve replacement.

DMX protocol

Exterior Wash 200 and Exterior Wash 210

These fixtures have two DMX control modes. See 'Channel mode' on page 16 for details.

Four-channel mode

Four-channel mode provides individual 0 to 100% control of each color.

Channel	Value	Function
1	0-255	Red: 0-100%
2	0-255	Green: 0-100%
3	0-255	Blue: 0-100%
4	0-255	White: 0-100%

Five-channel mode

Five-channel mode allows you to mix colors and vary intensity on channel 1.

Channel	Value	Function
1	0-255	Dimmer 0-100%
2	0-255	Red: 0-100%
3	0-255	Green: 0-100%
4	0-255	Blue: 0-100%
5	0-255	White: 0-100%

Exterior Wash 220

The DMX protocol provides individual 0 to 100% control of the warm and cold LEDs on channels 1 and 2. Channel 3 provides color temperature control from warm to cold at maximum output. When set to a level above 26, channel 3 overrides channels 1 and 2.

Channel	Value	Function
1	0-255	Warm White 0-100%
2	0-255	Cold White 0-100%
3		Color Temperature
	0-27	Disabled
	28-65	Color Temperature from 2800 to 6500 K in approx. 100K steps (Cold and Warm LED channels are disabled)
	66-225	6500 K

Control menus

To access the control menu, press and hold the MENU button. If prompted, scroll to the user password and press ENTER. Press ▼ (down) and ▲ (up) buttons to navigate the menus. Press ENTER to select a menu option. For more information, see 'Accessing and navigating the control menus' on page 16.

The factory default settings are shown in bold.

Menu	Sub-menus		Explanation	
DMX Address	1- 512		DMX start channel	
Program Show	Set Scene Totals	1-20	Number of stand-alone scenes	
	Edit Scene Color (200 & 210 models)	1- last scene	Red	0-255
			Green	0-255
			Blue	0-255
			White	0-255
	Edit Scene Color (220 model)	1- last scene	Cold white	0-255
Warm white			0-255	
Fade Time	0-120 secs. (3 secs.)		Transition time between scenes	
Hold Time	0-600 secs. (1 sec.)		Length of time scenes are displayed	
Manual Mode (200 & 210)	Red	0-255	Manually adjust output	
	Green	0-255		
	Blue	0-255		
	White	0-255		
Manual Mode (220)	Warm White	0-255	Manually adjust output	
	Cold White	0-255		
Display Setting	Display Inverse	No/Yes	Flip display	
	Display Auto Turn Off	No/Yes	Switch off display 1 min. after last key press	
Automatic Test	-		Lights LEDs together, by color, and individually	
Fixture Status	LED Temperature		Temperature of onboard sensor	
	Power On Hours		Fixture operating hours counter	
	LED On Hours		LED hours counter	
	RDM device UID		Fixture's unique RDM ID	
	Software Version		Currently installed firmware version	
Fixture Config	Master/Slave	Master	Set master fixture	
		Slave	Set slave fixture	
	Channel Mode (200 & 210 models)	4 Channel Mode	Individual color control	
		5 Channel Mode	Color mixing with dimmer	
	Dimmer Curve	Optically Linear	Dimming behavior (see page 18)	
		Square Law		
		Inverse Square Law		
		S-Curve		
	Color Calibration (200 & 210 models)	No/Yes		Apply factory color calibration
	White Balance (200 & 210 models)	Red (90% - 100%)		Amount of each color used to make white
Green (90% - 100%)				
Blue (90% - 100%)				

Fixture Config (contd.)	DMX State	Show Mode	Behavior when no DMX control signal present
		Hold Last Look	
		Black Out	
	Display Lock	No/Yes	Password protect control menu
	Lock Password	0 – 999 (123)	Set user password
Factory Reset	No/Yes	Restore all settings to factory defaults	

Troubleshooting

Problem	Probable cause(s)	Remedy
Fixture is completely dead.	No power to fixture. Primary fuse blown.	Check power source and connections. Isolate fixture from power. Contact Martin™ Service for assistance.
One or more fixtures responds incorrectly to control or does not respond at all.	Incorrect DMX addressing. Incorrect channel mode. Fault on DMX link. Electromagnetic interference on DMX link Fixture defective. Other device on DMX link defective.	Check number of DMX channels required by each fixture and check DMX addresses on fixtures and DMX controller. Verify CHANNEL MODE setting. Inspect connections and cables. Correct poor connections. Repair or replace damaged cables. Move cables away from any strong electromagnetic fields. Have faulty fixture serviced by Martin™ Service. Bypass devices on DMX link until the faulty device has been identified. Have faulty device serviced by Martin™ Service or device supplier.
LEDs cut out intermittently.	Fixture is too hot.	Ensure free airflow around fixture. Clean fixture. Check that ambient temperature does not exceed maximum permitted level. Contact Martin™ Service for assistance.

Specifications

Physical

Length	270 mm (10.7 in.)
Width	334 mm (13.2 in.)
Height	382 mm (15.1 in.)
Weight	13.0 kg (28.7 lbs.)

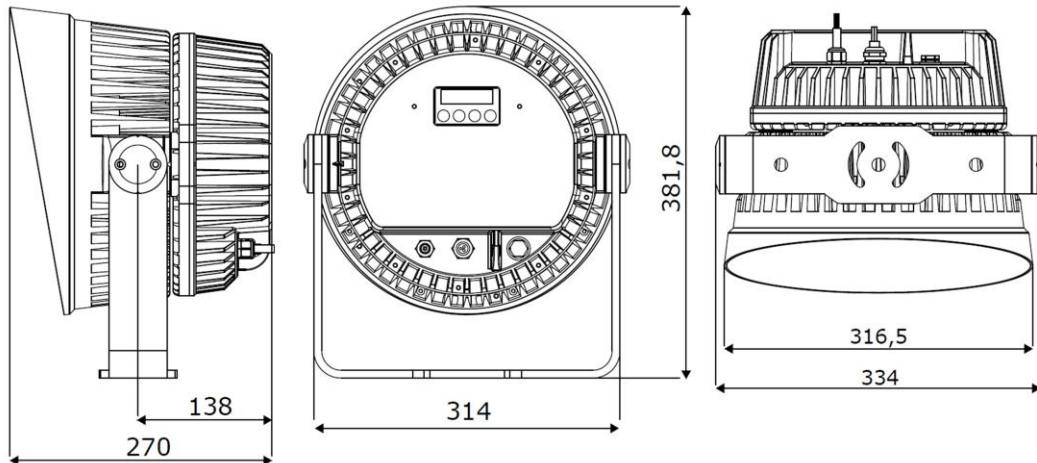

Dynamic Effects

All models

Intensity	0 - 100%
-----------------	----------

Exterior Wash 200 and 210

Color mixing	RGBW
--------------------	------

Exterior Wash 220

Color temperature control	2800 K - 6500 K
---------------------------------	-----------------

Control and Programming

All models

Control systems	DMX, RDM
Setting, addressing, standalone programming	Control panel with OLED display
Receiver	RS-485
Firmware update	Serial upload via DMX link
DMX compliance	USITT DMX512-A
RDM compliance	ANSI/ESTA E1.20

Exterior Wash 200 and 210

DMX channels	4 or 5
--------------------	--------

Exterior Wash 220

DMX channels	3
--------------------	---

Optics

All models

Minimum LED lifetime	50 000 hours (to >70% luminous output)*
----------------------------	---

*Figure obtained under manufacturer's test conditions

Exterior Wash 200

Light source	68 single-color LEDs (16 R, 18 G, 16 B, 18 W)
Half-peak beam angle	7°
Beam angles available with accessory diffusers	12°, 21°, 40°, 60°, 12° x 60°

Exterior Wash 210

Light source	19 quad-color RGBW LEDs
Half-peak beam angle	10°
Beam angles available with accessory diffusers	10°, 14°, 22°, 41°, 61°, 14° x 61°

Exterior Wash 220

Light source	34 x 2800 K warm white and 34 x 6500 K cold white LEDs
Half-peak beam angle	7°
Beam angles available with accessory diffusers	12°, 21°, 40°, 60°, 12° x 60°

Construction



Protection rating IP66
 Color Clear anodized (standard), black or white (optional)
 Housing Cast aluminum
 Effective Projected Area (EPA) 0.1 m² (1.1 ft²)
 Impact resistance IK08
 RoHS Compliant

Installation

Orientation Any
 Mounting Adjustable yoke
 Minimum distance to illuminated surfaces 0.2 m (0.6 ft.)

Connections

Power connection 1.8 m (5.9 ft.) cable tail without connector
 Data I/O 1.8 m (5.9 ft.) open ended 5-conductor cable tail
 Cable entry IP68 cable gland

Electrical

AC power 100-240/ 277 V nominal, 50/60 Hz
 Power supply unit Integrated, auto-sensing multi-voltage

Typical power and current

All models

Typical half-cycle RMS inrush current at 240VAC 10.3 A

Exterior Wash 200

100 V, 60 Hz 1.7 A, 170 W, PF 0.99
 120 V, 60 Hz 1.4 A, 170 W, PF 0.99
 230 V, 50 Hz 0.8 A, 170 W, PF 0.95
 277 V, 60 Hz 0.7 A, 170 W, PF 0.85

Exterior Wash 210

100 V, 60 Hz 1.6 A, 160 W, PF 0.99
 120 V, 60 Hz 1.3 A, 160 W, PF 0.99
 230 V, 50 Hz 0.7 A, 160 W, PF 0.95
 277 V, 60 Hz 0.7 A, 160 W, PF 0.87

Exterior Wash 220

100 V, 60 Hz 1.7 A, 170 W, PF 0.99
 120 V, 60 Hz 1.4 A, 170 W, PF 0.99
 230 V, 50 Hz 0.8 A, 170 W, PF 0.95
 277 V, 60 Hz 0.7 A, 170 W, PF 0.89

Measurements made at nominal voltage. Allow for a deviation of +/- 10%.

Thermal

Cooling Convection
 Maximum ambient temperature (Ta max.) 45° C (113° F)
 Minimum ambient temperature (Ta min.) -30° C (-22° F)
 Power must be maintained below 0° C (32° F)
 Maximum surface temperature, steady state, at 45° C ambient 55° C (131° F)
 Total heat dissipation (calculated, +/- 10%) 640 BTU/hr.

Approvals



EU safety EN60598-2-5 (EN60598-1), EN62471, EN62493, EN60598-2-1
 EU EMC EN55015, EN61547, EN61000-3-2 & 3-3, EN61000-4-2, EN6100-4-4 & 4-5
 US safety ANSI/UL 1598
 US EMC CFR Title 47 Part15 Class A
 Canadian safety CSA C.22.2 No. 250
 Australia/NZ RCM

Included Items

- User manual
- Control panel cover plate

Accessories

- Exterior Wash 200 Series, narrow beam diffuser kit P/N 91610154
- Exterior Wash 200 Series, medium beam diffuser kit P/N 91610153
- Exterior Wash 200 Series, wide beam diffuser kit P/N 91610152
- Exterior Wash 200 Series, very wide diffuser kit P/N 91610151
- Exterior Wash 200 Series, asymmetric diffuser kit P/N 91610150
- Exterior Wash 200 Series, glare shield / snoot P/N 91611745

Related Items

- Martin™ M-PC 2U incl. Martin™ M-DMX Interface Box and USB cable P/N 90737070

Ordering Information

- Exterior Wash 200, 7°, EU, aluminum..... P/N 90509087
- Exterior Wash 200, 7°, US, aluminum..... P/N 90509090
- Exterior Wash 210, 10°, EU, aluminum..... P/N 90509088
- Exterior Wash 210, 10°, US, aluminum..... P/N 90509095
- Exterior Wash 220, 7°, EU, aluminum..... P/N 90509089
- Exterior Wash 220, 7°, US, aluminum..... P/N 90509091

Specifications subject to change without notice. For latest product specifications, see www.martin.com

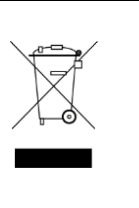
	<p>Disposing of this product</p> <p>Martin™ products are supplied in compliance with Directive 2012/19/EC of the European Parliament and of the Council of the European Union on WEEE (Waste Electrical and Electronic Equipment), where applicable. Help preserve the environment! Ensure that this product is recycled at the end of its life. Your supplier can give details of local arrangements for the disposal of Martin products</p>
---	--

Photobiological Safety Warning

The label shown below is displayed on this product. If it becomes difficult or impossible to read, it must be replaced using the illustration below to reproduce a new label sized 58 x 16 mm, in black with a yellow border.

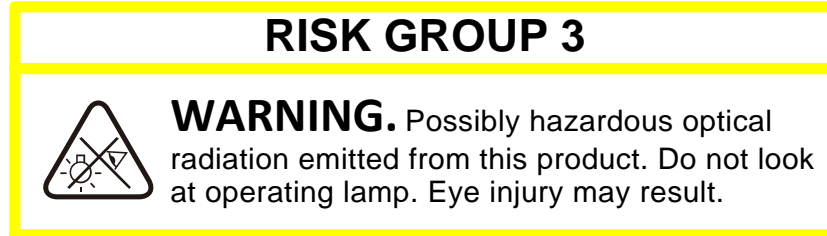



www.martin.com · Olof Palmes Allé 18 · 8200 Aarhus N · Denmark
Tel: +45 8740 0000 · Fax +45 8740 0010