

Exterior Dot-HP™ User Manual



Please check that you have the latest user manual for this product before installing, operating or servicing the product.

User manual revisions are identified at the bottom of page 2. You can download the latest user documentation from the Product Support / Tech Docs pages at www.martin.com

Martin[®]
by HARMAN

Dimensions

Exterior Dot-HP, clear front

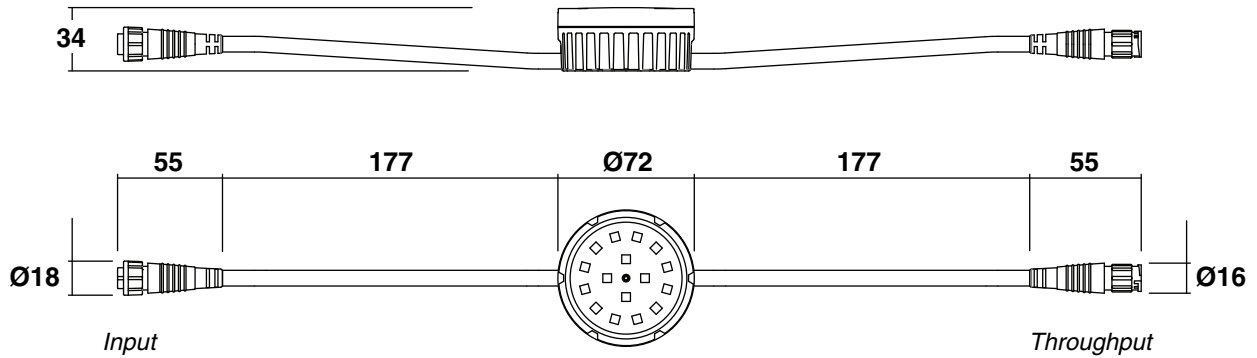

Exterior Dot-HP, diffuser dome front

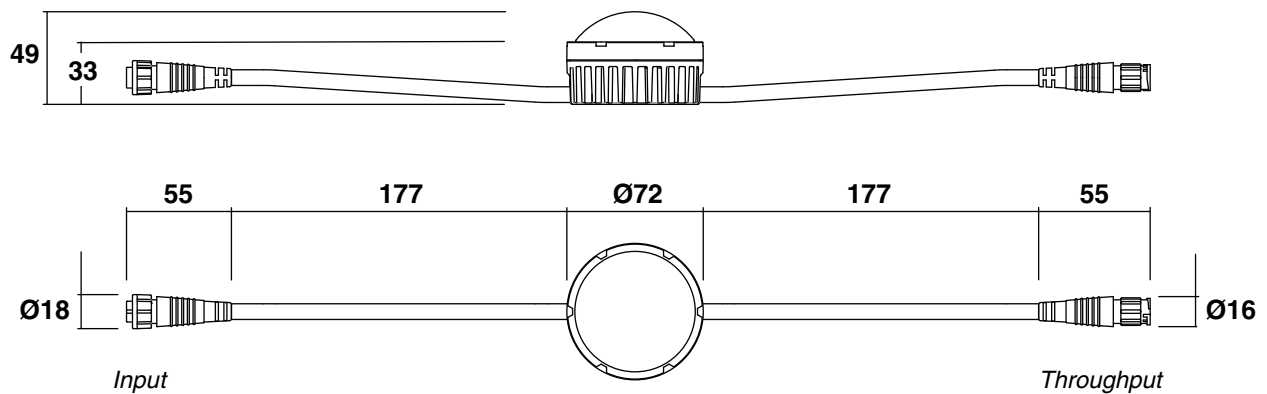

Direct dot-to-dot connection allows up to 0.5 m (19.6 in.) pixel pitch

All dimensions are in millimeters

© 2015-2016 Martin Professional ApS. Information subject to change without notice. Martin Professional and all affiliated companies disclaim liability for any injury, damage, direct or indirect loss, consequential or economic loss or any other loss occasioned by the use of, inability to use or reliance on the information contained in this document. The Martin logo, Martin name, Harman name and all other trademarks in this document pertaining to services or products by Martin Professional or its affiliates and subsidiaries are trademarks owned or licensed by Martin Professional or its affiliates or subsidiaries.

Exterior Dot-HP™ User Manual P/N 5080227 Rev. A (preliminary)

Exterior Dot-HP mounting plate

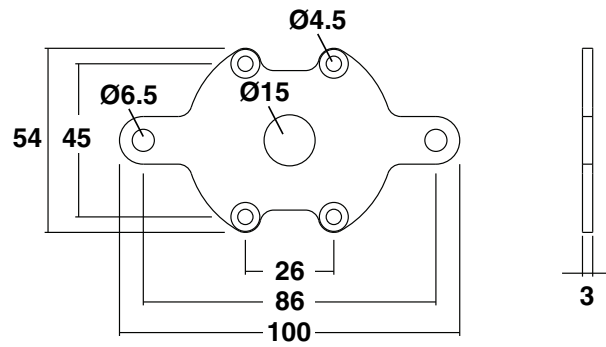

Exterior Dot-HP mounting profile

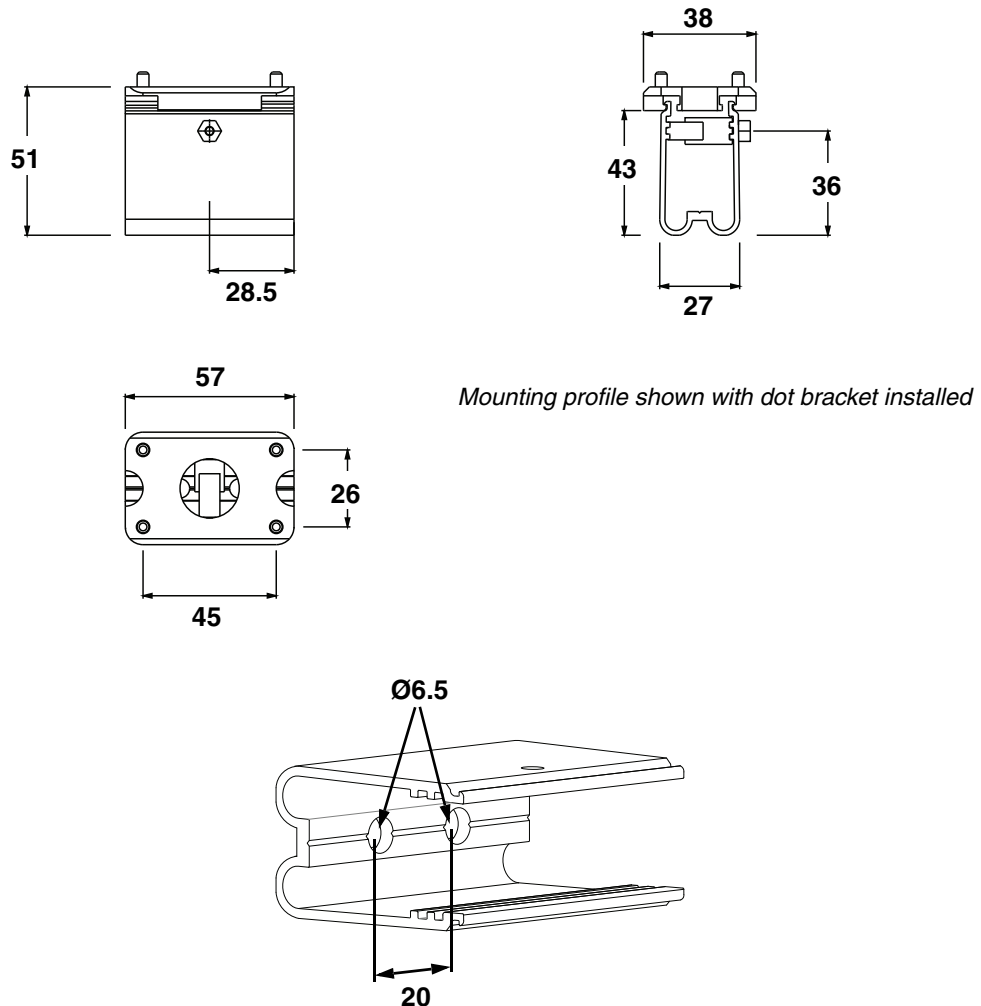

All dimensions are in millimeters

Contents

Dimensions	2
Safety information	5
Introduction	10
Precautions to avoid damage	11
Exterior Dot-HP™ overview	12
Physical installation	13
Avoiding damage	13
Mounting on a surface or structure	14
Installing using mounting profile	15
System installation	17
Installing a P3 system	17
Installing a DMX-controlled system	19
System setup	24
Setting up for P3 display	24
Setting up for DMX control	24
RDM	25
Using the Exterior Dot-HP™	26
Thermal regulation	26
P3 display	26
DMX control	26
Magnetic 'control button'	27
Service and maintenance	30
Cleaning	30
Condensation and pressure relief valve	30
LED performance	30
Installing new software	31
Troubleshooting	32
DMX protocols	33
RGB Mode	33
Basic Mode	33
Pre-programmed FX	34
Specifications	35

Safety information



WARNING!

Read the safety precautions in this section before installing, powering, operating or servicing this product.

The following symbols are used to identify important safety information on the product and in this document:



Warning!
Safety hazard.
Risk of severe injury or death.



Warning!
Hazardous voltage. Risk of severe or lethal electric shock.



Warning!
Fire hazard.



Warning!
Burn hazard.
Hot surface with risk of burns.



Warning!
Refer to user manual.



Warning!

- **Check the Exterior Dot-HP™ Product Support / Tech Docs page on the Martin™ website at www.martin.com and make the sure that you have the latest user documentation for the product. Martin™ user manual revisions are identified at the bottom of page 2.**
- **Read the latest revision of the user manual before installing, operating or servicing the Martin Exterior Dot-HP™.**
- **Follow the safety precautions given in this user manual and in the manuals of all the devices you connect to the product. Observe all warnings given in manuals and printed on devices. Make sure that everyone who is involved in working on or using the product has read and understood these safety precautions and warnings.**
- **Install, connect, operate and service devices only as described in this user manual and in connected devices' user documentation and only in accordance with local laws and regulations. All Martin™ user documentation is supplied with devices and available for download from www.martin.com.**
- **This product is suitable for installations where chains of Exterior Dot-HP™ dots are located outdoors, provided that either:**
 - **Each chain is connected to a device that is earthed (grounded) such as a Martin™ P3 PowerPort or a Martin™ IP66 PSU 240W device and maximum 10 m (32 ft.) total in length, or**
 - **Each chain is secured directly to an earthed (grounded) metal structure.**

The above conditions are based on the provisions of Installation Class 3, EN 61000-4-5, under which surges may not exceed 2 kV.
- **This product is not for household use. It presents risks of severe injury or death due to fire and burn hazards, electric shock and falls. It must be installed by qualified technicians only.**
- **This product does not have user-serviceable parts. Refer any operation not described in this manual to Martin™ Global Service or a Martin™ authorized service agent.**

If you have any questions about how to operate this product safely, please contact your Martin™ supplier or call the Martin™ 24-hour service hotline on +45 8740 0000, or in the USA on 1-888-tech-180.



PROTECTION FROM ELECTRIC SHOCK

- Read and respect the directions given in the user documentation of all the devices that you intend to connect to the Exterior Dot-HP™, particularly the instructions, warnings and limits that apply to:
 - system layout,
 - connections to other devices,
 - specified cables,
 - maximum cable lengths, and
 - maximum number of devices that can be connected.
- Use only the cables specified in this manual and on the Martin™ website at www.martin.com to interconnect devices in the installation. If the specified cables are not long enough for an intended cable run, consult Martin™ for assistance in finding or creating a safe alternative solution.
- Provide a means of locking out AC mains power so that power to the installation can be shut down and made impossible to reapply, even accidentally, during work on the installation.
- Shut down power to the installation during service and when it is not in use.
- Before applying power to the installation, check that all power distribution equipment and cables are in perfect condition and rated for the current requirements of all connected devices.
- Isolate the installation from power immediately if any product, power cable or power plug is in any way damaged, defective, or if it shows signs of overheating.
- Do not immerse the Exterior Dot-HP™ in water.
- If you supply a chain of Exterior Dot-HP™ dots with DC power from a **generic 48 VDC external PSU** and the DC output used does not have constant overcurrent protection that limits current to 7.5 A, install an inline fuseholder with a 7.5 A fuse on the circuit that you connect to that DC output.
- Do not allow the total number of dots in a linked chain of Exterior Dot-HP™ dots to exceed the safe limits given in the tables in the following section of this manual.

Safety limits for connecting devices

This user manual (Revision A) contains preliminary information on safety limits for connecting devices. We are currently (from November 2016) preparing more complete information on the maximum number of Exterior Dot-HP™ dots that can be interconnected in a chain and the maximum permitted length of a chain, and we will publish this information in a later revision of the manual. In the meantime, please respect the limits given here.

Do not exceed the maximum safety limits given below and in the following tables.:

- The maximum permitted total length of a chain of Exterior Dot-HP™ dots is **120 m (394 ft.)**. When you calculate the total length of the chain, include the cable tails on dots (1 meter or 3.3 feet per dot) plus the lead-in cable (cable between the DC power source and the first Exterior Dot-HP™ dot), plus all extension cable added between dots.
- The maximum permitted length of a lead-in cable is **100 m (328 ft.)**.
- The maximum permitted length of cable between two Exterior Dot-HP™ dots is **20 m (65 ft.)**. If you need a distance longer than 20 m between two dots, create a new chain of dots with its own power and data source.
- The maximum number of Exterior Dot-HP™ dots that you can connect in one chain depends on the following:
 - type of device used as DC power source
 - length of chain from DC power source to last Exterior Dot-HP™ dot in chain
 - calibration mode of Exterior Dot-HP™ dots: uncalibrated or calibrated mode.

Do not exceed the limits given in the following sections.

Martin P3 PowerPort 1500™ safety limits

If you supply Exterior Dot-HP™ dots with DC power from a Martin P3 PowerPort 1500™:

- Do not connect more than one chain of dots per DC output on the P3 PowerPort 1500™. Since the P3 PowerPort 1500™ has four DC outputs, you can connect a maximum of four chains of dots to one P3 PowerPort 1500™.
- Check whether there is a possibility that the dots may be used in uncalibrated mode or whether the dots will be used in calibrated mode **only**:
 - If there is a possibility that the dots may be used in uncalibrated mode, consult the figures for 'Uncalibrated mode or mixed calibrated and uncalibrated modes' in Table 1.
 - If the dots will be used in calibrated mode **only**, consult the figures for 'Calibrated mode only' in Table 1.

- Do not exceed the maximum total number of dots that you can include in one chain for the total cable lengths listed in Table 1. If the total cable length is not given in the table, respect the maximum total number of dots given for the next highest length. In other words, if you create a cable with a total length of 46 m, do not exceed the maximum total number of dots for a chain with a 70 m cable length.

		Maximum permitted number of dots in chain
Uncalibrated mode or mixed calibrated and uncalibrated modes (7 W per dot)	45 m (147 ft.) total cable length	44
	70 m (230 ft.) total cable length	41
	115 m (377 ft.) total cable length	33
Calibrated mode only (5 W per dot)	45 m (147 ft.) total cable length	63
	70 m (230 ft.) total cable length	58
	115 m (377 ft.) total cable length	48

Table 1: Max. number of Exterior Dot-HP™ dots per P3 PowerPort 1500™ output

Martin P3 PowerPort 1000 IP™ safety limits

If you supply Exterior Dot-HP™ dots with DC power from an output on a Martin P3 PowerPort 1000 IP™:

- Do not connect more than one linked chain of Exterior Dot-HP™ dots to one DC output. Since the P3 PowerPort 1000 IP™ has four DC outputs, you can connect a maximum of four chains of dots to one P3 PowerPort 1000 IP™.
- Check whether there is a possibility that the dots may be used in uncalibrated mode or whether the dots will be used in calibrated mode **only**:
 - If there is a possibility that the dots may be used in uncalibrated mode, consult the figures for 'Uncalibrated mode or mixed calibrated and uncalibrated modes' in Table 2.
 - If the dots will be used in calibrated mode **only**, consult the figures for 'Calibrated mode only' in Table 2.
- Do not exceed the maximum total number of dots that you can include in one chain for the total cable lengths listed in Table 2. If the total cable length is not given in the table, respect the maximum total number of dots given for the next highest length. In other words, if you create a cable with a total length of 46 m, do not exceed the maximum total number of dots for a chain with a 70 m cable length.

		Maximum permitted number of dots in chain
Uncalibrated mode or mixed calibrated and uncalibrated modes (7 W per dot)	45 m (147 ft.) total cable length	30
	70 m (230 ft.) total cable length	29
	115 m (377 ft.) total cable length	25
Calibrated mode only (5 W per dot)	45 m (147 ft.) total cable length	45
	70 m (230 ft.) total cable length	42
	115 m (377 ft.) total cable length	37

Table 2: Max. number of Exterior Dot-HP™ dots per P3 PowerPort 1000 IP™ output

Martin™ IP66 PSU 240W safety limits

If you supply Exterior Dot-HP™ dots with DC power from a **Martin™ IP66 PSU 240W external power supply unit**:

- Do not connect more than one linked chain of Exterior Dot-HP™ dots to the DC power output of the Martin™ IP66 PSU 240W.
- Check whether there is a possibility that the dots may be used in uncalibrated mode or whether the dots will be used in calibrated mode **only**:
 - If there is a possibility that the dots may be used in uncalibrated mode, consult the figures for ‘Uncalibrated mode or mixed calibrated and uncalibrated modes’ in Table 3.
 - If the dots will be used in calibrated mode **only**, consult the figures for ‘Calibrated mode only’ in Table 3.
- Do not exceed the maximum total number of dots that you can include in one chain for the total cable lengths listed in Table 3. If the total cable length is not given in the table, respect the maximum total number of dots given for the next highest length. In other words, if you create a cable with a total length of 46 m, do not exceed the maximum total number of dots for a chain with a 70 m cable length.

		Maximum permitted number of dots in chain
Uncalibrated mode or mixed calibrated and uncalibrated modes (7 W per dot)	45 m (147 ft.) total cable length	29
	70 m (230 ft.) total cable length	28
	115 m (377 ft.) total cable length	24
Calibrated mode only (5 W per dot)	45 m (147 ft.) total cable length	42
	70 m (230 ft.) total cable length	40
	115 m (377 ft.) total cable length	36

Table 3: Max. number of Exterior Dot-HP™ dots per Martin™ IP66 PSU 240W

Generic 48 VDC external PSU safety limits

If you supply a chain of Exterior Dot-HP™ dots with DC power from a **48 VDC external PSU (power supply unit) that is not from Martin™**, you must not exceed the **maximum power rating of the output from the PSU**. Follow these instructions:

- Check whether there is a possibility that the dots may be used in uncalibrated mode or whether the dots will be used in calibrated mode **only**:
 - If there is a possibility that the dots may be used in uncalibrated mode, allow a power consumption of 7 watts per dot.
 - If the dots will be used in calibrated mode **only**, allow a power consumption of 5 watts per dot.
- Calculate the total power consumption in watts of the dots in each chain you plan to create. Do not create a chain that will exceed the maximum power rating of the PSU output used to supply that chain with power. Each time the total power consumption in watts for one chain reaches the PSU output’s maximum power rating, you must create a new chain of dots that is connected to a new 48 VDC power output.
- Do not exceed the maximum total number of dots that you can include in one chain for the total cable lengths listed in Table 4. If the total cable length is not given in the table, respect the maximum total number of dots given for the next highest length. In other words, if you create a cable with a total length of 46 m, do not exceed the maximum total number of dots for a chain with a 70 m cable length.

		Maximum permitted number of dots in chain
Uncalibrated mode or mixed calibrated and uncalibrated modes (7 W per dot)	45 m (147 ft.) total cable length	29
	70 m (230 ft.) total cable length	28
	115 m (377 ft.) total cable length	24
Calibrated mode only (5 W per dot)	45 m (147 ft.) total cable length	42
	70 m (230 ft.) total cable length	40
	115 m (377 ft.) total cable length	36

Table 4: Max. number of Exterior Dot-HP™ dots per generic 240 watt external PSDU



PROTECTION FROM BURNS AND FIRE

- The Exterior Dot-HP™ is cooled by convection. Provide free airflow and a minimum clearance of 10 mm (0.4 in.) around the product.
- Do not operate the Exterior Dot-HP™ if the ambient temperature (Ta) exceeds 55° C (131° F).
- The surface of the product can become hot when in use. Take precautions to avoid accidental skin contact.
- Do not modify the Exterior Dot-HP™ in any way not described in this manual or install other than genuine Martin™ parts. Use only accessories approved by Martin™.



PROTECTION FROM INJURY



- Read carefully the chapter “Physical installation” on page 13 and respect the limits and instructions given in that chapter.
- Ensure that the installation hardware and supporting surface or structure can hold at least 10 times the weight of all the devices they support.
- Block access below the work area and work from a stable platform whenever installing, servicing or moving the Exterior Dot-HP™.
- Make sure that all items are securely installed, taking into consideration all possible environmental conditions including temperature variation and wind. Make sure that it is impossible for items to fall and cause injury or damage.
- Use grade 8.8 strength fasteners that are suitable for their purpose and for the installation environment.
- Fasten Exterior Dot-HP™ products to the supporting surface or structure with a minimum of two fasteners (screws, bolts, etc.) per product.
- Either use self-locking nuts or use lockwashers with standard nuts on all machine screws and bolts.

Introduction

Thank you for selecting a product from the Martin Exterior Dot-HP™ family. These compact LED-based display fixtures are designed to integrate into a Martin P3™ video system, where they can display video from a variety of sources. Each fixture forms one pixel in the video display. As well as video, the Exterior Dot-HP™ can be controlled using a DMX lighting controller. Use of an RDM-compliant DMX controller such as the Martin M-PC™ also allows two-way communication and remote management of Exterior Dot-HP™ fixtures from the controller.

The Exterior Dot-HP™ has an array of LEDs in a circular cast aluminum housing with a front cover that is permanently sealed onto the unit to give a rugged IP66-rated dot. Dots are supplied in clear front, diffuser dome and directional front versions. All versions are available as either RGB or CW (cool white) models, and various mounting options are available from Martin™ (see “Accessories” on page 36).

A hybrid (combined power and data) cabling system allows Exterior Dot-HP™ dots to be daisy-chained for easy setup and minimal cabling.

The Exterior Dot-HP™ system offers the following features:

- IP66-rated dots and connectors
- Fast, flexible mounting options
- Range of optical variants
- Individually controllable red, green and blue pixel groups in RGB dots
- High-quality 16-bit per color RGB image processing technology in RGB dots
- Pixel-level brightness and color calibration for optimal image quality
- P3 video and DMX lighting control with automatic protocol detection
- Intuitive pixel mapping and addressing using a controller from the Martin P3™ system controller range
- Single hybrid cable carrying both power and data
- External power and data processor from the Martin P3 PowerPort™ range and simple cabling system
- Corrosion resistance to C5-M (very high corrosivity environments including marine / coastal / offshore according to ISO 12944).
- Clear anodized finish as standard, with custom RAL colors available by special order

For detailed dimensions drawings in various file formats of all the products in the Exterior Dot-HP™ family, please see the Exterior Dot-HP™ Tech Docs / Product Support pages on the Martin™ website at www.martin.com

Martin™ user documentation is supplied with products and available for download from www.martin.com, where you can also find the latest specifications, firmware updates and support information for all Martin™ products. Before you install or use the Exterior Dot-HP™, please check www.martin.com and make sure that you have the latest user documentation for this product. Martin™ user documentation revisions are identified at the bottom of page 2.

At Martin™ we welcome input from users. Comments or suggestions regarding this manual can be e-mailed to service@martin.dk or posted to: User Documentation, Martin Professional ApS, Olof Palmes Allé 18, DK-8200 Aarhus N, Denmark.

Precautions to avoid damage

Important! To get the best out of the Exterior Dot-HP™ and avoid causing damage that is not covered by the product warranty, make sure that everyone who is involved in installing, working on or using the Exterior Dot-HP™ has read and understood the following information.

Cleaning

Excessive dirt buildup causes overheating and may lead to damage that is not covered by the product warranty. Clean the product at regular intervals (see “Cleaning” on page 30).

Operating temperature precautions

- Do not operate the Exterior Dot-HP™ in an ambient temperature that exceeds the specified maximum of 55° C (131° F) for showing average video content.
- Exterior Dot-HP™ dots have an internal thermal sensor. If the sensor measures excessive temperature, a thermal protection cutout shuts down the dot. The dot will not function normally again until the temperature has fallen to a safe level.
- When using a Martin P3™ System Controller you can enable "thermal throttling" functionality. This feature gradually dims dots if they get hot, avoiding full thermal shutdowns.

Sealing unused connectors with blanking caps

Blanking caps for female BBD connectors can be ordered separately in sets of 10 (see “Connectors” on page 37). Install blanking caps on all unused female BBD connectors to seal them against water and dirt, otherwise short-circuits and damage may occur.

Maintaining IP66 protection

The Exterior Dot-HP™ is supplied as a sealed unit. Do not try to remove optical components or disassemble the product in any other way or you will affect the product’s IP66-rated weatherproofing, which may cause the product to malfunction and lead to damage.

Pressure relief vent

A vent with a Gore-Tex membrane in the base of the product equalizes pressure by allowing air to pass through it when the product heats up and cools down, but at the same time it acts as a barrier to water in liquid form. The expulsion of warm air (with a slightly higher water vapor content) and intake of cool air (with a slightly lower water vapor content) prevents humidity buildup over time, provided that the vent works correctly and that the product is correctly sealed.

Vents become blocked over time as the micropores in the membrane fill with particles. If a vent becomes blocked by dirt – or by water if it has formed a pool over the vent – excess pressure can damage seals or cause air and even water to be sucked into the product along cables. Vents cannot be cleaned and must be replaced if not in perfect condition. Vent replacement intervals depend on the amount of airborne dirt and dust in the installation location. Please contact an authorized Martin service agent for vent replacement.

- Any water that reaches the base of an Exterior Dot-HP™ will normally drain away, so there is normally no risk of water forming a pool on a vent. However, do not install a dot in any way that prevents rainwater, condensation etc. from draining away from the base of the dot.
- Contact an authorized Martin™ service agent for vent replacement if the vent shows signs of contamination or is not in perfect condition.
- Vents must be replaced by an authorized Martin service agent after an extended period of use. Intervals for vent replacement depend on the installation environment.

Exterior Dot-HP™ overview

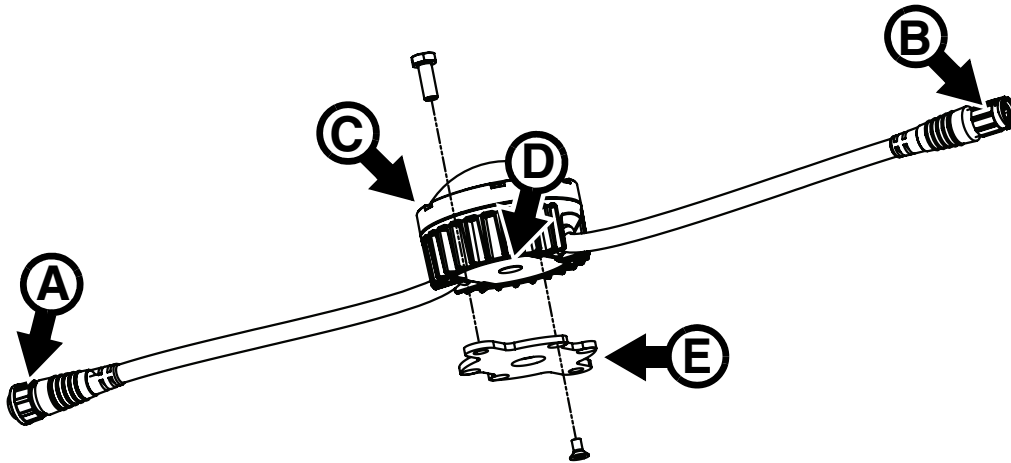

A - DC power + data male BBD-type input connector

C - Dot fixture

B - DC power + data female BBD-type output (thru) connector

D - Pressure relief vent

E - Mounting plate (optional accessory)

Figure 1: Overview

Physical installation



Warning! Read “Safety information” on page 5 before installing the Exterior Dot-HP™ and read all of this ‘Physical installation’ chapter before starting work.

You can install the Exterior Dot-HP™ on a surface or structure using one of two methods:

- You can fasten Exterior Dot-HP™ dots to mounting plates and then fasten the mounting plates to the surface or structure.
- You can fasten Exterior Dot-HP™ mounting profile to a flat surface or structure first and then clip and lock Exterior Dot-HP™ dots onto the mounting profile. This option lets you conceal up to two cable runs inside the profile, giving a clean appearance.

The Exterior Dot-HP™ can be installed in any orientation.

Do not install Exterior Dot-HP™ dots with a cable run longer than 20 m (65 ft.) between any two dots.

Allow free airflow around the product and at least 10 mm (0.4 in.) of clearance around the front surface.

The Exterior Dot-HP™ is designed to withstand water projections such as rainfall and low-pressure water jets and can be installed outdoors, but do not submerge it and do not install it in a location where water can build up around the dot or under the base of the dot. If necessary, provide drainage at the installation location.

Avoiding damage

Avoid causing damage that is not covered by the product warranty by following these instructions carefully.

Keeping connections dry

Moisture on connectors can cause short circuits and damage to products. Check that all connectors are perfectly dry before you connect them. Do not install the Exterior Dot-HP™ during wet weather conditions or if condensation is visible on any surfaces.

Avoiding shocks and stress

Do not expose the Exterior Dot-HP™ to physical shocks (by dropping onto a hard surface, for example).

Do not apply pressure to or otherwise stress diffusers or lenses.

Do not stress cables (by bending them sharply, for example). Protect cables from sharp edges.

Protecting from galvanic corrosion

Dots and profiles are manufactured in marine-grade corrosion-resistant anodized aluminum, but take precautions to avoid direct contact between aluminum and other metals, as this can cause galvanic corrosion:

- Use an electrically insulating material (such as rubber or plastic) or a coating between aluminum dots or mounting profiles and any other metal.
- Use a non-conductive coating such as Delta Seal on fasteners (screws, bolts, washers, etc.) where they come into contact with dots or mounting profiles.

Pressure relief vent

The air inside dots expands and contracts as components warm up and cool down. See Figure 2. To equalize the resulting pressure variations without allowing water into the dot, the Exterior Dot-HP™ features a pressure relief vent (arrowed) with a Gore-Tex membrane.

Do not allow pressure relief vents to become submerged in water or blocked.

If a vent is not in perfect condition, do not operate the dot. Contact Martin™ Service for replacement.

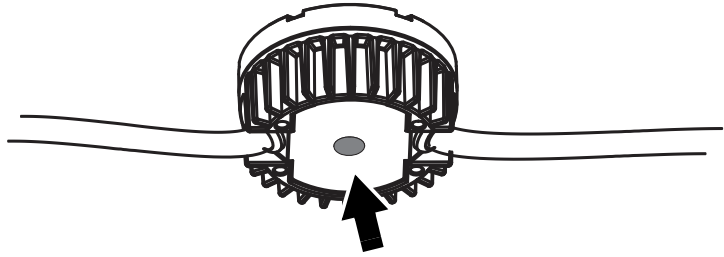

Figure 2: Pressure relief vent

Mounting on a surface or structure

Installing using mounting plates

The mounting plates available from Martin™ as optional accessories for the Exterior Dot-HP™ (see “Accessories” on page 36) are recommended for installation on a flat surface or structure.

All fasteners must be suitable for the application and environment. Steel fasteners must be grade 8.8 minimum. Stainless steel fasteners must be grade 304 (A2) or better,. In marine environments, stainless steel fasteners must be grade 316 (A4) or better.

To install an Exterior Dot-HP™ using a mounting plate:

1. To reduce galvanic corrosion, apply a non-conductive coating such as Delta Seal to all parts of the bolts that will come into contact with the dot.

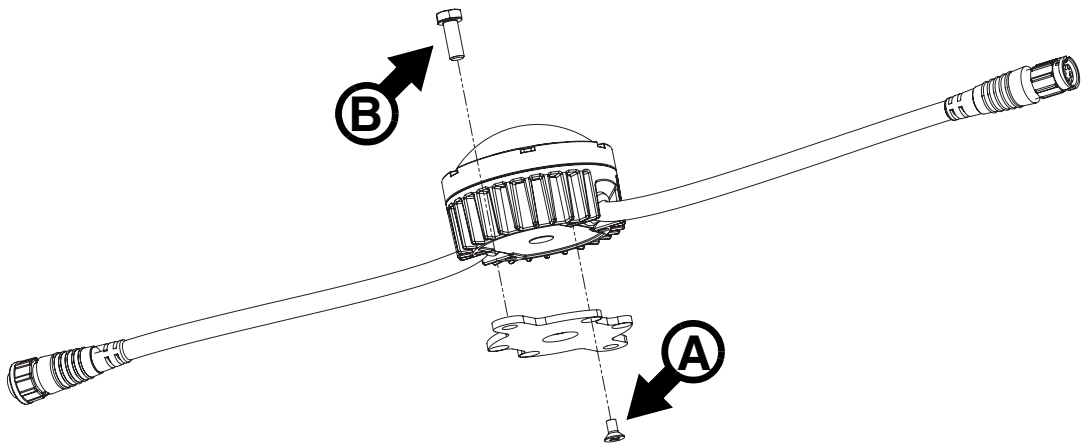

Figure 3: Installing using a mounting plate

2. See illustration above. Fasten the mounting plate to the base of the dot using the four M4 x 8 mm countersunk Torx screws **A** supplied with the mounting plate.
3. For each dot, obtain two grade 8.8 or better M6 (quarter-inch) fasteners (screws, screwbolts, etc.) and screw plugs. You can use M6 machine screws and self-locking nuts if you have access to the back of the installation surface. Check that fasteners are suitable for the application and have appropriate corrosion resistance.
4. With reference to “Dimensions” on page 2 and page 3, prepare two holes with centers 86 mm (3.39 in.) apart in the installation surface to accept two fasteners passed through the holes in the mounting plate. Use screw plugs if necessary to ensure a secure installation.
5. Fasten the Exterior Dot-HP™ and mounting plate assembly securely to the surface using two fasteners **B** per mounting plate.

6. Connect the dot's input connector to the output connector of the previous device on the link, either directly or via a patch cable. Make sure that all connectors are correctly fastened together with locking rings twisted to ensure a seal.
7. Check that the dot is held securely before you leave it.

Installing directly on a surface

It is also possible to install the Exterior Dot-HP™ directly on a surface such as a metal plate if you have access to the back of the surface.

To install an Exterior Dot-HP™ on a surface:

1. Pre-drill the surface with four holes suitably positioned to accept mounting screws.
2. Obtain four M8 machine screws or bolts of a suitable length to pass through the surface and into the dot.
3. Apply a small amount of Loctite to the threads of the screws or bolts, then pass them through the surface and fasten them into the back of the dot.

Installing using mounting profile

To simplify installation on a surface or structure, you can install Exterior Dot-HP™ mounting profiles on the surface and then fasten Exterior Dot-HP™ dots into the profiles. Martin™ supplies mounting profiles as optional accessories in kits (see "Mounting hardware" on page 36). The mounting profile is deep enough to hold two cable runs behind a dot.

See Figure 4. Each mounting profile kit includes:

- Mounting profile **D**
- Lock assembly **E** and locking bolt **F**
- Bracket **B**
- Four screws **C** for fastening brackets to dots.

To install an Exterior Dot-HP™ on a surface using a mounting profile:

1. See Figure 4. Fasten each dot **A** to a mounting profile bracket **B** using the four screws **C** supplied.
2. For each mounting profile, obtain two grade 8.8 or better M6 (quarter-inch) fasteners (screws, screwbolts, etc.) and screw plugs. Check that fasteners are suitable for the application and have appropriate corrosion resistance. Apply an electrically insulating coating such as Delta Seal to fasteners to prevent contact between the aluminum profile and the fasteners. If necessary, use electrically insulating material to prevent contact between the aluminum profile and any other metals when the profile is installed.
3. With reference to the mounting profile dimensions drawing on page 3, prepare two holes with centers 20 mm (0.55 in.) apart to accept the fasteners for each mounting profile. Use screw plugs if necessary for a secure installation.

4. Fasten each mounting profile **D** securely to the surface or structure using two fasteners per profile.

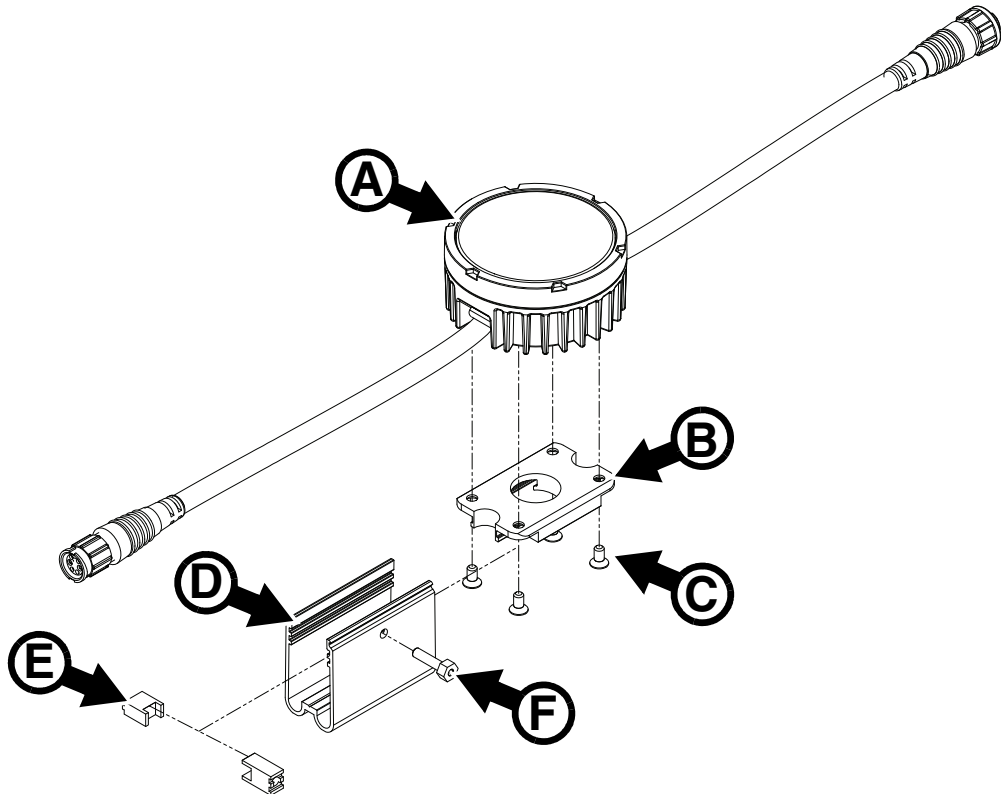

Figure 4: Installation with a mounting profile

5. If you are going to install the dot now, apply a small quantity of Loctite 243 to the threads of the locking bolt **F** (if you are going to install the dot in the profile later, apply the Loctite when you install the dot). With the two halves of a lock **E** assembled as shown in Figure 4 and located in the grooves in the mounting profile, tighten the bolt **F** through the mounting profile and into the lock finger-tight only.
6. Connect the dot's input connector to the output connector of the previous device on the link, either directly or via a patch cable. Make sure that all connectors are correctly fastened together with locking rings twisted to ensure a seal.
7. See Figure 5. Clip the dot onto the mounting profile so that the lips on the mounting bracket engage in the channels on both sides of the profile as shown at **G**.
8. Tighten the locking bolt **F** to secure the dot in the profile. The bolt accepts a 2.5 mm Allen key or a 7 mm wrench. Tighten the bolt to a torque of 1 Nm (0.75 ft.-lbs.) using a torque driver or torque wrench. When you have tightened the bolt, check that the head of the bolt sits flat against the mounting profile.
9. Check that the dot is held securely before you leave it.

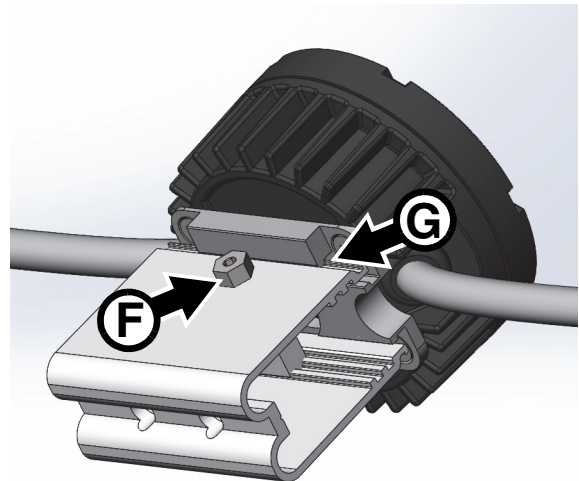

Figure 5: Installing a dot on a mounting profile

System installation



Warning! Read “Safety information” on page 5 and “Precautions to avoid damage” on page 11 carefully before installing an Exterior Dot-HP™ system.

Warning! Connect the Exterior Dot-HP™ only to the devices and using only the Martin™ cables specified in this manual.

Warning! Do not exceed the maximum numbers of devices that can be connected in chains and maximum cable lengths specified in “Protection from electric shock” starting on page 6 and in the manuals of the other devices in the system.

Important! If using DMX, make sure that the DMX console and DC power source are at the same earth (ground) potential, or the data signal may become saturated.

The Exterior Dot-HP™ is designed to display either Martin P3™ video or DMX-controlled lighting effects. It automatically recognizes and responds to either a Martin P3™ or a DMX data signal. The next sections explain how to create an Exterior Dot-HP™ installation to display P3 video data or DMX-controlled lighting effects.

Installing a P3 system

See Figure 7 for an overview of the elements and layout of a Martin P3™ video display system.

To install a system that displays P3 video on Exterior Dot-HP™ dots, see the overview in Figure 7 and follow these directions:

1. Make sure that no devices in the installation can be connected to AC mains power until all installation work is complete.
2. Read “Safety information” on page 5 and “Precautions to avoid damage” on page 11.
3. Connect Exterior Dot-HP™ dots together in chains either directly using the dots’ cable tails and BBD connectors or by adding Martin™ hybrid cables with BBD connectors (see “Cables” on page 36).

Warning! Do not exceed the maximum number of dots per chain given in “Safety limits for connecting devices” on page 6.

4. Install a blanking cap (see “Connectors” on page 37) on the output connector of the last dot on each chain to protect from water, dirt etc.
5. Connect each chain of Exterior Dot-HP™ dots to one of the four 4-pin female XLR hybrid (48 VDC power + P3 data) outputs on a P3 PowerPort 1500™ using a Martin™ hybrid 4-pin male XLR to BBD adapter cable, P/N 11840257 (see Figure 6). Alternatively, connect each chain of Exterior Dot-HP™ dots to one of the 4 outputs on a P3 PowerPort 1000 IP™.

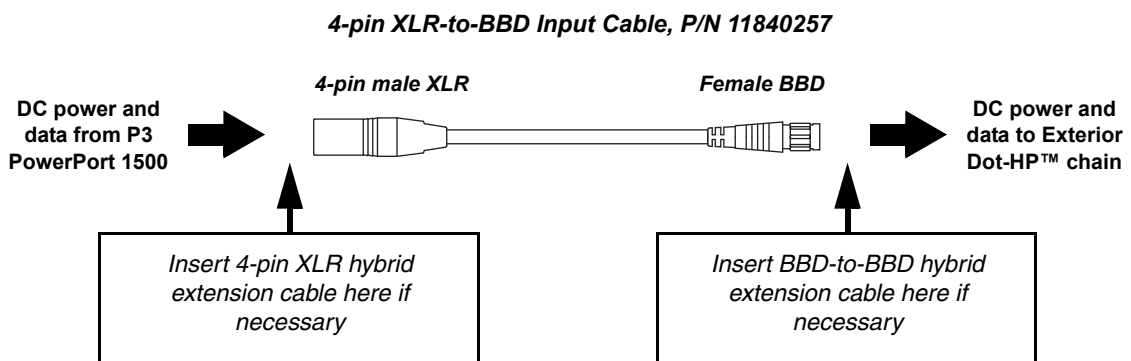
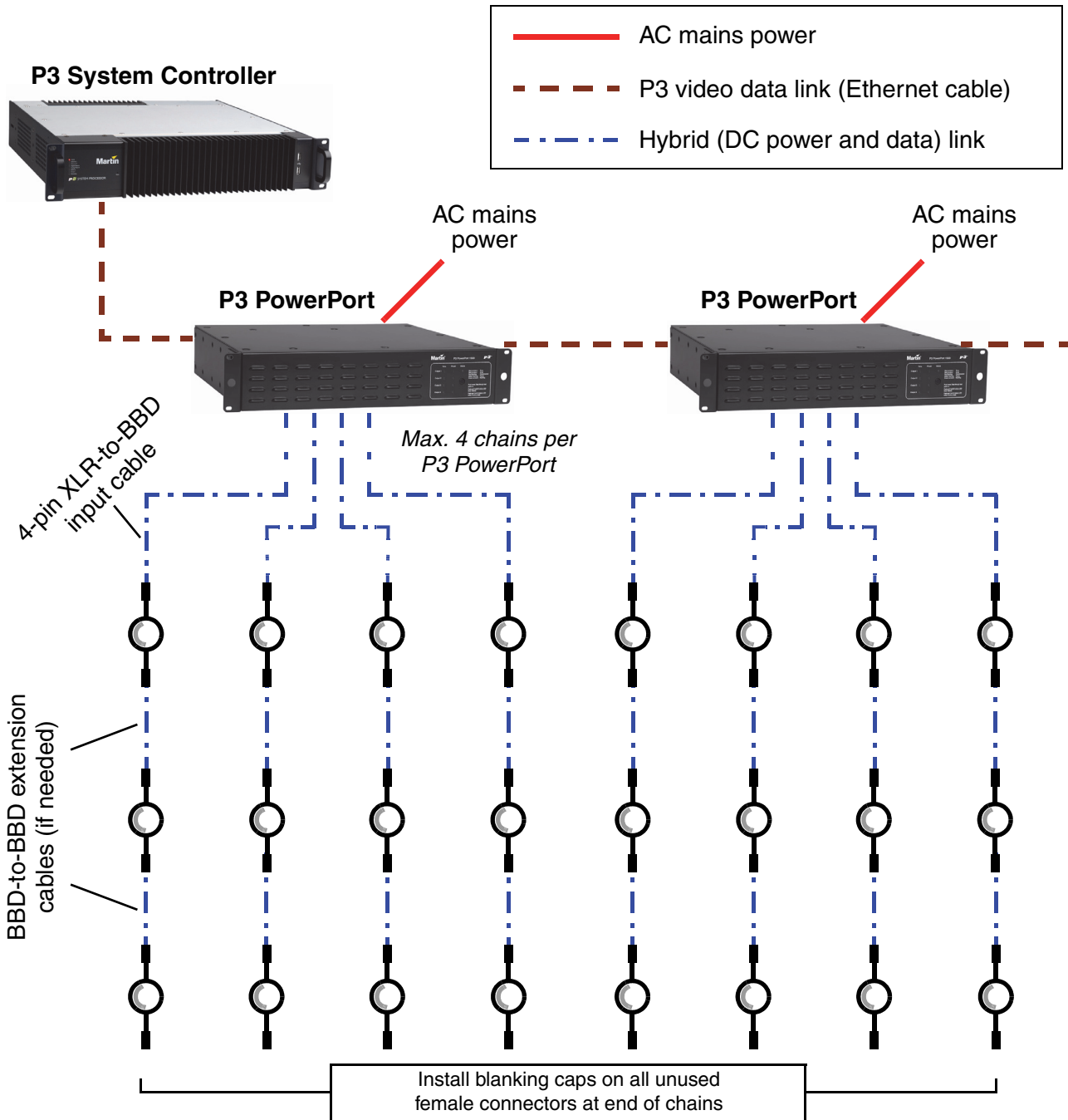

Figure 6: Power and P3 video data input

6. If necessary, add a BBD-to-BBD extension cable between the first dot and the P3 PowerPort. Suitable extension cables are available from Martin™ in various lengths. See “Cables” on page 36.
7. Create a P3 video data link from a Martin P3™ system controller such as the P3-100™, P3-200™, P3-300™ or P3 PC™ to the P3 PowerPort 1500™ or P3 PowerPort 1000 IP™ (see the products’ user manuals for details).

8. It is possible to connect P3 PowerPort devices in daisy-chains in a P3 network, but if you are using multiple P3 PowerPorts in a fixed installation we recommend that you distribute the P3 signal by connecting an unmanaged Gigabit Ethernet switch to the P3 System Controller and then connecting each P3 PowerPort directly to the switch. This eliminates the risk of one P3 PowerPort signal failing and causing loss of signal to the P3 PowerPorts daisy-chained behind it.
 9. Connect the P3 PowerPort to AC mains power at 100 - 240 V, 50/60 Hz as described in its user manual.
 10. connect the P3 system controller to AC mains power and power the controller on.
- You can now configure the system at the P3 controller. See "System setup" on page 24.



 See "Safety limits for connecting devices" on page 6 before creating a chain

Figure 7: P3 system layout

Installing a DMX-controlled system

In a DMX-controlled system, an RDM-compliant DMX lighting controller sends a DMX control data signal over a DMX link to the installation, and then over the hybrid link to the Exterior Dot-HP™ dots.

The DMX link requires DMX cable. It can be maximum 300 m (1000 ft.) in length and must run in one single daisy-chain, but it can be extended or split into branches using an RDM-compliant amplifier/splitter such as the Martin RDM 5.5 Splitter™ (P/N 90758150). Alternatively, you can run the DMX signal from the controller over Ethernet cable using Art-Net protocol and convert it to a DMX-compliant signal with an Art-Net to DMX converter.

If you would like assistance with creating a DMX link, your Martin™ supplier will be glad to advise.

The number of Exterior Dot-HP™ dots that you can control on one DMX link is limited by the number of DMX channels the dots will use and the 512 DMX channels available in one DMX universe at the DMX controller. Each time you have used 512 channels, you must create a new DMX link that is connected to a new DMX universe on the controller. Note that this limit applies to the *DMX link*. The maximum safety limits that apply to the chain of dots and cable (see “Safety limits for connecting devices” on page 6) take priority and must be respected in all cases.

If you need to take the DMX signal from the end of a chain of Exterior Dot-HP™ dots, connect a DMX Lead-out Cable (see “Cables” on page 36) to the output connector of the last dot on the chain. The Lead-Out Cable has a 5-pin female XLR connector with standard DMX pinout (pin 1 = shield, pin 2 = data cold/negative, pin 3 = data hot/positive, pins 4 and 5 are not used) that lets you draw off the DMX signal.

DC Power options in DMX installations

A DMX-controlled Exterior Dot-HP™ installation can be supplied with DC power from the Martin™ IP66 Power Supply Unit or from a generic external PSU (the Mean Well SP-480 48, for example).

The hardware and cables required are slightly different depending on which type of PSU you use to supply the installation with DC power. The two different types of installation are covered in the next two sections:

- If you are using a Martin™ IP66 PSU, see “Installing a DMX system using the Martin™ IP66 PSU” on page 20.
- If you are using a generic 48 VDC PSU, see “Installing a DMX system using a generic external 48 VDC PSU” on page 22.

Installing a DMX system using the Martin™ IP66 PSU

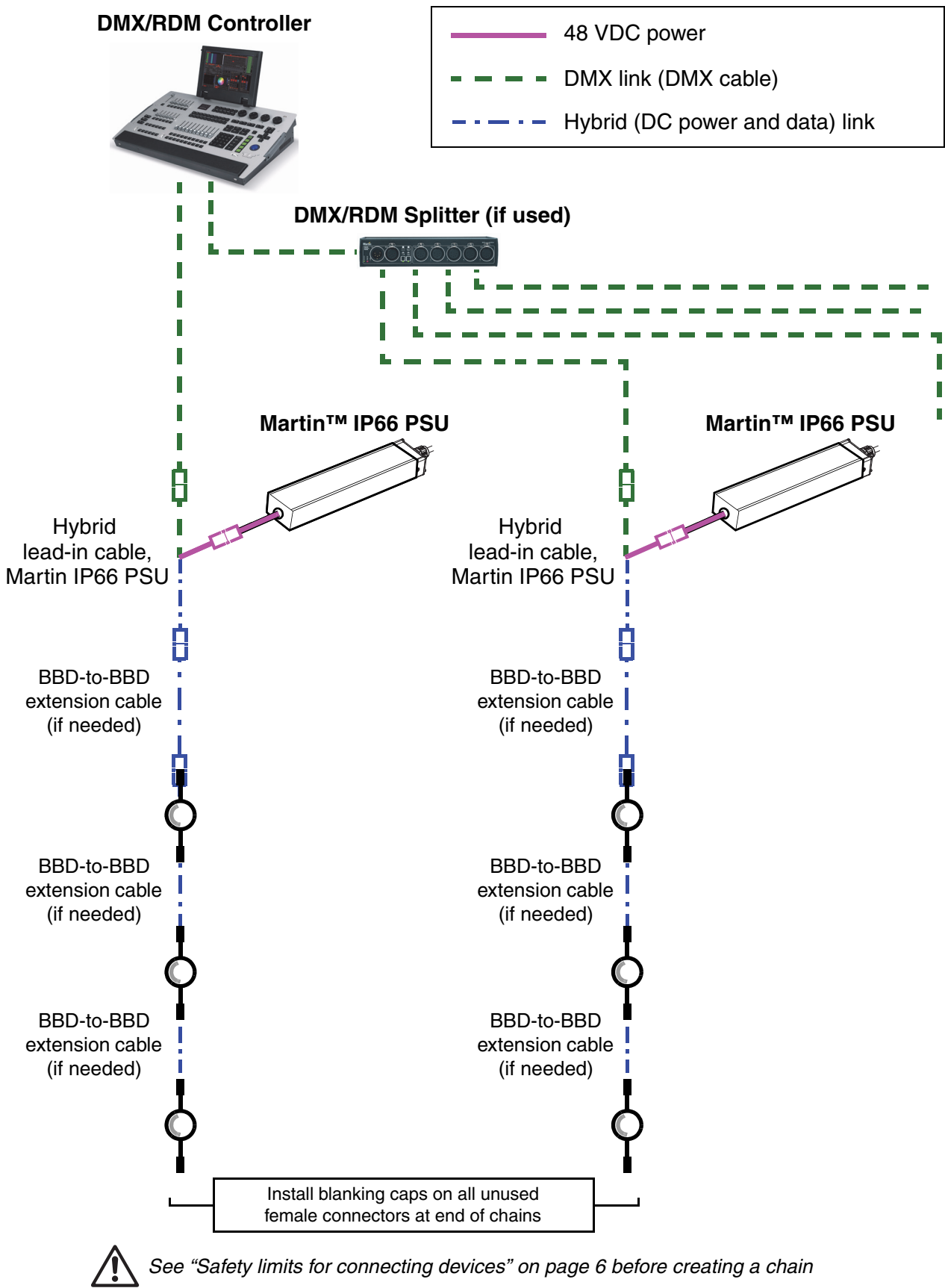

Figure 8: DMX-controlled system using the Martin™ IP66 Power Supply Unit

To create a DMX-controlled installation that draws DC power from the Martin™ IP66 PSU:

1. See Figure 8 on page 20 for an overview of this type of installation
2. Make sure that no devices in the installation can be connected to AC mains power until all installation work is complete.
3. Read “Safety information” on page 5 and “Precautions to avoid damage” on page 11.
4. Connect Exterior Dot-HP™ dots together in chains either directly using the BBD connectors on the dots’ cable tails or by adding Martin™ hybrid BBD-to-BBD extension cables (see “Cables” on page 36).
Warning! Do not exceed the maximum number of dots per chain given in “Martin™ IP66 PSU 240W safety limits” on page 8.
5. Install a blanking cap (see “Connectors” on page 37) on the output connector of the last dot on each chain to protect from water, dirt etc. There is no need to install DMX termination plugs, as dots have integral DMX termination.
6. See Figure 9. Connect a Martin™ 5-pin XLR and Martin™ IP66 PSU to BBD adapter cable (P/N 11840275) to the start of each chain.
 - Connect the 5-pin male XLR connector on the adapter cable to a DMX link that carries a DMX signal from an RDM-compliant DMX controller such as the Martin M-PC™.
 - Connect the male Martin™ IP66 PSU connector on the adapter cable to the DC output of a Martin™ IP66 Power Supply Unit.
 - Connect the female BBD connector on the adapter cable to the male BBD connector at the start of the chain of Exterior Dot-HP™ dots.

XLR5+Martin™ IP66 PSU-to-BBD Input Cable, 0.25 m, P/N 11840275

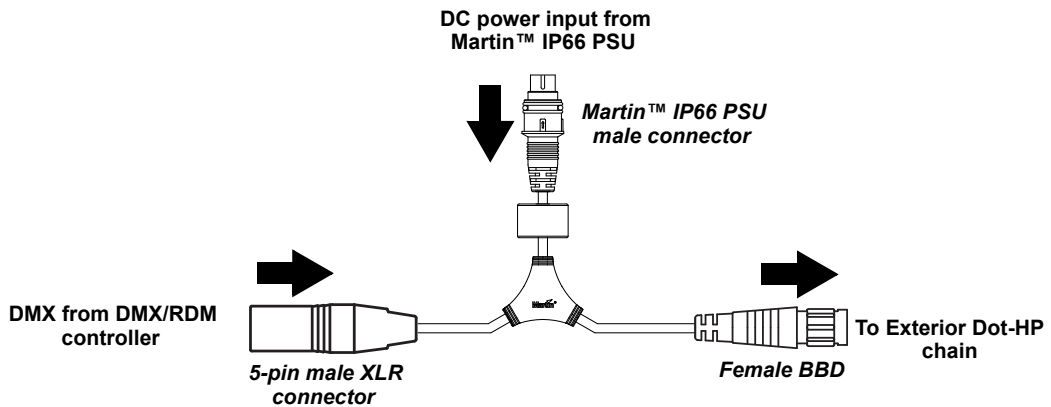
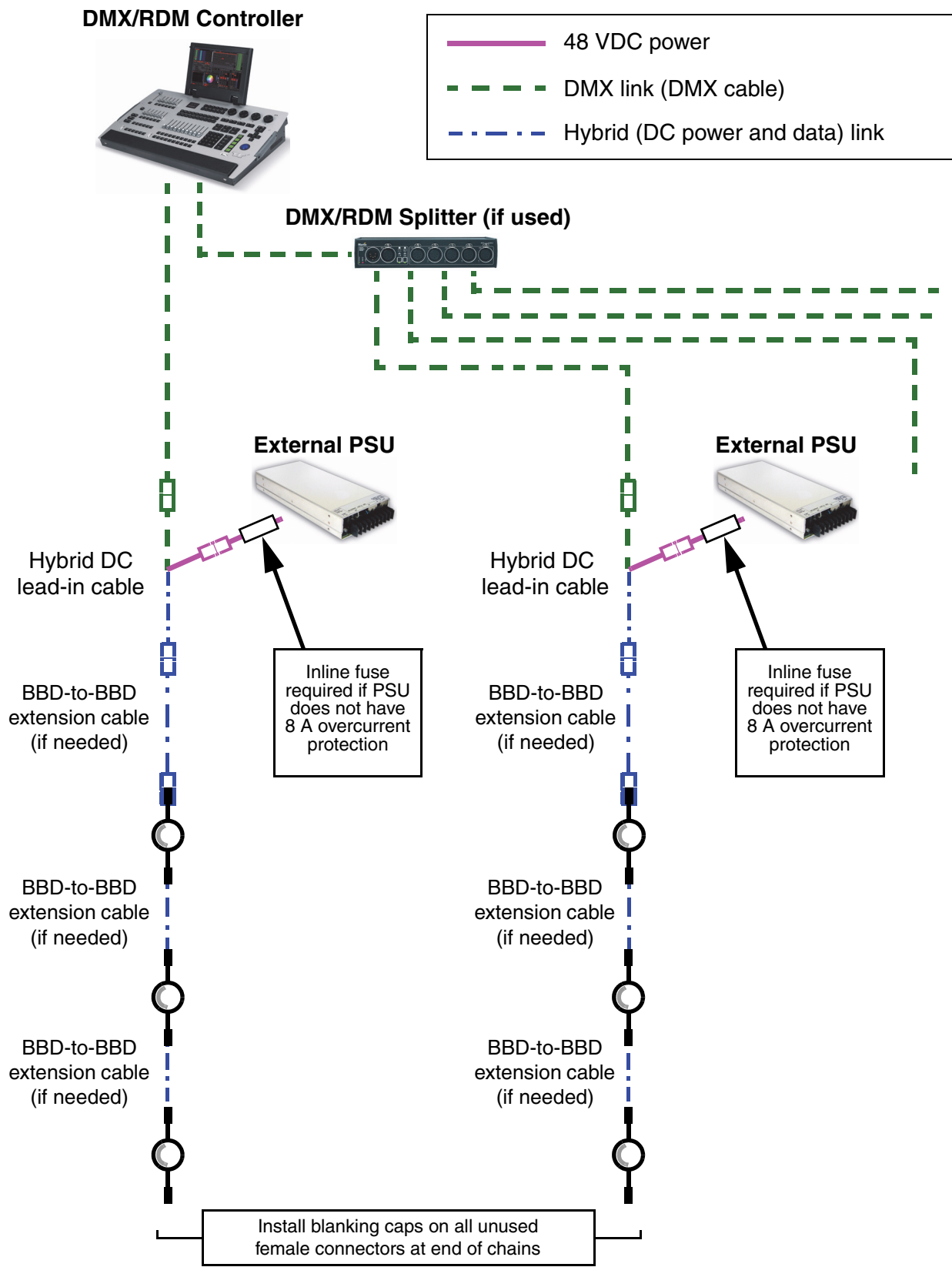

Figure 9: Martin™ IP66 PSU and DMX connections to an Exterior Dot-HP™ chain

7. Install a mains power cable on the Martin™ IP66 Power Supply Unit and connect it to AC mains power.
 8. Apply AC mains power to the DMX controller.
- You can now configure the system. See “System setup” on page 24.

Installing a DMX system using a generic external 48 VDC PSU



See "Safety limits for connecting devices" on page 6 before creating a chain. Do not exceed PSU output rating.

Figure 10: DMX-controlled system using a generic PSU

Warning! If you decide to use any other external PSU than the Martin™ devices listed earlier in this section, you must verify that the combination of equipment used is compliant with all applicable safety and electromagnetic compatibility regulations.

To create a DMX-controlled installation that draws DC power from a generic PSU:

1. See Figure 10 on page 22 for an overview of this type of installation.
2. Make sure that no devices in the installation can be connected to AC mains power until all installation work is complete.
3. Read "Safety information" starting on page 5 and "Precautions to avoid damage" on page 11.
4. Connect Exterior Dot-HP™ dots together in chains either directly using the BBD connectors on the dots' cable tails or by adding Martin™ BBD-to-BBD hybrid extension cables (see "Cables" on page 36).

Warning! Check the PSU's DC output power rating in watts and the power consumption figures in watts for Exterior Dot-HP™ dots with reference to "Generic 48 VDC external PSU safety limits" on page 8. Do not create a chain of Exterior Dot-HP™ dots that will exceed the power rating of the DC output on the PSU.

5. Install a blanking cap (see "Connectors" on page 37) on the output connector of the last dot on each chain to protect from water, dirt etc.
6. See Figure 11:
 - If the PSU does not have constant overcurrent protection that will limit current to 8 A on the DC output used, install an inline fuseholder with a 7.5 A fuse on the white (+ve) power wire of a Martin™ Power and data adapter cable, XLR5 + power - BBD, 0.25 m (P/N 11840276). You can use a 30 amp automotive-type inline fuseholder with a 7.5 A blade fuse.
 - Connect the 5-pin male XLR connector on the power and data adapter cable to a DMX link that carries a DMX signal from an RDM-compliant DMX controller such as the Martin M1™ or M-PC™.
 - Connect the power wires on the power and data adapter cable to a DC output on the PSU. Connect the white wire to positive (+ve) and the black wire to negative (-ve).
 - Connect the female BBD connector on the adapter cable to the male BBD connector at the start of the chain of Exterior Dot-HP™ dots.

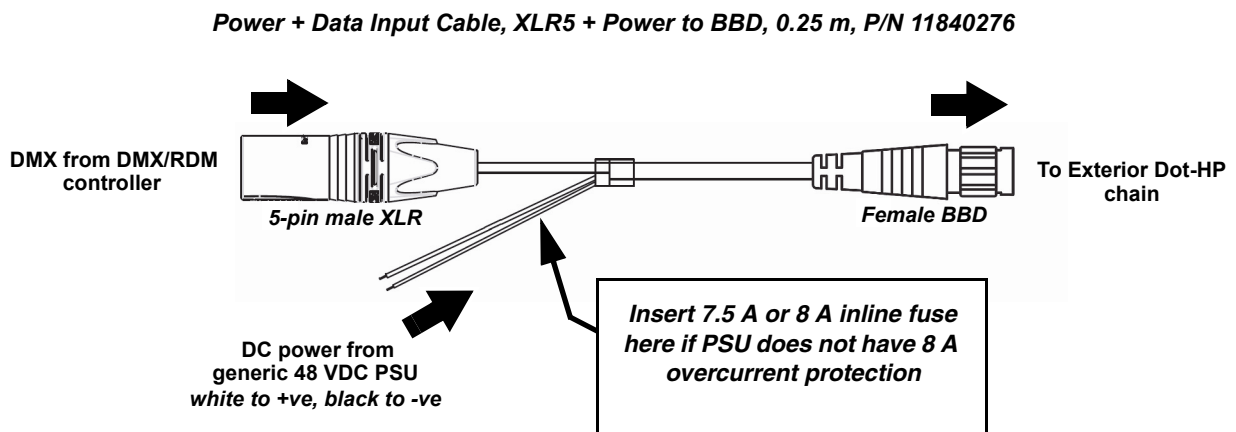

Figure 11: Generic PSU and DMX connections to an Exterior Dot-HP™ chain

7. Apply AC mains power to the external PSU.
8. Apply AC mains power to the DMX controller.

You can now configure the system. See "System setup" on page 24.

System setup



Warning! Read “*Safety information*” on page 5 and “*Precautions to avoid damage*” on page 11 before applying power to an Exterior Dot-HP™ installation.

Setting up for P3 display

A Martin P3™ system allows video to be displayed on an installation that consists of or includes Exterior Dot-HP™ dots. When a P3 controller is connected to the data link and the installation is powered on, you can set up all the devices on the link from the P3 controller. See the P3 controller user manual for details.

Setting up for DMX control

A DMX system gives 0 - 100% variable intensity control. Varying the intensity of red, blue and green LEDs in RGB products gives RGB color mixing.

You can set up and control an Exterior Dot-HP™ installation over the data link using an RDM-compatible DMX controller such as the Martin M-PC™ Windows application (running on a PC connected to a USB/DMX interface such as the Martin M-DMX Interface Box) the Martin M1™ DMX/RDM control console. The interface on the Martin M1™ monitor screen is basically identical to the Martin M-PC™ interface.

DMX control channels

DMX controllers send control data to devices over DMX control channels in DMX universes. One DMX universe has 512 channels available. Multiple dots can share the same DMX channels if you want grouped control and identical dot behavior.

The Exterior Dot-HP™ can be controlled using two DMX modes (see under “DMX protocols” on page 33):

- In RGB mode, each dot uses three DMX channels.
- In Basic mode, each dot uses ten DMX channels.

Different modes can be mixed freely in an installation. For example, some Exterior Dot-HP™ dots can be set to RGB mode and others to Basic mode. All you need to do is set up dots, DMX addresses and DMX channel allocation correctly.

DMX addresses

To prepare an installation for DMX control, you set it up using an RDM-compliant DMX controller so that dots or pixels receive instructions from the controller on their own DMX channels. The DMX address (also known as the control address or start channel) is the first of these channels. An Exterior Dot-HP™ dot or pixel uses more than one channel, so it uses the DMX address channel and the channels immediately above it. For example, one Exterior Dot-HP™ dot set to RGB mode and set to DMX address 1 will use DMX channels 1 - 3. Channel 4 will be available for use as a DMX address for the next device.

RDM

Using an RDM-compliant DMX controller such as Martin M-PC™, you can communicate with the Exterior Dot-HP™ dots on the DMX data link via RDM. You can:

- Retrieve data from dots
- Set the DMX addresses of the dots and set their DMX mode
- Reset dots

To use Martin M-PC, connect a PC running this application to the data link using the Martin M-DMX USB/DMX interface box.

The Exterior Dot-HP™ responds to the RDM parameter IDs listed in Table 5.

RDM parameter IDs	GET allowed	SET allowed
Category – Network Management		
DISC_UNIQUE_BRANCH		
DISC_MUTE		
DISC_UN_MUTE		
Category - Product Information		
DEVICE_INFO	✓	
DEVICE_MODEL_DESCRIPTION	✓	
MANUFACTURER_LABEL	✓	
DEVICE_LABEL	✓	✓
SOFTWARE_VERSION_LABEL	✓	
Category - DMX512 Setup		
DMX_PERSONALITY	✓	✓
DMX_PERSONALITY_DESCRIPTION	✓	
DMX_START_ADDRESS	✓	✓
SLOT_DESCRIPTION	✓	
Category - Control		
IDENTIFY_DEVICE	✓	✓
RESET_DEVICE		✓

Table 5: RDM communication with the Exterior Dot-HP™

Using the Exterior Dot-HP™



Warning! Read “Safety information” on page 5 and “Precautions to avoid damage” on page 11 on before applying power to the Exterior Dot-HP™.

Do not use the Exterior Dot-HP™ if the ambient temperature exceeds 55° C (131° F) or falls below -20° C (-4° F).

Thermal regulation

The Exterior Dot-HP™ dot has a protective thermal shutdown feature that blacks out the dot if it exceeds its permitted maximum operating temperature.

To avoid unexpected blackouts due to thermal shutdowns but also avoid overheating that may damage the product, the Exterior Dot-HP™ offers various options for managing temperature:

- During P3 video operation, you can enable the thermal regulation feature available in the software of all Martin P3 system controllers. When this feature is active, Exterior Dot-HP™ dots begin to reduce their light output when the ambient temperature reaches 45° C in order to control dot temperature. Output is reduced gradually as the ambient temperature rises above 45° C. Dots will still light at the maximum ambient temperature of 55° C, but output will be considerably reduced. This option avoids blackouts due to protective thermal shutdowns.
- During P3 video operation, you can disable the P3 controller thermal regulation feature. If you choose to do this, Exterior Dot-HP™ dots will not reduce their light output when the ambient temperature reaches 45° C, but if you drive dots hard when the ambient temperature approaches or exceeds 55° C, dots may black out completely due to protective thermal shutdown.
- During DMX operation, the Exterior Dot-HP™ dots begin to reduce their light output when the ambient temperature reaches 45° C in order to control dot temperature. Output is reduced gradually as the ambient temperature rises above 45° C. Dots will still light at the maximum ambient temperature of 55° C, but output will be considerably reduced. This option avoids blackouts due to protective thermal shutdowns.

P3 display

The Exterior Dot-HP™ can display video from all common video sources. The video signal must be sent to a Martin P3™ controller and then distributed to dots. The P3™ controller lets you map, configure and control an installation containing Exterior Dot-HP™ dots (and other Martin P3™ video display products if you have them). See the P3 controller documentation for details.

DMX control

The Exterior Dot-HP™ can display effects controlled by DMX. Three DMX modes are available:

- **RGB mode** uses three DMX channels and gives RGB color mixing of all the pixels on a dot.
- **Basic mode** uses ten DMX channels and gives RGB color mixing, strobe effects and pre-programmed dynamic effects.

See “DMX protocols” on page 33 for full details of DMX control.

An RDM-compatible DMX controller is required so that you can address and configure the dots. See the DMX/RDM controller documentation for details.

Magnetic ‘control button’

A magnetic sensor is embedded inside the Exterior Dot-HP™ behind the label on the back of the dot (see **C** in Figure 1 on page 12). The sensor acts as a control button. To activate the sensor, swipe a magnet past the side of the dot near where the input cable tail enters the dot.

You may find it convenient to use the Martin Test Tool (see “Accessories” on page 36), which contains a magnet.

Activating the magnetic sensor lets you display the product’s status, test the LEDs and reset the Exterior Dot-HP™ as explained in the following table.



Figure 12: Test Tool with magnet

Status display

To display a Exterior Dot-HP™ dot’s status, swipe the magnet over the sensor once. The LEDs on the dot will give one of the indications listed in the tables below for a few seconds.

Exterior Dot-HP™ RGB

Color	Output	Indication	Action required
Blue	Constant	Busy (e.g. booting up or writing to flash memory).	Wait a moment for normal operation to be resumed.
Red	Constant	Error. The Exterior Dot-HP™ has encountered a fatal error and can not run.	Perform a factory reboot, followed by a firmware upload if necessary.
Red	Flashing	No control source detected.	Connect a P3 system controller or DMX controller to the network.
Green	Flashing	Ready. Exterior Dot-HP™ connected to P3 controller but not mapped onto the canvas.	Set up the P3 controller to use the Exterior Dot-HP™.
Green	Constant	Running normally in P3 mode.	None.
Cyan	Flashing	Ready. Exterior Dot-HP™ in DMX mode but not receiving valid DMX data signal.	Send DMX data (if flashing cyan continues although you are sending data, check that DMX controller is connected and configured with dot’s DMX address).
Cyan	Constant	Running normally in DMX mode.	None.

Table 6: Status information, Exterior Dot-HP™ RGB

Exterior Dot-HP™ CW

No. of LEDs	Output	Indication	Action required
1	Constant	Error. The Exterior Dot-HP™ has encountered a fatal error and can not run.	Perform a factory reboot, followed by a firmware upload if necessary.
1	Flashing	No control source detected.	Connect a P3 system controller or DMX controller to the network.
2	Constant	Running normally in P3 mode.	None.
2	Flashing	Ready. Exterior Dot-HP™ connected to P3 controller but not mapped onto the canvas.	Set up the P3 controller to use the Exterior Dot-HP™.
3	Constant	Running normally in DMX mode.	None.
3	Flashing	Ready. Exterior Dot-HP™ in DMX mode but not receiving valid DMX data signal.	Send DMX data (if flashing continues although you are sending data, check that DMX controller is connected and configured with dot's DMX address).
4	Constant	Busy (e.g. booting up or writing to flash memory)	None.

Table 7: Status information, Exterior Dot-HP™ CW

Testing, rebooting and returning to defaults

The tables below list the functions of the magnetic 'control button' on each Exterior Dot-HP™ dot.

Test patterns are stored in onboard memory. This lets you test the LEDs without an external controller, but test patterns can also be called up on P3 system controllers, the P3 PowerPort 1500™ and the P3 PowerPort 1000 IP™.

Exterior Dot-HP™ RGB

Action	Function
Quick swipe	The first swipe displays status as shown in Table 6 for a few seconds. The next swipes display the following test patterns on the LEDs (each swipe scrolls to the next pattern): <ul style="list-style-type: none">- Calibrated white- Full red- Full green- Full blue- Scrolling gradient- Dimmed (20% uncalibrated white)
Hold magnet over 'button' until LEDs light blue	Reboot the Exterior Dot-HP™.
Hold magnet over 'button' until LEDs light white	Return the Exterior Dot-HP™ to its default factory firmware.

Table 8: Magnetic 'control button' functions, Exterior Dot-HP™ RGB

Exterior Dot-HP™ CW

Action	Function
Quick swipe	The first swipe displays status as shown in Table 6 for a few seconds. The next swipes display the following test patterns on the LEDs (each swipe scrolls to the next pattern): <ul style="list-style-type: none">- Calibrated white- Full red- Full green- Full blue- Scrolling gradient- Dimmed (20% uncalibrated white)
Hold magnet over 'button' until 4 LEDs light	Reboot the Exterior Dot-HP™.
Hold magnet over 'button' until 3 LEDs light	Return the Exterior Dot-HP™ to its default factory firmware.

Table 9: Magnetic 'control button' functions, Exterior Dot-HP™ CW

Service and maintenance



Warning! Read “Safety information” on page 5 and “Precautions to avoid damage” on page 11 before carrying out service on the Exterior Dot-HP™.

Warning! Lock out AC mains power to the installation before servicing.

Warning! Refer any service operation not described in this manual to a qualified service technician.

Important! Excessive dirt buildup causes overheating and may damage the product. Damage caused by inadequate cleaning is not covered by the product warranty.

The user will need to clean the Exterior Dot-HP™ periodically. All other service operations on the Exterior Dot-HP™ must be carried out by Martin Professional™ or its approved service agents.

Installation, on-site service and maintenance can be provided worldwide by the Martin Professional Global Service organization and its approved agents, giving owners access to Martin's expertise and product knowledge in a partnership that will ensure the highest level of performance throughout the product's lifetime. Please contact your Martin supplier for details.

Cleaning

Cleaning schedules vary depending on the operating environment. It is therefore impossible to specify precise cleaning intervals for the Exterior Dot-HP™. Environmental factors that may result in a need for frequent cleaning include airborne dust and pollution.

Inspect products frequently to see whether cleaning is necessary. If in doubt, consult your Martin™ dealer about a suitable maintenance schedule.

To clean the product, use warm water and a soft brush or a low-pressure or medium-pressure water jet. Use car shampoo to help remove dirt and grease. If possible, dry with a soft cloth to avoid streaking. Do not use a stiff brush or scouring pad. Do not use solvents or abrasives.

Condensation and pressure relief valve

Under certain conditions, condensation may become visible under optical components. This is normal and harmless. Any condensation will gradually be expelled by the dot's Gore-Tex pressure relief valve (see Figure 2 on page 14) as the dot goes through power off/on cycles.

Make sure that the pressure relief valve is clean and unblocked. The valve must be able to breathe freely so that it can equalize pressure and expel water vapor. If a valve becomes blocked, excessive pressure can damage seals or cause air and water to be sucked along cables and into the dot.

Water on the valve membrane will block the membrane's micropores. Do not allow water to collect on or near valves. If you suspect that a valve has become blocked with dirt, contact your Martin supplier.

LED performance

Martin™ use the best components available, but the characteristics of all LEDs change gradually over many thousands of hours of use. Not all colors change at the same rate, and rates of change vary depending on factors such as temperature and how intensively a particular color is used. Because of the changes, overall light output and the exact hues obtained from specific color mixes in all LED-based products can be expected to shift slightly over time.

To help you obtain consistent output despite these changes, Martin™ P3 software from version 4.1.0 contains the P3 Dot Adjuster tool. This feature lets you compensate for changes in LED characteristics and restore initial output and color authenticity levels. Please contact Martin™ for more details.

Installing new software

It may be necessary to upload new software (i.e. device firmware) to the Exterior Dot-HP™ if it appears to have a software-related fault or if you want to update to a newer software version.

Software for Martin™ products is available from the Martin™ website. The Exterior Dot-HP™ software can be installed from the P3 System Controller over the P3 data link. You will need a Martin P3 PowerPort 1500™ or a Martin P3 PowerPort 1000 IP™ for this. See the P3 System Controller user manual for software installation instructions.

Troubleshooting

Problem	Probable cause(s)	Remedy
Control is lost and activating magnetic 'control button' causes Exterior Dot-HP™ to show constant or flashing red status indication.	Error has occurred.	Check that system is correctly connected, set up and running. Hold magnet over 'control button' until LEDs 1 - 4 turn blue, then move magnet away, to reboot Exterior Dot-HP™. Restart P3 or DMX controller.
Product seems completely dead.	Product has gone into thermal protection shutdown.	Check product temperature readouts on P3 system controller. Reduce ambient temperature by providing ventilation or fan cooling, for example.
	No DC power to product.	Check 48 VDC power supply and cables
	Internal fault.	Disconnect from power. Do not attempt repairs yourself. Contact Martin™ Service or an authorized Martin™ service partner for assistance.
Exterior Dot-HP™ does not display as intended.	Fault in 48 VDC power transmission.	Inspect connections and cables. Correct poor connections. Repair or replace damaged cables.
	Fault in data transmission.	Inspect connections and cables. Correct poor connections. Repair or replace damaged cables. If using DMX, check that DMX console and DC power supply unit are at same earth (ground) potential.
	Incorrect mapping or addressing of products.	Check product address and controller settings.
	Product in installation is defective and is disturbing data transmission.	Substitute known good products one at a time until normal operation is regained. Have faulty product serviced by Martin™ Service.

Table 10: Troubleshooting

DMX protocols

RGB Mode

Channel	DMX Value	Function
1	0 - 255	Red 0 → 100%
2	0 - 255	Green 0 → 100%
3	0 - 255	Blue 0 → 100%

Table 11: DMX Protocol, RGB Mode

Basic Mode

Channel	DMX Value	Function
1	0 - 65535	Dimmer fade (MSB) 8-bit coarse control, closed 0% → open 100%
2		Dimmer fade (LSB) 16-bit fine adjustment, closed → open
3	0 - 49 50 - 200 201 - 210 211 - 255	Strobe No strobe Strobe, slow → fast No strobe Random strobe, slow → fast
4	0 - 255	Strobe duration 0 → 1 second
5	0 - 7 8 - 255	FX selection No FX: output controlled on RGB channels FX selection (see “Pre-programmed FX” on page 34)
6	0 - 126 127 - 128 129 - 255	FX speed / modifier (depending on effect) Fast → slow Stop Slow → fast
7	0 1 2 3 - 34 35 36 37 - 100 101 - 120 121 - 140 141 - 255	FX synchronization No sync Dot offset 10° Dot offset 10° ... Dot offset 350° Synchronized <i>No function (reserved for future use)</i> Random start Random duration <i>No function (reserved for future use)</i>
8	0 - 255	Red 0 → 100%
9	0 - 255	Green 0 → 100%
10	0 - 255	Blue 0 → 100%

Table 12: DMX Protocol, Basic Mode

Pre-programmed FX

Select the FX in this table on channel 5 in Basic Mode.

Set FX execution speed on channel 6.

Synchronize and set offsets between dots on channel 7.

Channel	DMX Value	Function	
5	0	No FX	
		Intensity FX	
	1	Wave	
	2	Step	
	3	Pulse	
	4	Blackout strobe	
	5	2x strobe	
	6	3x strobe	
	7	4x strobe	
	8	Up, down flash	
	9	Up, flash, down, flash	
	10	Random levels	
	11	Pixel killer	
	12	Noise overlay	
	13 - 19	<i>No function (reserved for future use)</i>	
	20	Movie flicker	
	21	Electric arc	
	22	Atomic lightning	
	23	Thunderstorm	
	24 - 50	<i>No function (reserved for future use)</i>	
		Color FX	
	51	Rainbow wave	
	52	Rainbow step	
	53	Rainbow pulse	
	54	RGB wave	
	55	RGB step	
	56	RGB pulse	
	57	CMY wave	
	58	CMY step	
	59	CMY pulse	
	60	Random mix wave	
	61	Random mix step	
	62	Random mix pulse	
	63 - 68	<i>No function (reserved for future use)</i>	
	69	Solid	
	70	Spectrum shifter	
	71	RGB to white wave	
	72	RGB to white step	
	73	RGB to white pulse	
	74	RGB to white strobe	
	75	Normal to white wave	
	76	Normal to white step	
	77	Normal to white pulse	
	78	Normal to white strobe	
	79	Video to RGB wave	
	80	Video to RGB step	
	81	Video to RGB pulse	
	82	Video to RGB strobe	
	83	Video to video + RGB wave	
	84	Video to video + RGB step	
	85	Video to video + RGB pulse	
	86	Video to video + RGB strobe	
	87-100	<i>No function (reserved for future use)</i>	

Table 13: Pre-programmed FX

Specifications

Physical

Diameter	72 mm (2.9 in.)
Height	34 mm (1.4 in.) not including front
Weight	0.3 kg per meter (0.7 lbs. per ft.)

Control and Programming

Control options	Martin P3™ System Controller (via Martin P3 PowerPort 1500™ or P3 PowerPort 1000 IP™) and/or DMX/RDM
Protocol detection	Automatic
Control modes	RGB, basic
DMX channels	3/10
Setting and addressing	Martin P3™ System controller or RDM-compliant controller
Control resolution	16-bit (P3) or 8-bit (DMX) control of each color
Calibration	Color and intensity for each Dot
DMX compliance	USITT DMX512-A
RDM compliance	ANSI/ESTA E1.20
Firmware update	Via Martin P3™ System controller

Control/User Interface

Device status	Multi-color visual indication
Device test and reset	Magnetic pushbutton to call up dot status and reset dot

Optics

Options

Clear front	
Dome front	
Directional front (TIR lens)	
Minimum LED lifetime	50 000 hours (to >70% luminous output)*
Color resolution	16 bits per color (48 bits per pixel)

*Figure obtained under manufacturer's test conditions

Viewing angle

Clear front	103° x 103° (FWHM)
Dome front	125° x 125° (FWHM)
Directional front	TBA

Photometric Data

Total output

Clear front	100 lumens
Dome front	70 lumens
Directional front	TBA

For full photometric data, see the Martin website at www.martin.com

Video Processing

Brightness control
Gamma correction and control
Color temperature control
Color space control
Calibration processing
Synchronization

Signal Protocol

Martin P3™ system (via Martin P3™ PowerPort) or DMX/RDM

Construction

Base	Cast aluminum
Color	Clear anodized (custom colors available by special order)
Protection rating	IP66
Impact resistance	IK05
Corrosion resistance	C5-M (very high corrosivity / marine, ISO 12944)
RoHS compliant	

Installation

Orientation	Any
Mounting options	Direct surface mount, optional mounting plate or optional mounting profile

Connections

Power and data input	6-pin custom BBD-type IP66-rated
Power and data thru	6-pin custom BBD type IP66-rated
Hot-plugging compatible	

Electrical

Nominal input voltage	48 VDC +/- 4%
Power supply options	Martin P3™ PowerPort 1500, Martin P3™ PowerPort 1000 IP, Martin™ IP66 Power Supply Unit or generic 48 VDC PSU

Power Consumption

Typical total power consumption, calibrated mode	5 W at full intensity, full white
Typical total power consumption, uncalibrated mode	7 W at full intensity, full white
<i>Allow for +/-10% variation in power consumption figures</i>	

Thermal

Cooling	Convection
Maximum ambient temperature (Ta max.) for typical video content	55° C (131° F)
Minimum ambient temperature (Ta min.)	-20° C (-4° F)
Max. total heat dissipation, calculated, +/- 10%	20 BTU/hr.

Approvals



EU safety	EN 60950-1, EN 60950-22
EU EMC	EN 55022, EN 55024
US safety (pending)	UL 60950-1, UL 60950-22
US EMC	CFR Title 47 Part 15 Class A
Canadian safety (pending)	CSA C22.2 No. 60950-1, No. 60950-22
Canadian EMC	ICES-003 Class A
Australia/NZ (pending)	RCM

Accessories

Magnetic Test Tool, set of 10	P/N 91610139
-------------------------------	--------------

Mounting hardware

Surface Mounting Plate, aluminum, Exterior Dot-HP	P/N 91606020
Mounting Profile, Exterior Dot-HP (including dot bracket, screws and lock)	P/N 91606021
Mounting Profile Locks, set of 10	P/N 91611725

Cables

Power + Data Input Cable, 4-pin male XLR (for P3 PowerPort 1500) to fem. BBD, 0.25 m	P/N 11840257
Power + Data Input Cable, 5-pin male XLR + wire tails (for PSU) to female BBD, 0.25 m	P/N 11840276
Power + Data Input Cable, 5-pin male XLR + male Martin™ IP66 PSU to fem. BBD, 0.25 m	P/N 11840275
Power + Data Extension Cable, Installation type CMX, BBD-BBD 1 m	P/N 11840270
Power + Data Extension Cable, Installation type CMX, BBD-BBD, 2.5 m	P/N 11840271
Power + Data Extension Cable, Installation type CMX, BBD-BBD, 5 m	P/N 11840272
Power + Data Extension Cable, Installation type CMX, BBD-BBD, 10 m	P/N 11840273
Power + Data Extension Cable, Installation type CMX, BBD-BBD, 25 m	P/N 11840274
Power + Data Extension Cable, Installation type CMX, without connectors, 100 m	P/N 11840278
DMX Leadout Adapter, male BBD to 5-pin female XLR, 0.25m	P/N 11840258

Connectors

Power + Data Cable Connector, BBD, Male	P/N 91611750
Power + Data Cable Connector, BBD, Female	P/N 91611751
Blanking caps for sealing unused female BBD connectors, set of 10	P/N 62409876

Related Items

Martin P3™ PowerPort 1500	P/N 90721040
Martin P3™ PowerPort 1000 IP, Installation model	P/N 90721080
Martin™ IP66 PSU 240 W external power supply unit	P/N 90760330
Martin P3-050™ System Controller	P/N 90721090
Martin P3-150™ System Controller	P/N 90721015
Martin P3-300™ System Controller	P/N 90721060
Martin P3-PC™ System Controller	P/N 90721030

Ordering Information

Exterior Dot-HP™ RGB

Exterior Dot-HP™ RGB, Aluminum, Clear Front	P/N 90357683
Exterior Dot-HP™ RGB, Aluminum, Diffuser Dome Front	P/N 90357685
Exterior Dot-HP™ RGB, Aluminum, Directional Front (TIR Lens)	P/N 90357686

Exterior Dot-HP™ Cool White

Exterior Dot-HP™ Cool White, Aluminum, Clear Front	P/N 90357688
Exterior Dot-HP™ Cool White, Aluminum, Diffuser Dome Front	P/N 90357687
Exterior Dot-HP™ Cool White, Aluminum, Directional Front (TIR Lens)	P/N 90357689

Specifications subject to change without notice. For the latest product specifications, see www.martin.com

FCC Compliance

This device complies with Part 15 of the FCC Rules. Operation is subject to the following two conditions: (1) This device may not cause harmful interference, and (2) this device must accept any interference received, including interference that may cause undesired operation.

Canadian Interference-Causing Equipment Regulations - *Règlement sur le Matériel Brouilleur du Canada*

This Class A digital apparatus meets all requirements of the Canadian Interference-Causing Equipment Regulations.
Cet appareil numérique de la classe A respecte toutes les exigences du Règlement sur le Matériel Brouilleur du Canada.

EU EMC

Warning! Class A ITE product. Operation of this equipment in a residential environment could cause radio interference.

Not for use in a computer room as defined in the Standard for the Protection of Information Technology Equipment, ANSI/NFPA 75.
Ne peut être utilisé dans une salle d'ordinateurs telle que définie dans la norme ANSI/NFPA 75 Standard for the Protection of Information Technology Equipment.



Disposing of this product

Martin™ products are supplied in compliance with Directive 2002/96/EC of the European Parliament and of the Council of the European Union on WEEE (Waste Electrical and Electronic Equipment), as amended by Directive 2003/108/EC, where applicable.

Help preserve the environment! Ensure that this product is recycled at the end of its life. Your supplier can give details of local arrangements for the disposal of Martin products.



www.martin.com • Olof Palmes Allé 18 • 8200 Aarhus N • Denmark
Tel: +45 8740 0000 • Fax +45 8740 0010