

VC-Grid™ Family

User Manual



© 2012-2015 Martin Professional ApS. Information subject to change without notice. Martin Professional and all affiliated companies disclaim liability for any injury, damage, direct or indirect loss, consequential or economic loss or any other loss occasioned by the use of, inability to use or reliance on the information contained in this document. The Martin logo, the Martin name and all other trademarks in this document pertaining to services or products by Martin Professional or its affiliates and subsidiaries are trademarks owned or licensed by Martin Professional or its affiliates or subsidiaries.

P/N 35000263, Rev. E

Contents

Safety Information.....	4
Introduction	7
Unpacking	7
Precautions to avoid damage	7
VC-Grid overview	9
Physical installation	10
Mounting frames	11
System installation	12
Installing a P3 system	12
Installing a DMX-controlled system	14
Connecting additional devices to a VC-Grid chain	19
System setup	20
Setting up for P3 display	20
Setting up for DMX control	20
Using the VC-Grid.....	23
P3 display	23
DMX control.....	23
Local control button	23
Service and maintenance.....	26
Cleaning.....	26
Installing new software	26
Troubleshooting	27
Specifications	28

Safety Information



WARNING!

Read the safety precautions in this section before installing, powering, operating or servicing this product.

The following symbols are used to identify important safety information on the product and in this document:



Warning!
Safety hazard.
Risk of severe injury or death.



Warning!
Hazardous voltage. Risk of severe or lethal electric shock.



Warning!
Fire hazard.



Warning!
Refer to manual before installing, operating or servicing.



Warning!

- **Read this user manual before installing and operating the Martin VC-Grid™ and keep this manual for future reference.**
- **Follow the safety precautions given in this user manual and in the manuals of all the devices you connect to it. Observe all warnings given in manuals and printed on devices. Make sure that everyone who is involved in working on or using the VC-Grid has read and understood these safety precautions and warnings.**
- **Install, connect, operate and service devices only as described in this manual and connected devices' manuals and only in accordance with local laws and regulations. All Martin™ manuals are supplied with devices and are also available for download from www.martin.com.**
- **The VC-Grid is not for household use. It presents risks of severe injury or death due to fire and burn hazards, electric shock and falls. It must be installed by qualified technicians only.**
- **The VC-Grid does not have user-serviceable parts. Refer any operation not described in this manual to Martin™ or its authorized service agents.**
- **The VC-Grid is designed to integrate with other Martin™ devices in a video display installation.**



VC-Grid modules are considered as components that will be installed into final equipment. It must be reconfirmed that the final equipment still meets applicable EMC (electromagnetic compatibility) standards.

If you have any questions about how to operate the VC-Grid safely, please contact your Martin™ supplier or call the Martin™ 24-hour service hotline on +45 8740 0000, or in the USA on 1-888-tech-180.



PROTECTION FROM ELECTRIC SHOCK

- Read and respect the directions given in the user manuals of all the devices that you intend to connect to the VC-Grid, particularly the instructions, warnings and limits that apply to:
 - system layout,
 - connections to other devices,
 - specified cables,
 - maximum cable lengths, and
 - maximum number of devices that can be connected.
- Use only the cables specified by Martin™ for the devices concerned to interconnect them. If the specified cables are not long enough for an intended cable run, consult Martin™ for assistance in finding or creating a safe alternative cable

- Do not allow the total length of the cables used in a linked chain of VC-Grid modules to exceed 50 m (164 ft.) from the 48 VDC power source (Martin P3 PowerPort 1500™, Martin Tripix Power IP66™ or other external PSU) to the last VC-Grid at the end of the chain.
- Do not exceed the maximum safe limits given in the tables below. The figures allow for cable in a chain with a total hybrid cable length of 50 m (164 ft.).
 - If you supply VC-Grid modules with DC power from an output on a **Martin P3 PowerPort 1500™**, do not connect more than one linked chain of VC-Grids to one DC power output, and respect the limits given in Table 1 below:

Type of VC-Grid module in chain	Maximum permitted number of modules in one chain
VC-Grid 16x16 15	4
VC-Grid 8x8 25	12
VC-Grid 8x8 30	12
VC-Grid 8x8 60	12
VC-Grid 4x4 60	45

Table 1: Maximum number of VC-Grid modules per P3 PowerPort 1500™ output

- If you supply VC-Grid modules with DC power from a **Martin Tripix Power IP66™**, do not connect more than one linked chain of VC-Grids to the DC power output, and respect the limits given in Table 2 below.

Type of VC-Grid module in chain	Maximum permitted number of modules in one chain
VC-Grid 16x16 15	4
VC-Grid 8x8 25	8
VC-Grid 8x8 30	8
VC-Grid 8x8 60	8
VC-Grid 4x4 60	30

Table 2: Maximum number of VC-Grid modules per Tripix Power IP66™

- If you supply a chain of VC-Grid modules with DC power from a **generic 48 VDC external PSU** (power supply unit), do not connect more than one linked chain of VC-Grids to one DC power output at the PSU, and do not exceed the maximum permitted number of modules that you can connect in one chain as given in Table 3 below. At the same time, do not create a chain that will exceed the maximum power rating of the PSU output used to supply that chain with power (to find the power consumption of the chain, multiply the number of modules in the chain with the wattage of each module as given in Table 3).

Each time you reach (a) the maximum permitted number of modules in one chain, or (b) the PSU output's maximum power rating – *whichever you reach first* – you must create a new chain of modules that is connected to a new 48 VDC power output.

Type of VC-Grid module in chain	Maximum permitted number of modules in one chain	Wattage per VC-Grid module
VC-Grid 16x16 15	4	60 W
VC-Grid 8x8 25	12	30 W
VC-Grid 8x8 30	12	30 W

Table 3: Maximum number of VC-Grid modules per 48 VDC external PSU

Type of VC-Grid module in chain	Maximum permitted number of modules in one chain	Wattage per VC-Grid module
VC-Grid 8x8 60	12	30 W
VC-Grid 4x4 60	45	8 W

Table 3: Maximum number of VC-Grid modules per 48 VDC external PSU

- If you supply a chain of VC-Grids with DC power from a **generic 48 VDC external PSU** and the DC output used does not have constant overcurrent protection that limits current to 8 A, install an inline fuseholder with a 7.5 A or 8 A fuse on the circuit that you connect to that DC output.
- Provide a means of locking out AC mains power that allows power to the installation to be shut down and made impossible to reapply, even accidentally, during work on the installation.
- Shut down power to the installation during service and when it is not in use.
- Before applying power to the installation, check that all power distribution equipment and cables are in perfect condition and rated for the current requirements of all connected devices.
- Isolate the installation from power immediately if any product, power cable or power plug is in any way damaged, defective or wet, or if it shows signs of overheating.
- Do not expose the VC-Grid to rain or moisture.



PROTECTION FROM BURNS AND FIRE

- The VC-Grid is cooled by convection. Provide free airflow and a minimum clearance of 10 mm (0.4 in.) around modules. Monitor the VC-Grid's temperature by calling up temperature readouts on the P3 System Controller. If any of the product temperature readouts exceed the levels given in Table 4 on page 8, provide fan assistance to give active cooling to the installation.
- Do not operate the VC-Grid if the ambient temperature (T_a) exceeds 45° C (113° F).
- Do not modify the VC-Grid in any way not described in this manual or install other than genuine Martin™ parts. Use only accessories approved by Martin™.



PROTECTION FROM INJURY

- When installing the VC-Grid above ground level, ensure that the installation hardware and supporting structure can hold at least 10 times the weight of all the devices they support.
- In an overhead installation or where the VC-Grid may cause injury if it falls:
 - block access below the work area and work from a stable platform whenever installing, servicing or moving the VC-Grid, and
 - as soon as work is completed, check that all hardware and components are securely in place and fastened to supporting structures.

Introduction

Thank you for selecting a product from the Martin VC-Grid™ family. These compact LED-based display modules are designed to integrate into a Martin P3™ video system to display video from a variety of sources, and they can also be controlled using DMX. Use of an RDM-compliant DMX controller such as the Martin M1™ or M-PC™ allows two-way communication and remote management of VC-Grid modules from the controller.

The VC-Grid combines flexibility and simplicity with high-quality video display capabilities. Used with or without a front diffuser, multiple VC-Grids can be combined in ways that give exceptional creative flexibility. A hybrid power and data cabling system allows VC-Grids to be daisy-chained for easy setup and minimal cabling.

The VC-Grid is a square array of LEDs arranged on a rigid module. It offers the following features:

- Various pixel pitch (center-to-center LED distance) options: 15, 25, 30 or 60 mm
- Three pixel layout options: 4x4, 8x8 or 16x16 LEDs per module
- Individually controllable pixels
- High-quality 16-bit per color image processing technology
- Pixel-level brightness and color calibration for optimal image quality
- P3 and DMX control with automatic protocol detection
- Intuitive pixel mapping and addressing using a Martin P3™ system controller
- Single hybrid cable for power and data input and throughput
- External power and data processor (Martin P3 PowerPort 1500™) and simple cabling system.

All models are available with RGB color. VC-Grid 8x8 25 models are also available in warm white (WW), medium white (MW) and cool white (CW) versions.

For dimensions drawings of all the products in the VC-Grid family, please see the VC-Grid Product Support pages on the Martin™ website at www.martin.com

The naming convention for the VC family is as follows:

Product name	Pixel layout	Pixel pitch
VC-Grid	16x16	15
VC-Grid	8x8	25

Martin™ user documentation is supplied with products . Please check that you have the latest version available by checking the product's support page on the Martin™ website at <http://www.martin.com>. Besides the latest user documentation, the support pages also provide the latest specifications, firmware updates and support information for Martin™ products.

Martin™ welcomes input from users. Comments or suggestions regarding this manual can be e-mailed to service@martin.dk or posted to: Technical Documentation, Martin Professional A/S, Olof Palmes Allé 18, DK-8200 Aarhus N, Denmark.

Unpacking

The VC-Grid is supplied in anti-static packaging, Leave products in their packaging until you are ready to install them.

Precautions to avoid damage

Important! To get the best out of the VC-Grid and avoid causing damage that is not covered by the product warranty, read the following information carefully. Make sure that everyone who is involved in working on or using the VC-Grid has read and understood this information.

- The VC-Grid™ is not designed to allow hot-plugging. Shut down power and data before connecting or disconnecting modules, or you are very likely to cause damage that is not covered by the product warranty.
- PCB tracks can be damaged if metal screws are tightened directly onto VC-Grid modules. Protect PCBs from damage by adding non-conductive protective material such as plastic PCB washers or spacers

- under screw heads to prevent any abrasion of PCBs. Mechanical damage to PCB tracks caused by fastening hardware is not covered by the product warranty.
- Excessive dirt buildup causes overheating and a risk of short-circuits and may damage the product. Damage caused by inadequate cleaning is not covered by the product warranty.

Operating temperature precautions

- Exposing the VC-Grid to direct sunlight or operating it in an ambient temperature that exceeds the specified maximum may reduce the lifetime of the product. Monitor the VC-Grid’s temperature by calling up temperature readouts on the P3 System Controller. If any of the product temperature readouts exceed the temperatures given in Table 4, provide fan assistance to give active cooling to the installation.

VC-Grid module	Fan assistance required from:
VC-Grid 15	76° C
VC-Grid 25	75° C
VC-Grid 30	69° C
VC-Grid 60 4x4	69° C
VC-Grid 60 8x8	68° C

Table 4: Maximum temperature levels before fan assistance is required

- Note that, if the temperature of a VC-Grid module rises to 10° C above the level given in Table 4, a thermal safety cutout shuts down the module. The module will not function normally again until the temperature has fallen to a safe level.

Electrostatic discharge precautions



VC-Grid components are sensitive to ESD (electrostatic discharge) and can be damaged if you do not take the following precautions:

- Attach an ESD wrist strap to your wrist and connect its ground (earth) lead to a known ground (earth) before handling the VC-Grid.
- Hold the VC-Grid by its edges only. Do not touch any part of a VC-Grid module apart from the connectors and the control button. Do not touch connector pins.
- Place the VC-Grid on grounded (earthed) surfaces only.
- Store the VC-Grid only in its ESD shielding bag and do not remove it until you are ready to install it. Place it in an ESD shielding bag immediately if you remove it from an installation.
- Protect the VC-Grid from ESD in the installation location. Differences in electrical potential between the VC-Grid and any object it comes into contact with may cause damage that is not covered by the product warranty.

VC-Grid overview

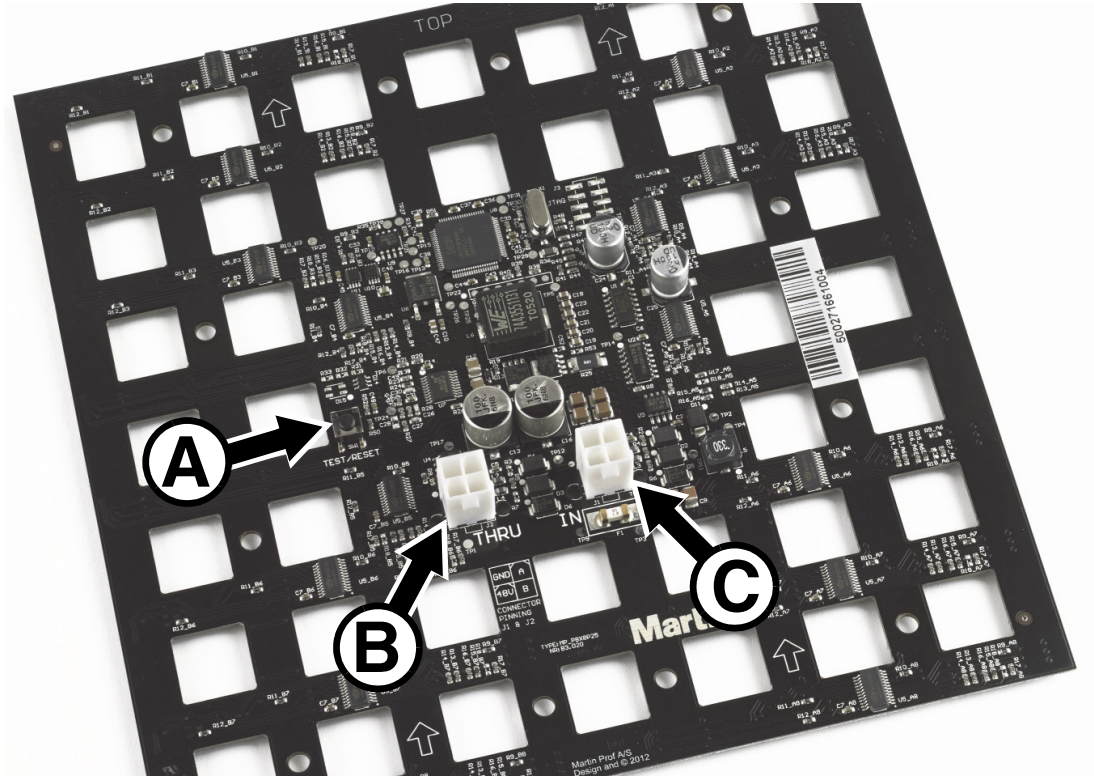

VC-Grid 8x8 25 illustrated

Connectors B and C have right-angled design on other models

- A - Control button**
- B - 48 VDC power + data throughput (THRU)**
- C - 48 VDC power + data input (IN)**

Figure 1: Overview

Physical installation



Warning! Read “*Safety Information*” on page 4 and “*Precautions to avoid damage*” on page 7 before installing the VC-Grid.

The VC-Grid can be installed in any orientation.

The backs of modules are marked with arrows and the word **TOP**. To ensure the most evenly matched optical characteristics when viewing VC-Grids at an angle, install all modules with the arrows facing the same way. In vertical arrays, install all modules with the arrows pointing upwards and the **TOP** marking at the upper edge of the modules.

Allow free airflow around the product and at least 10 mm (0.4 in.) of clearance around the LEDs on the front surface.

To maintain even pixel spacing across multiple VC-Grids so that they form a seamless display surface, install them with the following gaps between the edges of modules, both horizontally and vertically:

- VC-Grid 16x16 15 5 mm
- VC-Grid 8x8 25 15 mm
- VC-Grid 8x8 30 20 mm
- VC-Grid 8x8 60 40 mm
- VC-Grid 4x4 60 40 mm

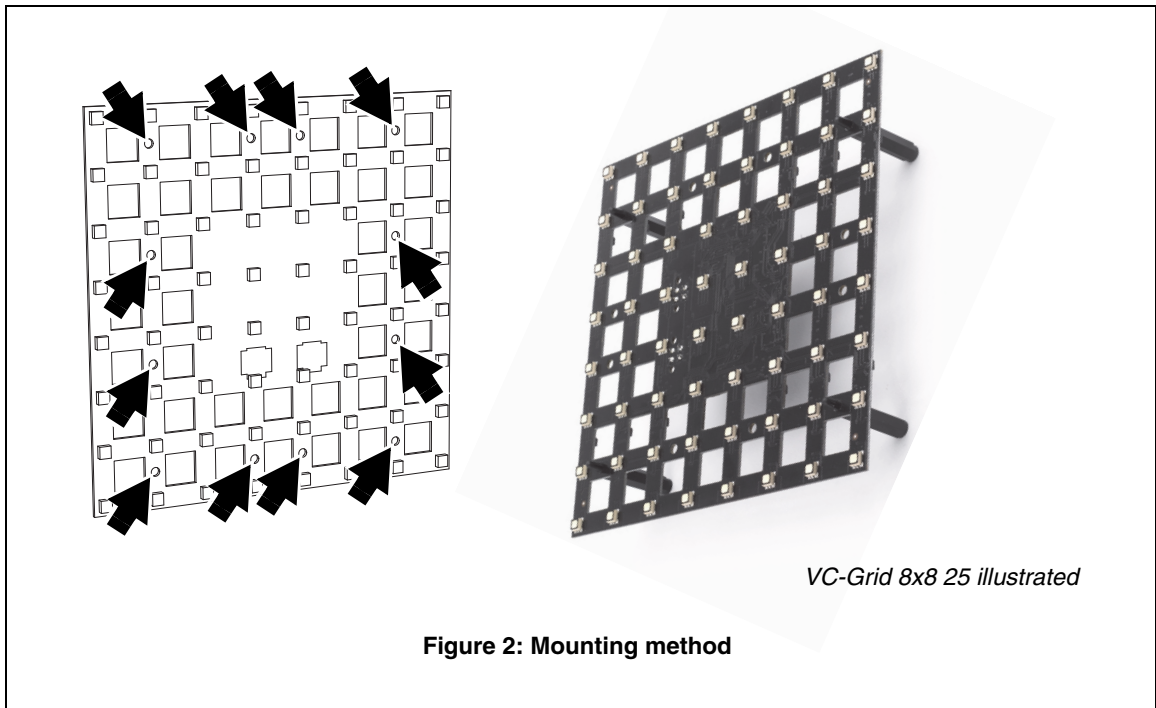

See Figure 2. The VC-Grid can be fastened to a surface or structure using pillar bolts through any four of the mounting holes (arrowed). Arrange pillar bolts so that they are evenly spaced around the product. Add non-conductive washers on both sides of the VC-Grid.

Mounting frames

See Figure 3. Mounting frames for the VC-Grid that simplify the installation process are available from Martin™. See “Mounting accessories” on page 31 for details.

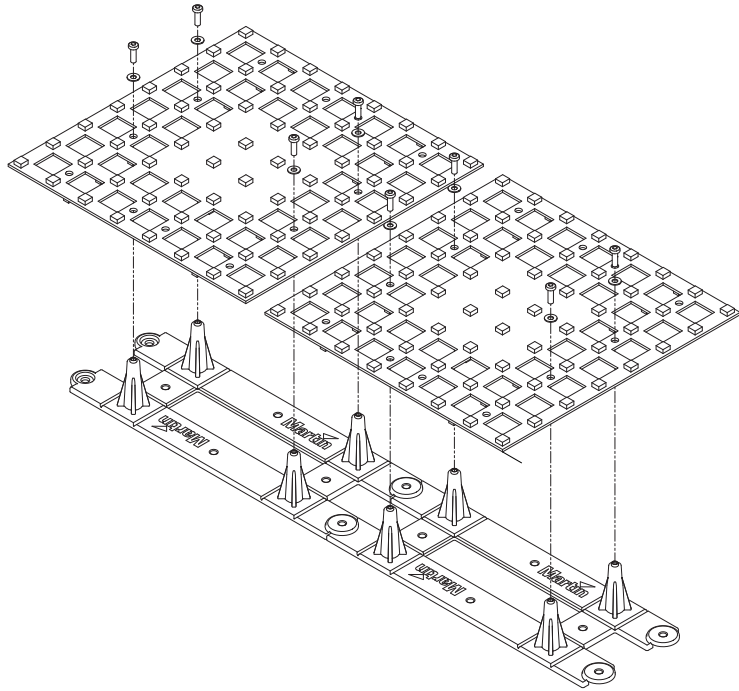

Figure 3. Martin™ Mounting Frames

System installation



Warning! Read “Safety Information” on page 4 and “Precautions to avoid damage” on page 7 before installing a VC-Grid™ system. Pay particular attention to the limits given in “Protection from electric shock” on page 4.



Warning! Connect the VC-Grid™ only to the devices specified in this manual and only using the Martin™ cables specified in this manual.



Warning! Do not exceed the maximum numbers of devices that can be connected in chains and maximum cable lengths specified in “Protection from electric shock” starting on page 4 and in the manuals of the other devices in the system.

Important! The VC-Grid is not designed to allow hot-plugging. Shut down power and data before connecting or disconnecting modules, or you will probably cause damage that is not covered by the product warranty.

The VC-Grid is designed to display either Martin P3™ video or DMX-controlled lighting effects. It automatically recognizes and responds to either a P3 or a DMX data signal. The next sections explain how to create a VC-Grid installation to display P3 video data or DMX-controlled lighting effects.

Installing a P3 system

See Figure 5 for an overview of the elements and layout of a Martin P3™ video display system.

The P3 link requires Ethernet Cat 5e or better network cable. The cable run between any two devices on the link can be up to 100 m (328 ft.) in length. If necessary, a cable run can be extended beyond 100 m by inserting an unmanaged Ethernet switch or using a fiber-optic system (see the P3™ system controller user manual for details).

To install a system that displays Martin P3™ video on VC-Grids, see the overview in Figure 5 and follow these directions:

1. Make sure that no devices in the installation can be connected to AC mains power until all installation work is complete.
2. Read “Safety Information” on page 4 and “Precautions to avoid damage” on page 7.
3. Connect VC-Grid modules together in chains using Martin™ hybrid PCB-to-PCB cables (see “VC-Grid to VC-Grid link cables” on page 31). Connect each cable from the THRU connector on one VC-Grid to the IN connector on the next VC-Grid to create the chain.

Warning! Respect the maximum lengths for chains given in “Protection from electric shock” on page 4.

4. Connect each chain of VC-Grids to one of the four 4-pin female XLR hybrid (48 VDC power + P3 data) outputs on a P3 PowerPort 1500™ using a Martin™ hybrid 4-pin male XLR to PCB adapter cable, P/N 11840158 (see Figure 4).

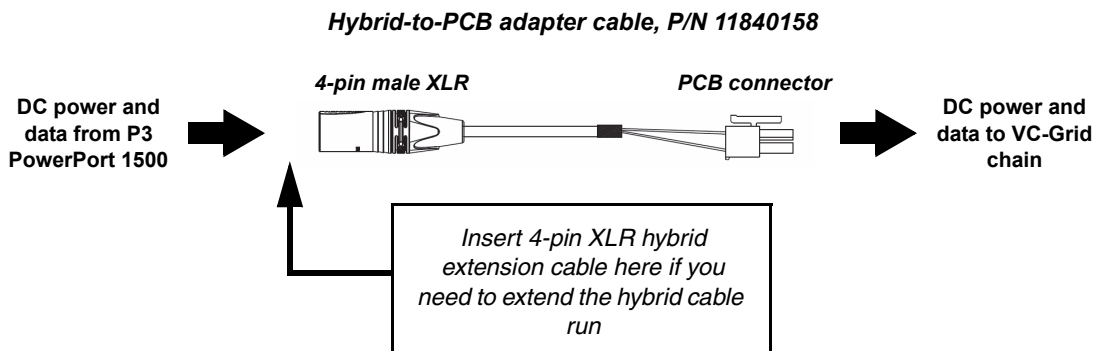
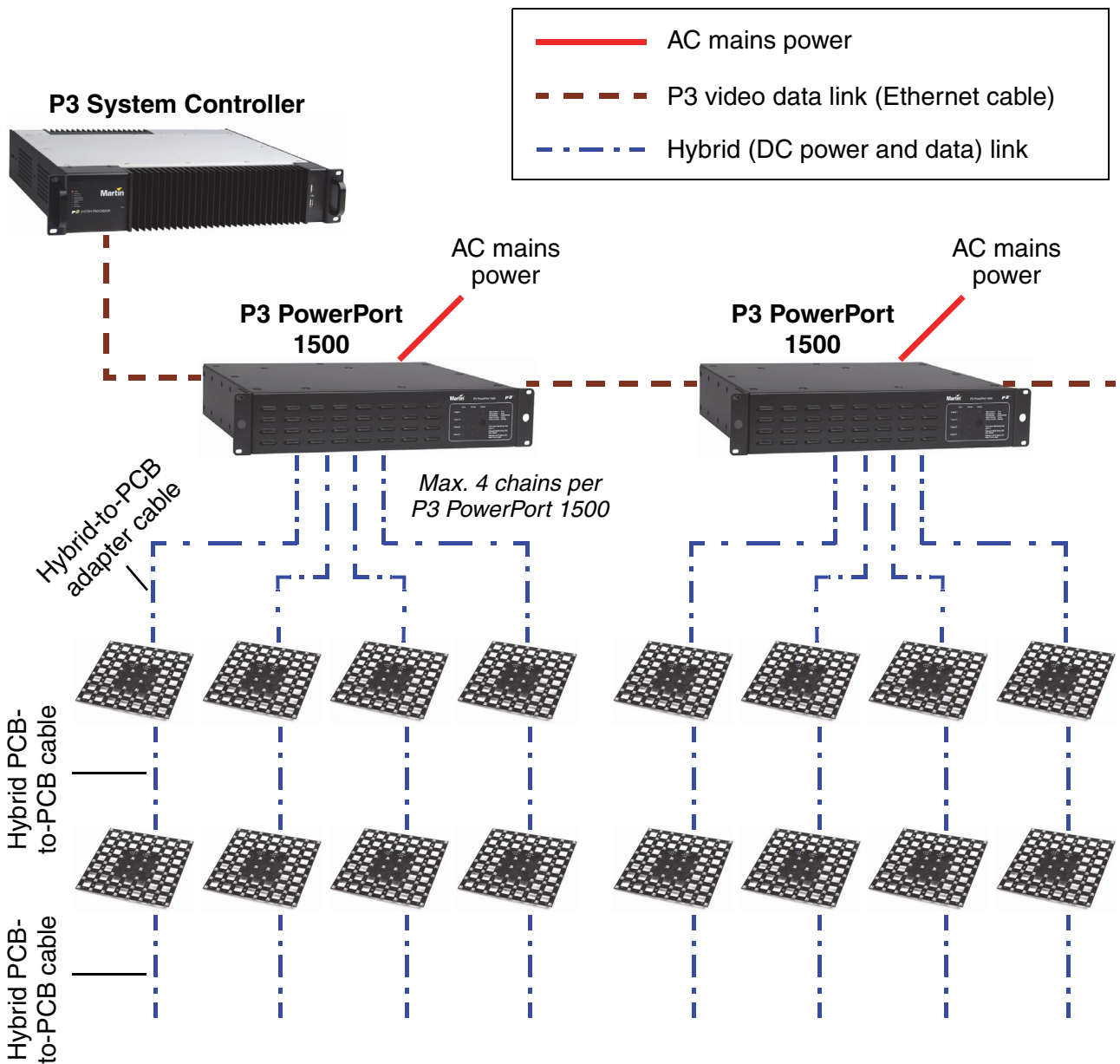

Figure 4: Power and P3 video data input

5. If necessary, extend the cable by connecting a Martin™ 4-pin XLR hybrid extension cable to the Hybrid-to-PCB adapter cable so that you can run the hybrid link to the P3 PowerPort 1500. Suitable extension cables are available from Martin™ in various lengths. See “Extension cables” on page 31.

6. Create a P3 video data link from a Martin P3™ system controller such as the P3-100™, P3-200™ or P3 PC™ to the P3 PowerPort 1500™ (see the products' user manuals for details).
 7. If required, continue the P3 video data link in a daisy-chain by connecting the P3 data throughput of one P3 PowerPort 1500™ to the P3 data input of the next, as described in the P3 PowerPort 1500™ user manual. You can connect up to fifty P3 PowerPort 1500s in a P3 data daisy-chain like this. If you need to connect more than fifty, use an unmanaged Ethernet switch to split the P3 data link into branches, each containing less than fifty P3 PowerPort 1500s.
 8. Connect the P3 PowerPort 1500™ to AC mains power at 100 - 240 V, 50/60 Hz as described in its user manual.
 9. connect the P3 system controller to AC mains power and power the controller on.
- You can now configure the system at the P3 controller. See "System setup" on page 20.



See Table 1 on page 5 for maximum permitted number of modules in chain

Figure 5: P3 system layout

Installing a DMX-controlled system

In a DMX-controlled system, an RDM-compliant DMX lighting controller sends a DMX control data signal over a DMX link to the installation, and then over the hybrid link to the VC-Grids.

The DMX link requires DMX cable. It can be maximum 300 m (1000 ft.) in length and must run in one single daisy-chain, but it can be extended or split into branches using an RDM-compliant amplifier/splitter such as the Martin RDM 5.5 Splitter™ (P/N 90758150). Alternatively, you can run the DMX signal from the controller over Ethernet cable using Art-Net protocol and convert it to a DMX-compliant signal with a Martin Ether2DMX8™ DMX router (P/N 90758130).

If you would like assistance with creating a DMX link, your Martin™ supplier will be glad to advise.

The number of VC-Grids that you can control on one DMX link is limited by the number of DMX channels the VC-Grids will use and the 512 DMX channels available in one DMX universe at the DMX controller. Each time you have used 512 channels, you must create a new DMX link that is connected to a new DMX universe on the controller. Note that this limit applies to the *DMX link*. The maximum safety limits that apply to the *hybrid link* (see “Safety Information” on page 4) take priority and must be respected in all cases.

DC Power options in DMX installations

A DMX-controlled VC-Grid installation can be supplied with DC power from the Martin Tripix Power IP66™ external PSU or from a generic external PSU that can supply DC power at 48 V (the Mean Well SP-480 48, for example).

The hardware and cables required are slightly different depending on which type of PSU you use to supply the installation with DC power. The two different types of installation are covered in the next two sections:

- If you are using a Martin Tripix Power IP66™ PSU, see “Installing a DMX system using the Tripix Power IP66™” on page 15.
- If you are using a generic 48 VDC PSU, see “Installing a DMX system using a generic 48 VDC external PSU” on page 17.

Installing a DMX system using the Tripix Power IP66™

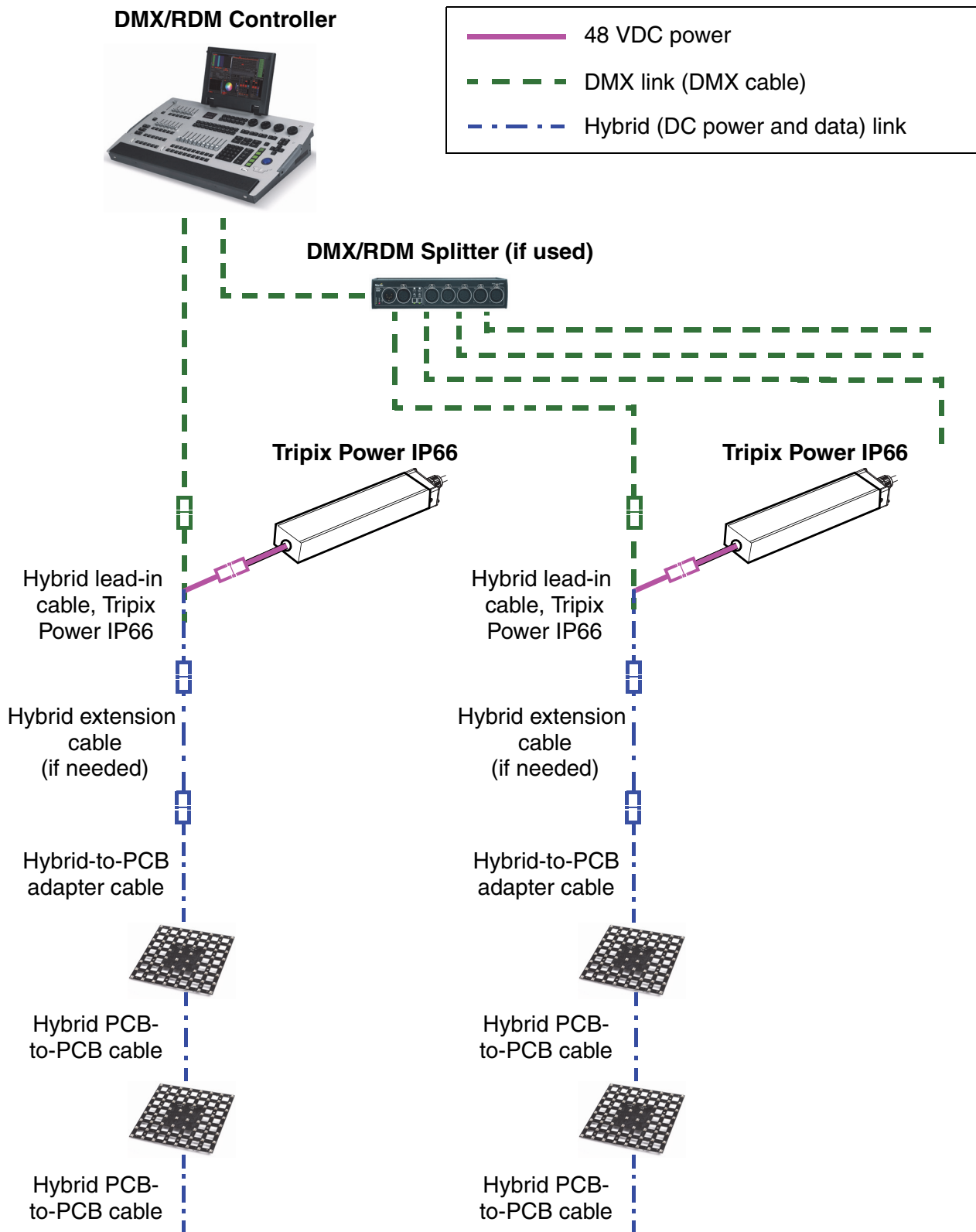

See Table 2 on page 5 for maximum permitted number of modules in chain

Figure 6: DMX system layout using the Tripix Power IP66 PSU

To create a DMX-controlled installation that draws DC power from the Martin Tripix Power IP66:

1. See Figure 6 on page 15 for an overview of this type of installation
2. Make sure that no devices in the installation can be connected to AC mains power until all installation work is complete.
3. Read “Safety Information” on page 4 and “Precautions to avoid damage” on page 7.
4. Connect VC-Grids together in daisy-chains using Martin™ hybrid PCB-to-PCB cables (see “VC-Grid to VC-Grid link cables” on page 31). Connect each cable from the THRU connector on one VC-Grid to the IN connector on the next VC-Grid.

Warning! Do not exceed the maximum permitted number of modules per chain given in Table 2 on page 5.

5. See Figure 7. Connect a Martin™ hybrid-to-PCB adapter cable (P/N 11840158) to the first VC-Grid of each chain.
6. If necessary, you can extend the hybrid link by connecting a Martin™ 4-pin XLR hybrid extension cable to the Hybrid-to-PCB adapter cable. Suitable extension cables are available from Martin™ in various lengths. See “Extension cables” on page 31.
7. See Figure 7. Connect the DC power input connector of a Martin™ Tripix Power IP66 hybrid lead-in cable (P/N 11840194) to the DC output on the Tripix Power IP66.

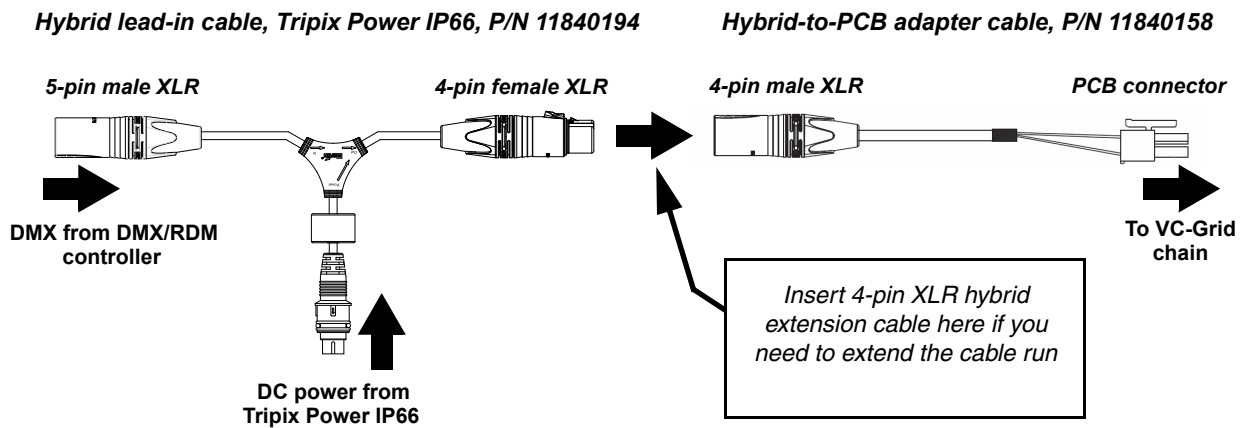
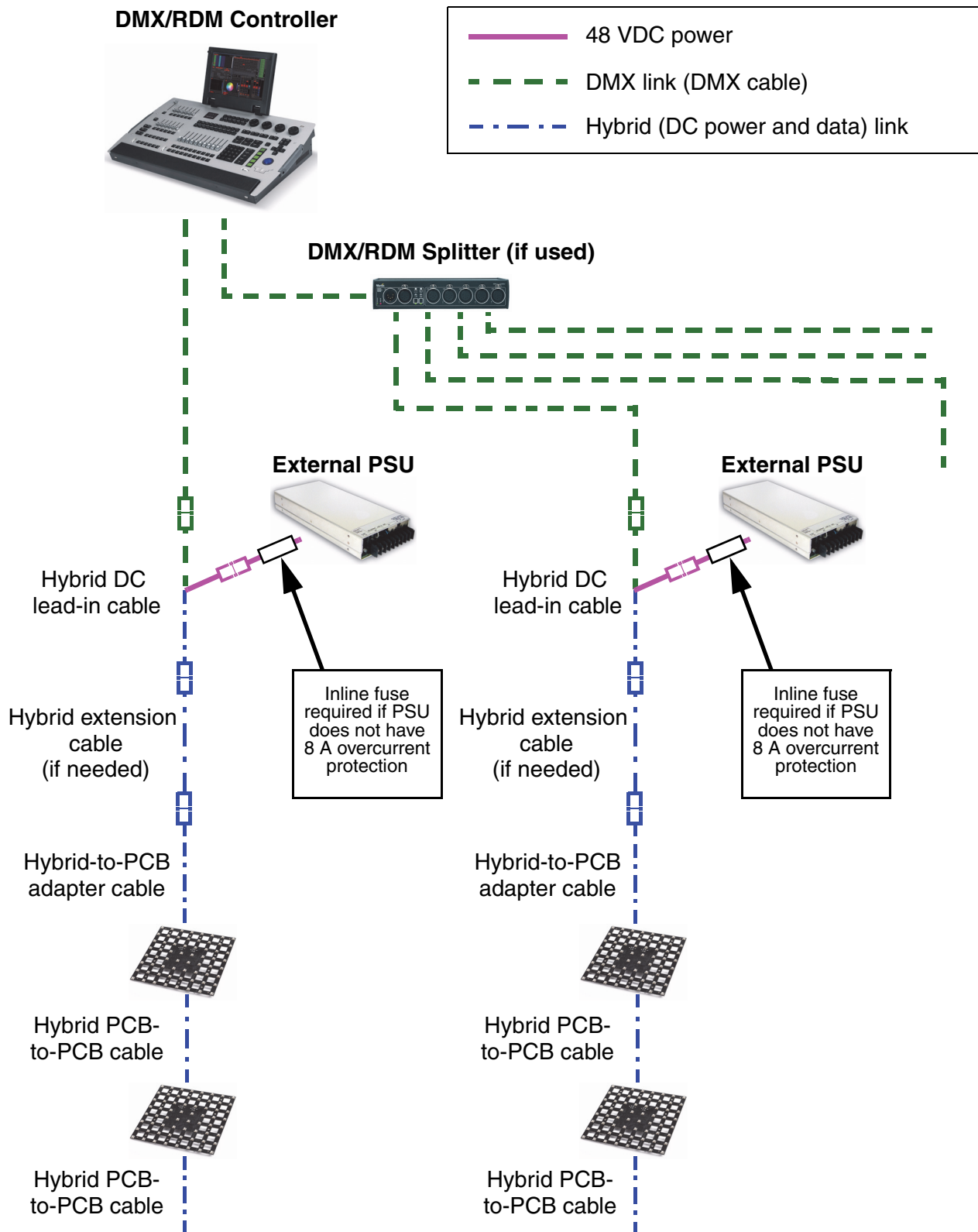

Figure 7: Tripix Power IP66 and DMX connections to a VC-Grid chain

8. Connect the 4-pin female XLR connector on the hybrid lead-in cable to the 4-pin male connector on the hybrid-to-PCB adapter cable (or on the hybrid extension cable, if you have extended the hybrid link).
9. Connect the 5-pin male XLR connector on the hybrid lead-in cable to a DMX link that carries a DMX signal from an RDM-compliant DMX controller such as the Martin M1™ or M-PC™.
10. Install a mains power cable on the Tripix Power IP66 and connect it to AC mains power.
11. Apply AC mains power to the DMX controller.

You can now configure the system. See “System setup” on page 20.

Installing a DMX system using a generic 48 VDC external PSU



See Table 3 on page 5 for maximum permitted number of modules in chain. Do not exceed PSU output rating.

Figure 8: DMX system layout using generic external PSU

To create a DMX-controlled installation that draws DC power from a generic 48 VDC PSU:

1. See Figure 8 on page 17 for an overview of this type of installation.
2. Make sure that no devices in the installation can be connected to AC mains power until all installation work is complete.
3. Read “Safety Information” on page 4 and “Precautions to avoid damage” on page 7.
4. Connect VC-Grids together in chains using Martin™ hybrid PCB-to-PCB cables (see “VC-Grid to VC-Grid link cables” on page 31). Connect each cable from the THRU connector on one VC-Grid to the IN connector on the next VC-Grid.

Warning! Check the PSU’s DC output power rating in watts and the power consumption figures in watts for VC-Grid modules given in Table 3 on page 5. Do not create a chain of VC-Grid modules that will exceed the power rating of the DC output on the PSU. Even if the PSU’s DC output power rating would be high enough, do not create a chain of VC-Grids that contains more than the maximum permitted number per chain given in Table 3 on page 5.

5. See Figure 9. Connect a Martin™ hybrid-to-PCB adapter cable (P/N 11840158) to the first VC-Grid of each chain.
6. If necessary, you can extend the hybrid link cable run by connecting a Martin™ 4-pin XLR hybrid extension cable to the Hybrid-to-PCB adapter cable. Suitable extension cables are available from Martin™ in various lengths. See “Extension cables” on page 31.
7. See Figure 9. If the PSU does not have constant overcurrent protection that will limit current to 8 A on the DC output used, install an inline fuseholder with a 7.5 A or 8 A fuse on the white (+ve) power wire of a Martin™ hybrid lead-in cable (P/N 11840171). A 30 amp automotive-type inline fuseholder with a 7.5 A blade fuse can be used. Connect the power wires on the lead-in cable to a DC output on the PSU. Connect the white wire to positive (+ve) and the black wire to negative (-ve).

Hybrid DC lead-in cable, P/N 11840171

Hybrid-to-PCB adapter cable, P/N 11840158

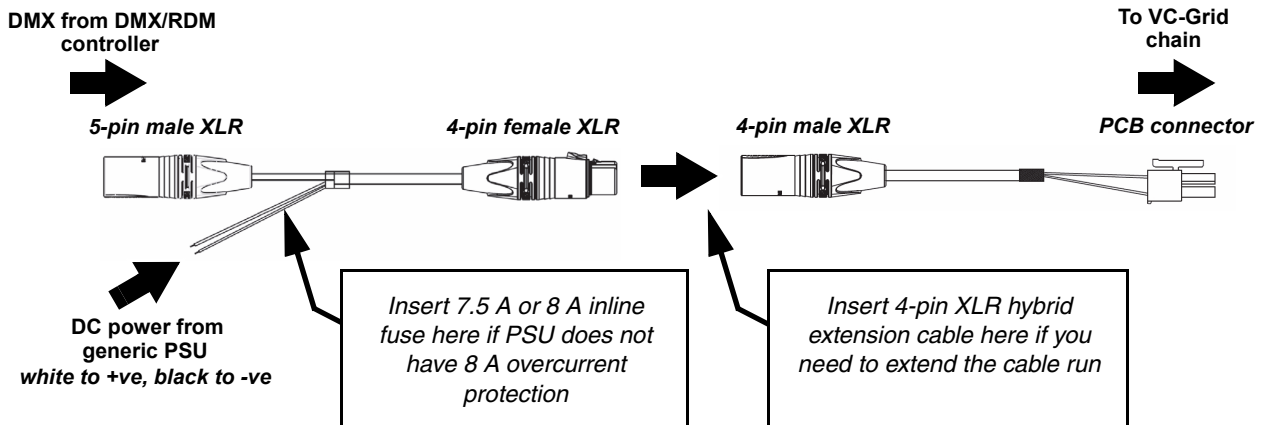

Figure 9: Generic PSU and DMX connections to a VC-Grid chain

8. Connect the 4-pin female XLR connector on the hybrid lead-in cable to the 4-pin male connector on the hybrid-to-PCB adapter cable (or on the hybrid extension cable, if you have extended the hybrid link).
9. Connect the 5-pin male XLR connector on the hybrid lead-in cable to a DMX link that carries a DMX signal from an RDM-compliant DMX controller such as the Martin M1™ or M-PC™.
10. Apply AC mains power to the external PSU.
11. Apply AC mains power to the DMX controller.

You can now configure the system. See “System setup” on page 20.

Connecting additional devices to a VC-Grid chain

Drawing off combined data and DC power from the end of a chain

If you want to continue the hybrid link to carry 48 VDC power and a P3 video or DMX signal from the end of a VC-Grid chain to other devices, connect a Martin Hybrid Adapter Cable, PCB to 4-pin female XLR, P/N 11840159, to the **OUT** connector of the last module in the chain.



Warning! If you draw off DC power from the end of a VC-Grid chain and connect additional devices, respect the maximum safe power rating of the power source that you use to supply all the devices with DC power. Calculate the power consumption of the VC-Grid chain using the figures in Table 3 on page 5, then add the power consumption of each device that you add to the end of the chain. As soon as you reach 360 W – or the maximum power rating of the device that you use to supply the chain with DC power if this rating is lower than 360 W – you must stop adding devices and create a new chain that draws DC power from a new source.

Drawing off a DMX signal from the end of a chain

If you want to continue the DMX link to carry a DMX signal from the end of a VC-Grid chain to other devices, connect a Martin Hybrid Adapter Cable, PCB to 4-pin female XLR, P/N 11840159, to the **OUT** connector of the last module in the chain.

Then, to connect to a standard DMX link that uses 5-pin XLR connectors, add a Martin Data Out/Thru Adapter Cable, 4-pin male XLR to 5-pin female XLR, P/N 11840203. This adapter cable relays the DMX data signal only, it does not collect DC power at its 4-pin male XLR connector.

System setup



Warning! Read “*Safety Information*” on page 4 and “*Precautions to avoid damage*” on page 7 before applying power to the VC-Grid.

Setting up for P3 display

A Martin P3™ system allows video to be displayed on an installation that consists of or includes VC-Grid devices. When a P3 controller is connected to the data link and the installation is powered on, you can set up all the devices on the link from the P3 controller. See the P3 controller user manual for details.

Setting up for DMX control

A DMX system gives 0 - 100% variable intensity control. Varying the intensity of red, blue and green LEDs in RGB products provides RGB color mixing.

You can set up and control a VC-Grid installation over the data link using an RDM-compatible DMX controller such as the Martin M-PC™ Windows application (running on a PC connected to a USB/DMX interface such as the Martin USB Duo™ DMX Interface) or the Martin M1™ DMX/RDM control console. The interface on the Martin M1™ monitor screen is basically identical to the Martin M-PC™ interface.

DMX control channels

DMX controllers send control data on DMX control channels in DMX universes. One DMX universe has 512 channels available. RGB control of each individually controlled element in an installation requires three channels, white intensity control requires one channel.

A VC-Grid installation can be controlled as groups of pixels or as individual pixels. One group can consist of an entire installation, any number of modules or a single module.

- If VC-Grids are set up for grouped control, all the LEDs in each group are controlled using the same DMX channels – three channels for RGB products and one channel for WW, MW and CW products.
- If VC-Grids are set up for individual pixel control, each LED on a module is controlled as an individual pixel using its own DMX channels – three channels per pixel for RGB products and one channel per pixel for WW, MW and CW products.

Type of VC-Grid module	DMX channels per module, individual module control	DMX channels per module, individual pixel control
VC-Grid 16x16 15 RGB	3	192 (LEDs controlled in groups of four)
VC-Grid 8x8 25 RGB	3	192
VC-Grid 8x8 25 CW	1	64
VC-Grid 8x8 25 MW	1	64
VC-Grid 8x8 25 WW	1	64
VC-Grid 8x8 30 RGB	3	192
VC-Grid 8x8 60 RGB	3	192
VC-Grid 4x4 60 RGB	3	48

Table 5: Number of DMX channels required per VC-Grid™ module

A VC-Grid installation uses the number of DMX channels required by the group or pixel (three channels for RGB and one channel for WW, MW or CW) multiplied by the total number of groups or pixels in the installation. For example, an installation with fifty 8x8 RGB modules will require:

- 3 DMX channels if the entire installation is controlled as one group,
- 3 channels x 10 groups = 30 DMX channels if the installation is divided into ten groups that are controlled individually,
- 3 channels x 50 modules = 150 DMX channels if each of the fifty modules is controlled as an individual group, and
- 3 channels x 50 modules x 64 pixels = 9600 DMX channels if each of the 3200 pixels is controlled individually (in this example, 19 DMX universes will be required because one DMX universe has 512 channels).

Individual and grouped control can be mixed freely in an installation. For example, some VC-Grid modules can be set up for individual pixel control, other modules can be set up for individual module control, and other modules can be put into groups for grouped control of multiple modules.

DMX addresses

The system must be set up so that each individually controlled group or pixel receives instructions from the DMX controller on its own DMX channels. The DMX address, also known as the control address or start channel, is the first of these channels. If a unit uses more than one channel, it uses the DMX address channel and the channels immediately above it. For example, one VC-Grid RGB module controlled as one group and set to DMX address 1 will use DMX channels 1 - 3. Channel 4 will be available for use as a DMX address for the next device.

If a VC-Grid module is set to individual pixel control (see “Setting modules to grouped or pixel control modes” on page 22), LEDs are given DMX addresses using a ‘left-to-right, then down’ numbering system (like the reading order you are using for the words on this page). For example, if one VC-Grid 8x8 RGB module is set to pixel control and set to DMX address 1, each of the 64 LEDs will use 3 channels, and the module will use DMX channels 1 - 192 (Channel 1 -3 for the top-left pixel, channels 4 - 6 for the next pixel on the right etc. until it reaches channels 190 - 192 for the last pixel at the bottom on the right. Channel 193 will be available for use as a DMX address for the next device.

If a VC-Grid module is set to module control (see “Setting modules to grouped or pixel control modes” on page 22), it can be controlled as an individual module or assigned to a group of modules. To create a group of modules, give them the same DMX address. All modules that have the same DMX address will receive the same instructions and behave identically.

Setting up via RDM using Martin M-PC™

Using an RDM-compliant DMX controller such as Martin M-PC™, you can communicate with the VC-Grid modules on the DMX data link via RDM. You can:

- Retrieve data
- Set the DMX addresses of the groups or pixels on the link
- Apply various setup options.

To use Martin M-PC, connect a PC running this application to the data link using the Martin USB Duo™ USB/DMX interface box.

See Figure 10. Open the **RDM View** window in M-PC and click on the **Scan** button (arrowed bottom left) to display a list of the RDM-compliant devices on the DMX/RDM data link (in this example, ten VC-Grid RGB modules are present on the link, and all ten modules are set to DMX address 1).

Identifying VC-Grids in the installation

To see which VC-Grid module in this list corresponds to which VC-Grid module in the installation, click on each VC-Grid module in the list once to select it, then click on the **Identify** button at the bottom of the screen. The VC-Grid in the installation that corresponds to the selected VC-Grid in the list will flash a signal so that you can identify it.

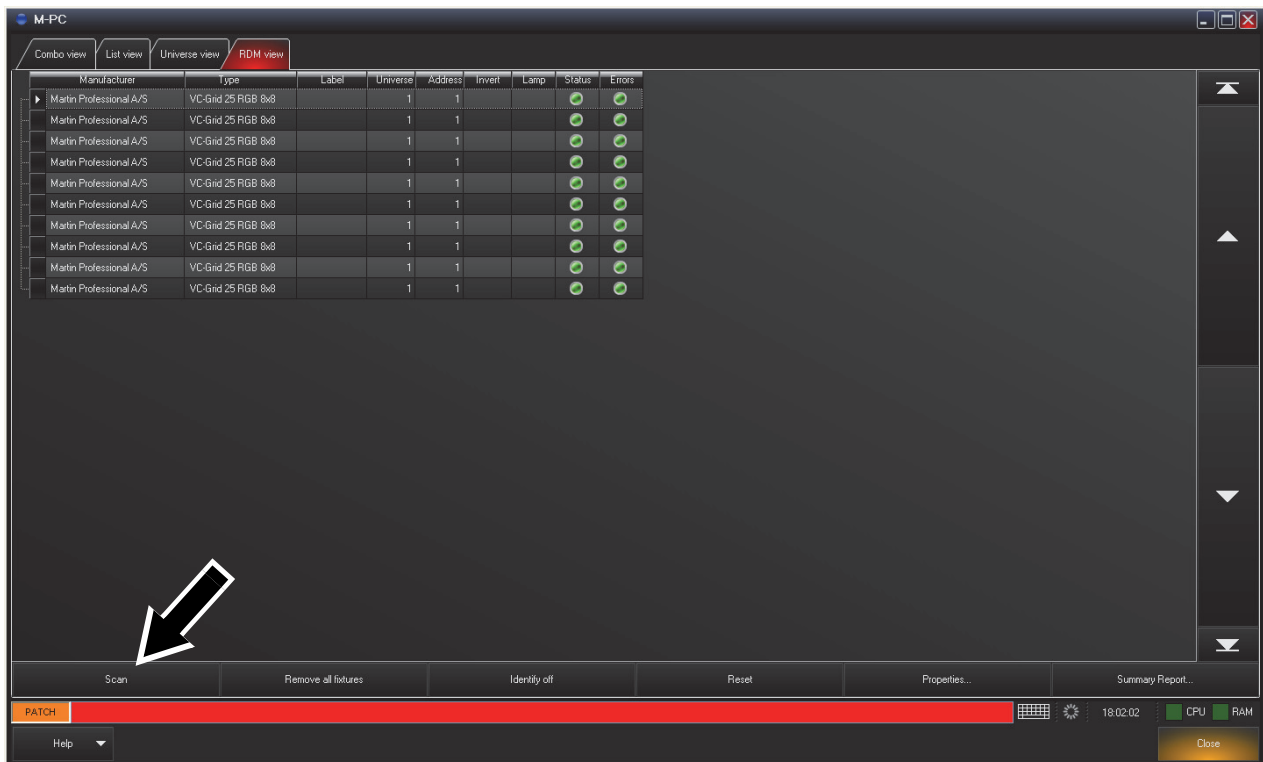

Figure 10: M-PC RDM View

Setting DMX Addresses

See Figure 10. To set DMX addresses using the M-PC application, open the **RDM View** window and click on **Scan** to display a list of the elements in the installation. Click in the **Address** box for each VC-Grid module and enter the desired DMX address, then press the **Enter** key to store the DMX address for that module. Remember that modules with identical addresses will receive the same instructions.

When working with more than one DMX universe, click in the **Universe** box for each VC-Grid module, enter the desired DMX universe number, then press the **Enter** key to store the DMX universe for that module.

Setting modules to grouped or pixel control modes

In pixel mode, each pixel on a module is controlled individually (apart from the VC-Grid 16x16, on which pixels are controlled in groups of four).

In module mode, All the pixels on one module are controlled together as one group.

To set a VC-Grid module to pixel or module mode using M-PC, open the **RDM View** window and click on **Scan** to display a list of the elements in the installation. Select the module in the list, then click on the **Properties...** button at the bottom of the screen to open the Properties window for that module. Select from:

- Pixel mode (calibrated)
- Module mode (calibrated)

Using the VC-Grid



Warning! Read “*Safety Information*” on page 4 and “*Precautions to avoid damage*” on page 7 on before applying power to the VC-Grid.

Do not use the VC-Grid if the ambient temperature exceeds 45° C (113° F) or falls below -20° C (-4° F). See page 8. Monitor component temperatures with reference to Table 4 and be prepared to provide fan-assisted cooling if necessary.

P3 display

The VC-Grid will display video from all common video sources sent via a P3 controller. See the P3 controller documentation for details.

DMX control

The VC-Grid will display effects controlled by DMX and communicate with an RDM-compatible DMX controller.

Local control button

The small control button on the back of the VC-Grid (see Figure 1 on page 9) lets you display the product’s status, test the LEDs and reset the VC-Grid.

Status display

To display a VC-Grid module’s status, press the control button once. Four LEDs in the top-left corner of the module will give one of the indications listed in the tables below for a few seconds:

Color	Output	Indication	Action required
Blue	Constant	Busy (e.g. booting up or writing to flash memory).	Wait a moment for normal operation to be resumed.
Red	Constant	Error. The VC-Grid has encountered a fatal error and can not run.	Perform a factory reboot, followed by a firmware upload.
Red	Flashing	No control source detected.	Connect a P3 system controller or DMX source to the network.
Green	Flashing	Ready. VC-Grid connected to P3 controller but not receiving valid P3 data stream.	Set up the P3 controller to use the VC-Grid.
Green	Constant	Running normally in P3 mode.	None.
Cyan	Flashing	Ready. VC-Grid connected to DMX controller but not receiving valid DMX data stream.	Set up the DMX controller to use the VC-Grid.
Cyan	Constant	Running normally in DMX mode.	None.

Table 6: RGB models status information

VC-Grid CW, MW and WW

LEDs	Output	Indication	Action required
LEDs 1 and 3	Constant	Busy (e.g. booting up or writing to flash memory).	Wait a moment for normal operation to be resumed.
LED 1	Constant	Error. The VC-Grid has encountered a fatal error and can not run.	Perform a factory reboot, followed by a firmware upload.
LED 1	Flashing	No control source detected.	Connect a P3 system controller or DMX source to the network.
LEDs 1 and 2	Flashing	Ready. VC-Grid connected to P3 controller but not receiving valid P3 data stream.	Set up the P3 controller to use the VC-Grid.
LEDs 1 and 2	Constant	Running normally in P3 mode.	None.
LEDs 1, 2 and 3	Flashing	Ready. VC-Grid connected to DMX controller but not receiving valid DMX data stream.	Set up the DMX controller to use the VC-Grid.
LEDs 1, 2 and 3	Constant	Running normally in DMX mode.	None.

Table 7: White models status information

Testing, rebooting and returning to defaults

The tables below list the functions of the control button on each VC-Grid module.

Test patterns are stored in onboard memory. This lets you test the LEDs without an external controller, but test patterns can also be called up on P3 system controllers and the P3 PowerPort 1500™.

Button action	Function
Short press	The first press displays status as shown in Table 6 for a few seconds. The next presses display the following test patterns on the LEDs (one short press scrolls to next pattern): <ul style="list-style-type: none"> - Calibrated white - Full red - Full green - Full blue - Vertical scrolling gradient - Dimmed (20%) uncalibrated white
Press and hold until all LEDs light blue	Reboot the VC-Grid.
Press and hold until all LEDs light white	Return the VC-Grid to its default factory firmware.

Table 8: RGB control button functions

VC-Grid CW, MW and WW

Button action	Function
Short press	The first press displays status as shown in Table 7 for a few seconds. The next presses display the following test patterns on the LEDs (one short press scrolls to next pattern): <ul style="list-style-type: none">- Calibrated white 100%- White 33%- White 33%- White 33%- Scrolling gradient- Dimmed (20%) uncalibrated white
Press and hold until LEDs 1, and 3 light	Reboot the VC-Grid.
Press and hold until LEDs 1, 2, 3 and 4 light	Return the VC-Grid to its default factory firmware.

Table 9: White models control button functions

Service and maintenance



Warning! Read “Safety Information” on page 4 and “Precautions to avoid damage” on page 7 before carrying out service on the VC-Grid.

Warning! Isolate the installation from AC mains power before servicing.



Warning! Refer any service operation not described in this manual to a qualified service technician.

Important! Excessive dirt buildup causes overheating and a risk of short-circuits and may damage the product. Damage caused by inadequate cleaning is not covered by the product warranty.

Important! The VC-Grid is not designed to allow hot-plugging. Shut down power and data before connecting or disconnecting modules, or you will probably cause damage that is not covered by the product warranty.

The user will need to clean the VC-Grid periodically. All other service operations on the VC-Grid must be carried out by Martin Professional™ or its approved service agents.

Installation, on-site service and maintenance can be provided worldwide by the Martin Professional Global Service organization and its approved agents, giving owners access to Martin's expertise and product knowledge in a partnership that will ensure the highest level of performance throughout the product's lifetime. Please contact your Martin supplier for details.

Cleaning

Cleaning schedules vary greatly depending on the operating environment. It is therefore impossible to specify precise cleaning intervals for the VC-Grid. In extreme cases, the product may require cleaning after surprisingly few hours of operation. Environmental factors that may result in a need for frequent cleaning include:

- Use of smoke or fog machines.
- High airflow rates (near air conditioning vents, for example).
- Presence of cigarette smoke.
- Airborne dust (from stage effects, building structures and fittings or the natural environment in outdoor locations, for example).

If one or more of these factors is present, inspect products soon after installing them to see whether cleaning is necessary. Check again at frequent intervals. This procedure will allow you to assess cleaning requirements in your particular situation. If in doubt, consult your Martin™ dealer about a suitable maintenance schedule.

Important! *Electrostatic discharges may cause damage. Do not touch the VC-Grid with fingers or a compressed air nozzle.*

To clean the product, use low-pressure compressed air to gently remove dust and loose particles from the front and back of the product. Avoid touching the product's conductive surfaces and electronic components.

Installing new software

It may be necessary to upload new software (i.e. device firmware) to the VC-Grid if it appears to have a software-related fault or if you want to update to a newer software version.

Software for Martin™ products is available from the Martin website. The VC-Grid software can be installed from the P3 System Controller over the P3 data link. See the P3 System Controller user manual for software installation instructions.

Troubleshooting

Problem	Probable cause(s)	Remedy
Control is lost and pressing control button causes VC-Grid to show constant or flashing red status indication.	Error has occurred.	Check that system is correctly connected, set up and running. Hold control button pressed in until it turns blue, then release, to reboot VC-Grid. Restart P3 or DMX controller.
Product is completely dead.	No DC power to product.	Check 48 VDC power supply and cables
	Internal fault.	Disconnect from power. Do not attempt repairs yourself. Contact Martin™ Service or an authorized Martin™ service partner for assistance.
VC-Grid does not display as intended.	Bad 48 VDC power transmission.	Inspect connections and cables. Correct poor connections. Repair or replace damaged cables.
	Bad data transmission.	Inspect connections and cables. Correct poor connections. Repair or replace damaged cables.
	Incorrect mapping or addressing of products.	Check product address and controller settings.
	Product in installation is defective and is disturbing data transmission.	Substitute known good products one at a time until normal operation is regained. Have faulty product serviced by Martin™ Service.

Table 10: Troubleshooting

Specifications

Physical

VC-Grid 16x16 15

Pixel layout	16x16
Pixel pitch	15 mm (0.6 in.)
Length	240 mm (9.4 in.)*
Width	240 mm (9.4 in.)*
Height	15 mm (0.6 in.)
Weight	311 g (11.0 oz.)

*Including 5 mm (0.2in.) module-to-module gap

VC-Grid 8x8 25

Pixel layout	8x8
Pixel pitch	25 mm (1.0 in.)
Length	200 mm (7.9 in.)*
Width	200 mm (7.9 in.)*
Height	18 mm (0.7 in.)
Weight	140 g (4.9 oz.)

*Including 15 mm (0.6 in.) module-to-module gap

VC-Grid 8x8 30

Pixel layout	8x8
Pixel pitch	30 mm (1.2 in.)
Length	240 mm (9.4 in.)*
Width	240 mm (9.4 in.)*
Height	15 mm (0.6 in.)
Weight	157 g (5.5 oz.)

*Including 20 mm (0.8 in.) module-to-module gap

VC-Grid 8x8 60

Pixel layout	8x8
Pixel pitch	60 mm (2.4 in.)
Length	480 mm*
Width	480 mm*
Height	15 mm (0.6 in.)
Weight	500 g (17.6 oz.)

*Including 40 mm (1.6 in.) module-to-module gap

VC-Grid 4x4 60

Pixel layout	4x4
Pixel pitch	60 mm (2.4 in.)
Length	240 mm*
Width	240 mm*
Height	15 mm (0.6 in.)
Weight	123 g (4.3 oz.)

*Including 40 mm (1.6 in.) module-to-module gap

Control and programming

Control options	Martin P3 System Controller™ or DMX
Protocol detection	Automatic
Control modes	Pixel and module
Setting and addressing	P3 System controller or RDM-compliant DMX controller
Control resolution	16-bit (P3) or 8-bit (DMX) control of each color
Color and intensity calibration	Pixel-level
Video signal compliance	Martin P3™ proprietary video protocol
DMX compliance	USITT DMX512-A
RDM compliance	ANSI/ESTA E1.20
Firmware update	Via P3 System Controller

DMX channels used

VC-Grid 16x16 15 RGB, pixel mode (groups of 4 pixels)	192
VC-Grid 16x16 15 RGB, module mode	3
VC-Grid 8x8 25™ RGB, pixel mode	192
VC-Grid 8x8 25™ RGB, module mode	3
VC-Grid 8x8 25™ WW, pixel mode	64
VC-Grid 8x8 25™ WW, module mode	1
VC-Grid 8x8 25™ MW, pixel mode	64
VC-Grid 8x8 25™ MW, module mode	1
VC-Grid 8x8 25™ CW, pixel mode	64
VC-Grid 8x8 25™ CW, module mode	1
VC-Grid 8x8 30™ RGB, pixel mode	192
VC-Grid 8x8 30™ RGB, module mode	3
VC-Grid 8x8 60™ RGB, pixel mode	192
VC-Grid 8x8 60™ RGB, module mode	3
VC-Grid 4x4 60™ RGB, pixel mode	48
VC-Grid 4x4 60™ RGB, module mode	3

Control/user interface

Device status	Visual indication via LED display
Device test	Control pushbutton calls up local test patterns
Device reset	Control pushbutton

Video processing

- Brightness control
- Gamma correction and control
- Color temperature control
- Color gamut control
- Calibration processing
- Synchronization

Optics

Viewing angle	120° x 120°
Minimum LED lifetime	50 000 hours (to >70% luminous output)*

**Obtained under manufacturer's test conditions*

System Integration

P3 PowerPort 1500™	P/N 90721040
------------------------------	--------------

See www.martin.com for latest information

Construction

Base	Black FR4 circuit board
Protection rating	IP20
RoHS compliant	

Transparency through module (unmasked area)

VC-Grid 16x16 15	0%
VC-Grid 8x8 25	37%
VC-Grid 8x8 30	44%
VC-Grid 8x8 60	49%
VC-Grid 4x4 60	53%

Installation

Orientation	Any
Mounting method	Mounting holes in module
Minimum clearance around front surface	10 mm (0.4 in.)

See earlier in this manual for maximum number of VC-Grid modules that can be safely interconnected in one chain

Connections

Power & data input.	4-pin Molex male PCB connector
Power & data thru	4-pin Molex female PCB connector

Hot-plugging not supported

Electrical

Nominal input voltage	48 VDC
---------------------------------	--------

VC-Grid 16x16 15 RGB

Peak power consumption (at full intensity, full white)60 W
Peak current draw per module (at full intensity, full white)	1.3 A
Typical power consumption per module (with typical video content)20 W
Typical current draw per module (with typical video content)04 A

VC-Grid 8x8 25 RGB, WW, MW and CW

Peak power consumption (at full intensity, full white)30 W
Peak current draw per module (at full intensity, full white)07 A
Typical power consumption per module (with typical video content)10 W
Typical current draw per module (with typical video content)02 A

VC-Grid 8x8 30 RGB

Peak power consumption (at full intensity, full white)30 W
Peak current draw per module (at full intensity, full white)07 A
Typical power consumption per module (with typical video content)10 W
Typical current draw per module (with typical video content)02 A

VC-Grid 8x8 60 RGB

Peak power consumption (at full intensity, full white)30 W
Peak current draw per module (at full intensity, full white)07 A
Typical power consumption per module (with typical video content)10 W
Typical current draw per module (with typical video content)02 A

VC-Grid 4x4 60 RGB

Peak power consumption (at full intensity, full white)8 W
Peak current draw per module (at full intensity, full white)02 A
Typical power consumption per module (with typical video content)3 W
Typical current draw per module (with typical video content)01 A

Figures are per module and allow for cable in a chain with a total hybrid cable length of 50 m.

Figures for typical video content are indicative only and will vary. Peak figures must always be used for safety calculations.

Thermal

Cooling.	Convection
Maximum ambient temperature (Ta max.)	45° C (113° F)
Minimum ambient temperature (Ta min.)	-20° C (-4° F)

VC-Grid 16x16 15 RGB

Peak heat dissipation (calculated, at full intensity, full white)	206 BTU/hr.
Typical heat dissipation (calculated, with typical video content)	68 BTU/hr.

VC-Grid 8x8 25 RGB, WW, MW and CW

Peak heat dissipation (calculated, at full intensity, full white)	103 BTU/hr.
Typical heat dissipation (calculated, with typical video content)	34 BTU/hr.

VC-Grid 8x8 30 RGB

Peak heat dissipation (calculated, at full intensity, full white)	103 BTU/hr.
Typical heat dissipation (calculated, with typical video content)	34 BTU/hr.

VC-Grid 8x8 60 RGB

Peak heat dissipation (calculated, at full intensity, full white)	103 BTU/hr.
Typical heat dissipation (calculated, with typical video content)	34 BTU/hr.

VC-Grid 4x4 60 RGB

Peak heat dissipation (calculated, at full intensity, full white)	28 BTU/hr.
Typical heat dissipation (calculated, with typical video content)	11 BTU/hr.

Figure for typical video content is indicative only and will vary

Approvals



EU safety	EN 60950-1
EU EMC	EN 55103-1, EN 55103-2, EN 55022, EN 55024, EN 61000-3-2, EN 61000-3-3
US safety	UL 60950-1
US EMC	FCC Part 15 Class A
Canadian safety	CSA C22.2 No. 60950-1
Canadian EMC	ICES-003 Class A
Australia/NZ	C-Tick N4241

Accessories

Set of 8 VC-Grid/Strip 25 Lens Arrays Narrow (fits VC-Grid 8x8 25 only) P/N 91611540

Mounting accessories

VC-Grid/Strip 25 Mounting Frames, set of ten P/N 91611370

VC-Grid 15/30/60 Mounting Frames, set of ten P/N 91611560

Input cables

Hybrid Input Adapter Cable, 4-pin male XLR to PCB connector, 0.25 m (0.8 ft.) P/N 11840158

Hybrid Input Adapter Cable, 5-pin male XLR + two cable
tails to 4-pin female XLR, 0.25 m (0.8 ft.) P/N 11840171

Hybrid Input Adapter Cable, 5-pin male XLR + Tripix Power
IP66 to 4-pin female XLR, 0.25 m (0.8 ft.) P/N 11840194

VC-Grid to VC-Grid link cables

Hybrid link cable, PCB to PCB, 200 mm (7.9 in.) P/N 11840160

Hybrid link cable, PCB to PCB, 400 mm (15.7 in.) P/N 11840161

Hybrid link cable, PCB to PCB, 600 mm (23.6 in.) P/N 11840162

Hybrid link cable, PCB to PCB, 800 mm (31.5 in.) P/N 11840163

Hybrid link cable, PCB to PCB, 1000 mm (39.4 in.) P/N 11840157

Extension cables

Hybrid 4-pin XLR extension cable, 1 m (3.3 ft.) P/N 11821016

Hybrid 4-pin XLR extension cable, 2.5 m (8.2 ft.) P/N 11821017

Hybrid 4-pin XLR extension cable, 5 m (16.4 ft.) P/N 11821018

Hybrid 4-pin XLR extension cable, 10 m (32.8 ft.) P/N 11821019

Hybrid 4-pin XLR extension cable, 25 m (82.0 ft.) P/N 11821015

Output / throughput cables

Hybrid Output/Thru Cable, PCB to 4-pin female XLR, 0.25 m (0.8 ft.) P/N 11840159

Data Output/Thru Cable, 4-pin male XLR to 5-pin female XLR, 0.25 m (0.8 ft.) P/N 11840203

Hybrid cables carry both DC power and data over separate conductors.

Related Items

P3 PowerPort 1500™ P/N 90721040

P3-100™ System Controller P/N 90721010

P3-200™ System Controller P/N 90721020

P3-300™ System Controller P/N 90721060

P3-PC™ System Controller P/N 90721030

Tripix Power IP66™ Power Supply Unit P/N 90760330

See www.martin.com for latest information

Ordering information

VC-Grid™ 16x16 15 RGB P/N 90357540

VC-Grid™ 8x8 25 RGB P/N 90357010

VC-Grid™ 8x8 25 WW P/N 90357000

VC-Grid™ 8x8 25 MW P/N 90357030

VC-Grid™ 8x8 25 CW P/N 90357020

VC-Grid™ 8x8 30 RGB P/N 90357550

VC-Grid™ 8x8 60 RGB P/N 90357560

VC-Grid™ 4x4 60 RGB P/N 90357570

Specifications subject to change without notice. For the latest product specifications, see www.martin.com

FCC Compliance

This device complies with Part 15 of the FCC Rules. Operation is subject to the following two conditions: (1) This device may not cause harmful interference, and (2) this device must accept any interference received, including interference that may cause undesired operation.

Canadian Interference-Causing Equipment Regulations - *Règlement sur le Matériel Brouilleur du Canada*

This Class A digital apparatus meets all requirements of the Canadian Interference-Causing Equipment Regulations.
Cet appareil numérique de la classe A respecte toutes les exigences du Règlement sur le Matériel Brouilleur du Canada.



Disposing of this product

Martin™ products are supplied in compliance with Directive 2002/96/EC of the European Parliament and of the Council of the European Union on WEEE (Waste Electrical and Electronic Equipment), as amended by Directive 2003/108/EC, where applicable.

Help preserve the environment! Ensure that this product is recycled at the end of its life. Your supplier can give details of local arrangements for the disposal of Martin products.



www.martin.com • Olof Palmes Allé 18 • 8200 Aarhus N • Denmark
Tel: +45 8740 0000 • Fax +45 8740 0010