

## Overview

With the ABS AxLink Bus Strip (FG960) experience plug-and-play wiring, a power (PWR) status LED, and 12 VDC power inputs. Perfect for larger wiring runs the ABS simultaneously plugs in up to 10 AxLink terminals and connectors.



**FIG. 1** ABS AXLINK BUS STRIP

## Common Application

Ideal for combining up to 10 AxLink wiring runs.

## Specifications

The following table lists the specifications for the ABS AxLink Bus Strip.

SPECIFICATIONS	
Power	12 VDC, 7 A max.
Connectors	Ten - 4-pin, captive-wire AxLink connectors One - 2-pin, captive-wire power connector
LED	Power indicator (Red)
Enclosure	Metal with black matte finish
Dimensions (HWD)	1.14" x 12.00" x 1.27" 2.90 cm x 30.48 cm x 3.23 cm
Weight	6.70 oz (189.94 g)
Mounting Options	4" double-sided foam tape

Use the included double-sided tape to securely affix the unit to the surface.

## Installation and Wiring

### Wiring Guidelines

To determine the maximum distance allowed per gauge, use the following formula and refer to the table below:

$$1.5 / (\text{Power Consumption} \times \text{Resistance} \times 2) = \text{Distance (feet)}$$

WIRING GUIDELINES	
Gauge	Resistance
18 AWG	.00639
20 AWG	.0101
22 AWG	.0162
24 AWG	.0257

*Note: The maximum wiring lengths are based on a minimum of 13.5 volts available to the ABS. Preparing/connecting captive wires*

- Strip 0.25 inch of wire insulation off all wires.
- Insert each wire into the appropriate opening on the connector according to the wiring diagrams and connector types described in this section.
- Do not tighten the screws excessively; doing so may strip the threads and damage the connector.

### Wiring

- Connect wiring from the AxLink devices to connectors 2 through 10 on the ABS (FIG. 2). If the power LED lights when an AxLink cable is connected to the ABS, it indicates the AxLink cable has a local power supply. Unless that local supply is intended to power all devices connected to the ABS, disconnect it and insulate the wire connected to the PWR+ terminal.

*Note: All AxLink connectors on the ABS are connected together.*

- Connect the control system AxLink connector 1 on the ABS. As with the other AxLink devices in the system, connect all four wires to the ABS unless the Central Controller is using a local power supply.
- Connect the system power supply to the 2-pin connector on the ABS. The power LED should light, and all AxLink devices with PWR+ connected to the ABS should have power.

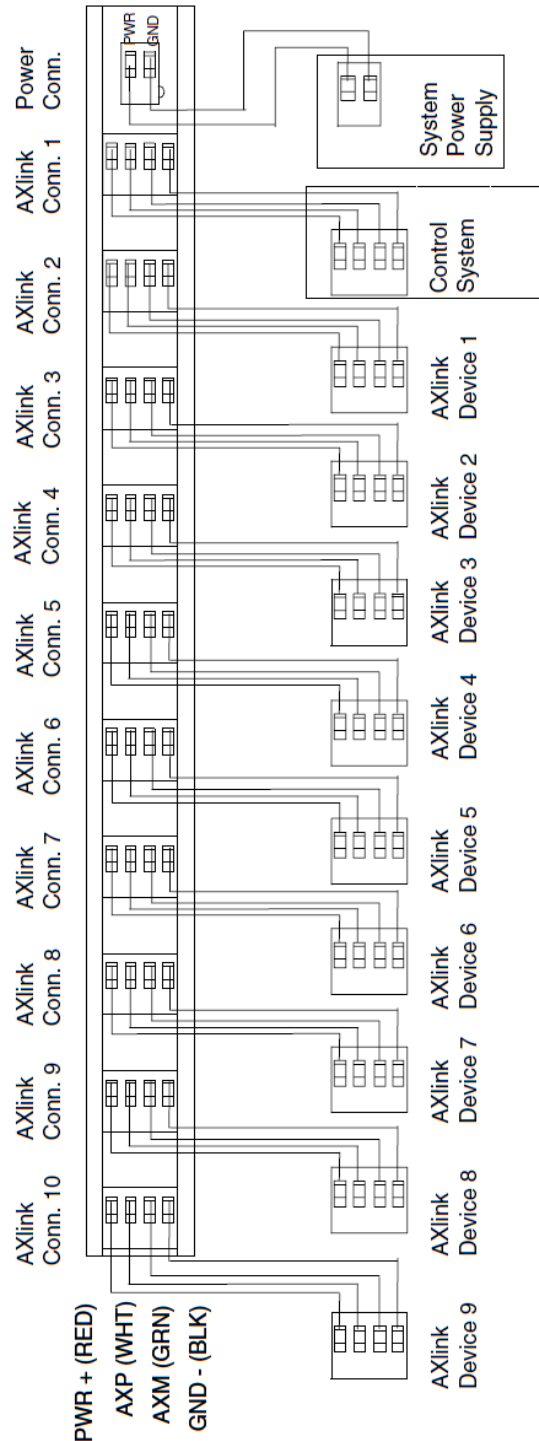

**FIG. 2** ABS WIRING DIAGRAM

*Note: If the AxLink devices have local power supplies, do not connect to the power terminal of the ABS via the PWR+ (Red).*

For additional information about the wiring distances between the ABS and a specific AxLink device, refer to the appropriate manual.

