

Overview

NOVARA 1000 Series ControlPads (FIG. 1) offer simplified device control with just the right mix of ease of use, simplicity of configuration, and cost effectiveness. NOVARA ControlPads are designed to be easily configurable allowing control of equipment by RS232 commands and IR.

The ControlPads are configured using the *NOVARA DCS1000 (Device Configuration Software)* software application, available for download from www.amx.com. Refer to the *NOVARA ControlPads Instruction Manual* (available at www.amx.com) for configuration instructions.

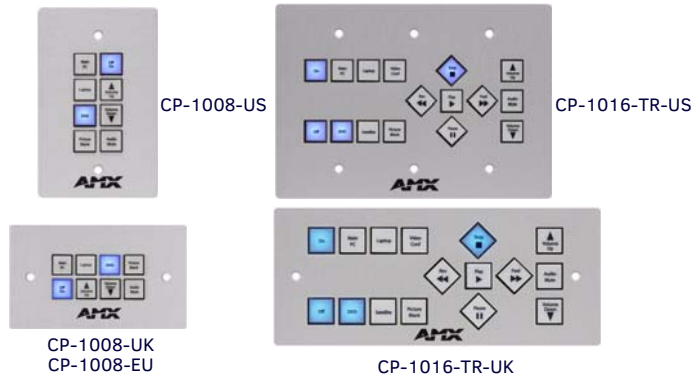

FIG. 1 NOVARA 1000 SERIES CONTROLPADS

The NOVARA 1000 Series of ControlPads include:

NOVARA 1000 SERIES CONTROLPADS		
Name	Description	Colors/FG#s
CP-1008-US 8-Button ControlPad	Fits 1-gang US conduit boxes. See Mounting Specifications for details.	<ul style="list-style-type: none"> White: FG1301-08-SW Black: FG1301-08-SB Brushed Aluminum: FG1301-08-SA
CP-1008-UK 8-Button ControlPad	Fits standard 2-gang UK conduit box sizes.	<ul style="list-style-type: none"> White: FG1301-08-KW Black: FG1301-08-KB Brushed Aluminum: FG1301-08-KA
CP-1008-EU 8-Button ControlPad	Fits standard 2-gang European conduit box sizes.	<ul style="list-style-type: none"> White: FG1301-08-EW Black: FG1301-08-EB Brushed Aluminum: FG1301-08-EA
CP-1016-TR-US 16-Button ControlPad	Fits 3-gang US conduit boxes See Mounting Specifications for details.	<ul style="list-style-type: none"> White: FG1301-16-SW Black: FG1301-16-SB Brushed Aluminum: FG1301-16-SA
CP-1016-TR-UK 16-Button ControlPad	Fits standard 3-gang UK conduit box sizes.	<ul style="list-style-type: none"> White: FG1301-16-KW Black: FG1301-16-KB Brushed Aluminum: FG1301-16-KA

Product Specifications

NOVARA 1000 SERIES CONTROLPADS	
Power Requirements:	<ul style="list-style-type: none"> Min: 250mA @ 12 VDC Max: 420mA @ 12 VDC (with all buttons illuminated to max brightness and 2 external devices attached to the RELAY 1/2 Ports in the ON state).
Button Layout:	<ul style="list-style-type: none"> 8 or 16 buttons Blue, backlit buttons with programmable feedback
Max number of events per ControlPad:	1330
Rear Panel Connectors:	<ul style="list-style-type: none"> RELAY 2 - Output port: can be used to control external devices (i.e. the AMX UPC-20+ Universal Power/Motor Controller - not included). <i>This is a current sink (not a voltage driver).</i> Max current sink - 100mA @12V. SHARED 12V - Common +12V. RELAY 1 - Output port: can be used to control external devices (i.e. the AMX UPC-20+ Universal Power/Motor Controller- not included). <i>This is a current sink (not a voltage driver).</i> Max current sink - 100mA @12V. RS232 OUT - RS232 output port: supports one-way RS-232 control (TX only). GND - Ground

NOVARA 1000 SERIES CONTROLPADS (CONT.)

Rear Panel Connectors (Cont.):	<ul style="list-style-type: none"> IR OUT - Connects to an IR Emitter to support one-way IR control (TX only). GND - Ground INPUT - Input detection: connects to an external switch (such as a PIR switch), for detecting a High to Low or Low to High state. -VE - Connects to the included 12V power supply (-). +VE - Connects to the included 12V power supply (+).
Top Panel Connector:	1 USB device configuration port.
Supported Baud Rates:	1200 - 115200
Dimensions (HWD):	<ul style="list-style-type: none"> CP-1008-US: 4.685" x 2.913" x 1.059" (11.9 cm x 7.4 cm x 2.7 cm) CP-1008-UK: 3.386" x 5.787" x 1.059" (8.6 cm x 14.7 cm x 2.7 cm) CP-1008-EU: 3.150" x 5.984" x 1.059" (8.0 cm x 15.2 cm x 2.7 cm) CP-1016-TR-US: 4.724" x 6.693" x 1.059" (12 cm x 17 cm x 2.7 cm) CP-1016-TR-UK: 3.385" x 8.140" x 1.170" (8.6 cm x 20.7 cm x 3 cm)
Weight:	<ul style="list-style-type: none"> CP-1008-US: 0.30 lbs (136 g) CP-1008-UK: 0.35 lbs (159 g) CP-1008-EU: 0.35 lbs (159 g) CP-1016-TR-US: 0.55 lbs (249 g) CP-1016-TR-UK: 0.65 lbs (295 g)
Included Accessories:	<ul style="list-style-type: none"> Button Kit - includes acetate sheet with 50 pre-cut button label inserts and clear plastic Key Caps External 12V Power Supply (57-1301-SA)
Certifications:	<ul style="list-style-type: none"> IEC 60950 FCC/CE RoHS compliant

Mounting Specifications

Refer to the Product Specifications table above for dimensions. Dimensional drawings are available in the *NOVARA ControlPads Instruction Manual*.

Minimum Internal Clearance for US Conduit Boxes

To ensure a proper fit with sufficient clearance, US-style NOVARA ControlPads require the following minimum internal dimensions within the conduit box:

- US 1-Gang (HWD): 2.9" x 2.1" x 1.6" (7.36 cm x 5.3 cm x 4 cm)
- US 3-Gang (HWD): 2.9" x 5.6" x 1.6" (7.36 cm x 14.2 cm x 4 cm)

These minimum interior dimensions will maintain a minimum .050" (.127 cm) clearance around the NOVARA unit.

Wiring and Connections

ControlPads - Rear Panel Connectors

FIG. 2 shows the rear panel connectors of the NOVARA ControlPads:

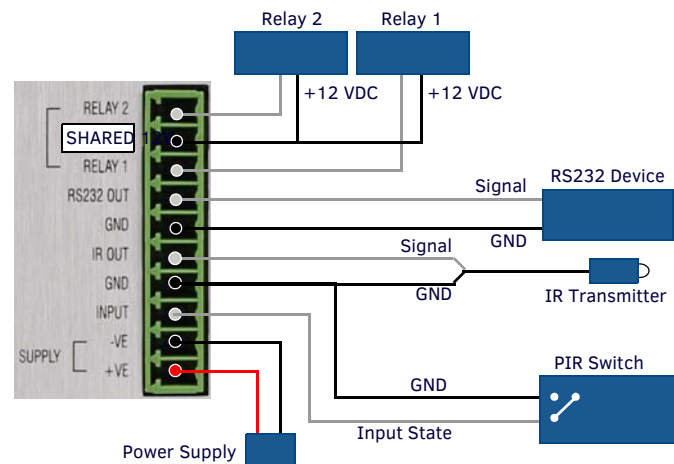

FIG. 2 NOVARA CONTROLPADS - REAR PANEL CONNECTORS

Notes on "Relay 1/2" Connectors

The "Relay 1" and "Relay 2" Output ports each act as a switch to GND and are rated at 100 mA @ 12 VDC. These Output ports are used to control external devices (i.e. the PC1 Power Controller or AMX UPC-20+ Universal Power/Motor Controller - not included).

These Output ports do not function like "Relay" ports on other AMX equipment:

- The Relay 1 and Relay 2 output ports are *current sinks*, not voltage drivers, they switch the ports to GND.
- The "SHARED +12V" connector is common +12 VDC (*not Ground*).
- These Output ports use 5V logic, but can handle up to 12V on the input without harm - at higher voltages you run a higher risk of surge damage.

Note: The Relay ports are for external relay control only.

Connecting the Power Supply

- Connect the White strip lead to the +VE terminal on the ControlPad,
- Connect the Black strip lead to the -VE terminal.

Note: If using an AMX Power Supply other than the one supplied, be aware that the Power Supply polarities on Novara ControlPads are opposite to that of other AMX equipment. This is not an issue if using the included power supply.

When the ControlPad is powered up or a program downloaded, button #2 will flash for 2 seconds then extinguish to indicate that the ControlPad has passed it's self-test.

USB Program Port

To download a program to the ControlPad, connect the USB Programming cable to the ControlPad USB Port on the top panel, and the USB Port of the PC (FIG. 3).

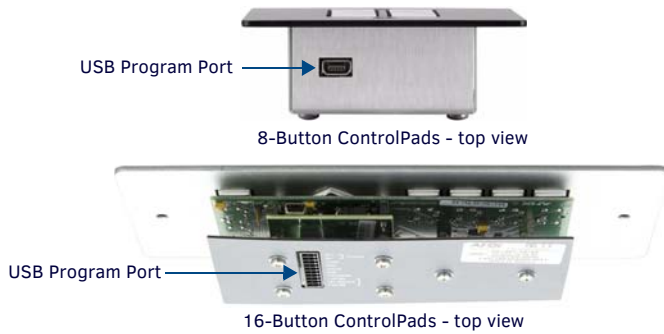

FIG. 3 USB PROGRAM PORT

NOVARA 1000 Series ControlPads are configured using the NOVARA DCS1000 Device software application (available for download at www.amx.com).

Button Labeling

NOVARA ControlPads come with a set of clear plastic Key Caps, which are designed to fit tightly over the pushbuttons, and allow you to place a label on each button according to the requirements of your particular installation.

NOVARA ControlPads also come with a pre-printed acetate sheet with a range of 50 (pre-cut) button label inserts. The button labels provided will accommodate most installations, but it is also possible to print your own button labels on acetate for custom button labeling.

Installing Acetate Button Labels and Key Caps - READ THIS FIRST!

1. Punch out the desired Button Label from the included acetate sheet.
If you have printed your own custom button labels on acetate, cut each button label to fit inside the Key Caps.
 - Custom button labels must be cut to a **1.20cm (0.472") square** to fit securely inside the Key Caps.
 - The thickness of the acetate used must not exceed **.004" (0.10 mm)**.
2. Place the Key Cap face-down, and insert the Button Label into the bottom of the Key Cap (FIG. 4).

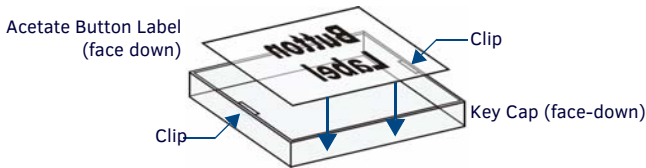

FIG. 4 PLACING A BUTTON LABEL INSIDE A KEY CAP

- Orient the Button Label inside the Key Cap so that the two clips are located on the left and right sides of the readable text on the Button Label, as indicated in FIG. 4.
- Be sure to place the Button Label face-down inside the Key Cap (see FIG. 4), otherwise the label will be seen in reverse once the Key Cap is installed.

3. Install the Key Cap on the pushbutton (FIG. 5):

Key Cap - tilted so that the bottom of the Cap is placed on the bottom of the pushbutton first

At this point, do not allow the clips on the sides of the Key Cap to engage

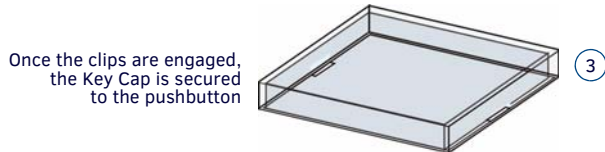
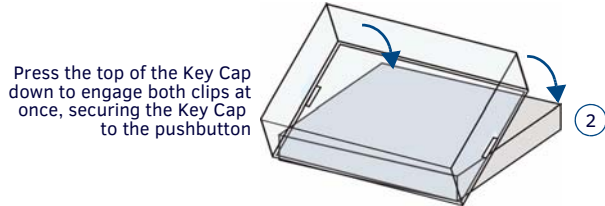
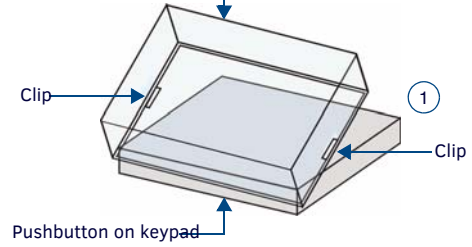

FIG. 5 PLACING A BUTTON LABEL INSIDE A KEY CAP

Note: Verify that the vertical orientation of the Button Label is correct relative to the keypad.

- Gently press the bottom of the Key Cap (no clip) onto the pushbutton. *Do not allow the clips on either side to engage.*
- With the bottom of the Key Cap secured, gently press the top of the Key Cap. This action will engage both clips simultaneously, and the Key Cap will snap into place on the push button.

Note: Be careful to follow these procedures closely - the bottom of the Key Cap must be installed on the pushbutton before the Key Cap clips engage, or there is a risk of the button being misaligned.

Removing the Key Caps requires additional steps - refer to the *NOVARA ControlPads Instruction Manual* for details on Replacing Button Labels/Key Caps.

Additional Documentation

Refer to the *NOVARA ControlPads Instruction Manual* (available at www.amx.com) for additional installation/wiring details, instructions on using the NOVARA DCS1000 software application to configure the devices, and RS232 control instructions.

