

Overview

The Mio Modero Prestige (FG5798-01xx, single style; FG5798-02xx, double style; xx indicates color selection) provides a wide range of control capabilities in the form of keypads that are as adept as they are elegant. Each device is available as single style (8 button max) or double style (16 button max).

Use *KeypadBuilder* software to program these devices. The application and documentation are available from www.amx.com.

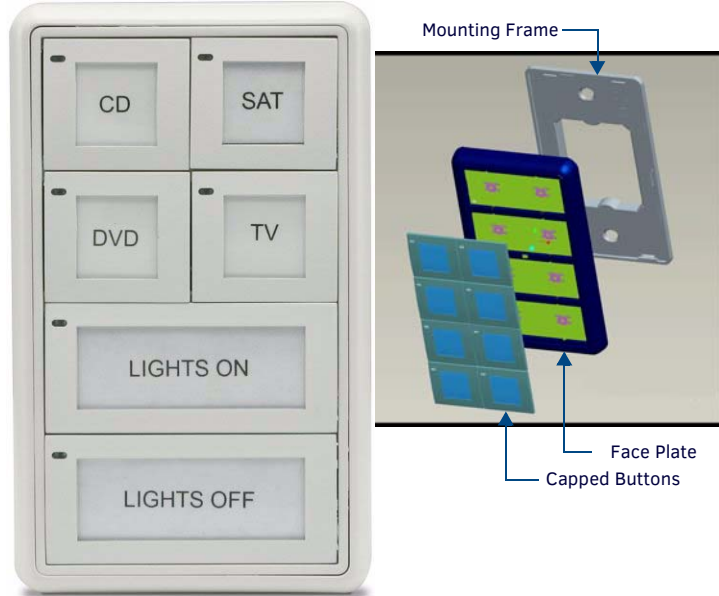

FIG. 1 MIO MODERO PRESTIGE

Specifications

The Mio Modero device family keypad specifications are as follows:

Specifications	
Models Available	<ul style="list-style-type: none"> MIO-PRESTIGE-S (White): FG5798-01WH MIO-PRESTIGE-S (Black): FG5798-01BL MIO-PRESTIGE-S (Beige): FG5798-01BG
Power:	12 VDC, 70 - 230 mA (range depending on device type and number of buttons)
Front Panel Components:	<ul style="list-style-type: none"> Pushbuttons - a maximum of 8 buttons on the single style and 16 buttons on the double style, with a direct LED light.
Rear Panel Components:	<ul style="list-style-type: none"> DIP switch - 8 position mini DIP switch used to set the device address for the keypad on the AXlink Bus. Wiring connection - 4 pin 3.5mm Phoenix AXlink connector.
Dimensions (HWD):	<ul style="list-style-type: none"> Single style - 4.46" x 2.71" x .57" (113.28mm x 68.83mm x 14.48mm) Double style - 4.46" x 4.39" x .57" (113.28mm x 111.51mm x 14.48mm)
Weight (range):	.25 lbs (.11 kg) - .50 lbs (.23 kg) Style and number of buttons will decide weight.
Operating Environment:	<ul style="list-style-type: none"> Operating Temperature: 0° to 50° C (32° to 122° F) Storage Temperature: -10° to 70° C (14° to 158° F)
Mounting:	Mounts into US and a majority of International single gang back boxes.
Included Accessories:	<ul style="list-style-type: none"> Single style mounting kit (KA-5795-01) Double style mounting kit (KA-5795-02) Mylar kit - Sheets of common menu items and icons for creating inserts for single and double buttons. Available in either black, white, or beige <ul style="list-style-type: none"> 91-5798-01WH = White 91-5798-01BG = Beige 91-5798-01BL = Black Phoenix Connector (41-5045)
Optional Accessories:	<ul style="list-style-type: none"> Accent Frame (for some larger wallboxes): <ul style="list-style-type: none"> Prestige Colors (xx indicates color selection) - FG5795-08xx (single button); FG5795-09xx (double button) Custom buttons: <ul style="list-style-type: none"> Prestige Colors (xx indicates color selection) - FG5798-05xx (4 single buttons); FG5798-06xx (2 double buttons)

Installation

Note: Before touching the device, discharge the static electricity from your body by touching a grounded metal object.

The basic front and rear components of the Mio Modero are as follows:

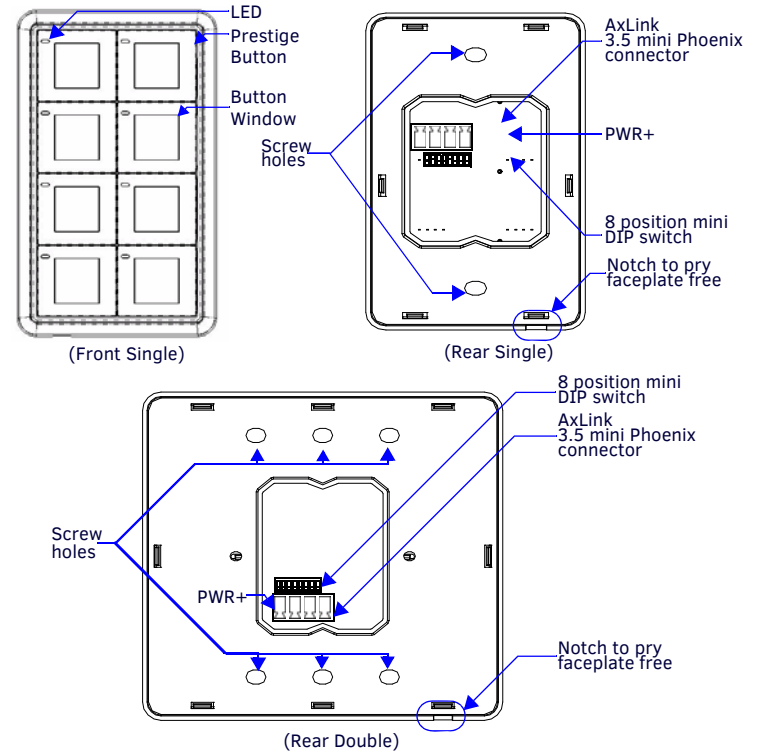

FIG. 2 MIO MODERO FRONT AND REAR COMPONENTS

Changing Buttons

The Mio Modero Prestige ships with sheets of common menu items and icons for creating inserts for single and double buttons.

1. If connected, disconnect the power supply.
2. Place a flathead screwdriver in the notch at the bottom right of the Mio Modero, and pry the faceplate from the mounting frame.
3. On the back of the faceplate locate the button access points, outlined with white circles. Using a straightened paper clip, poke through the button access points until the buttons pop free.
4. The Prestige buttons are comprised of three parts, the frame, window, and back insert. From the front of the button, use your thumb to poke the window and back insert out of the frame. See FIG. 3.

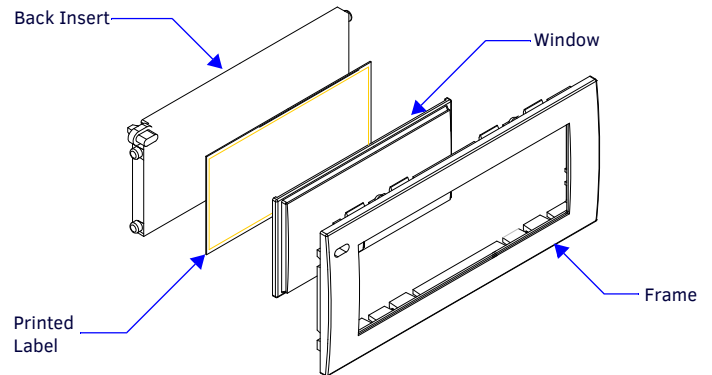

FIG. 3 PRESTIGE BUTTON COMPONENTS

5. Snap the window into the frame and then place the printed labels inside each button.
6. Snap the back insert to the window and frame.
7. Insert the buttons into their proper location on the faceplate.
8. If the power supply was disconnected in **Step 1**, reconnect and return power to the device.
9. Snap the faceplate on the mounting frame.

Be certain to reprogram the Mio Modero to match the new button arrangement; use KeypadBuilder to assign the locations. See the *KeypadBuilder Instruction Manual* available at www.amx.com.

Setting the AxLink Device Number

1. If connected, disconnect the power supply.
2. Locate the 8-position Device DIP switch on the rear panel.(FIG. 4).
3. Set the DIP switch according to the switch values shown below.

Switch	1	2	3	4	5	6	7	8
Value	1	2	4	8	16	32	64	128

The device number is set by the total value of DIP switch positions that are ON (up). As an example, the DIP switch in FIG. 4 defines device number 129 (1+128=129).



FIG. 4 EXAMPLE DEVICE DIP SWITCH SET TO 129

If you later change the device number, remove and reconnect the AxLink power connector to enter the new device number into memory.

Note: Use the DipSwitch2 software application (available at www.amx.com) to calculate dip switch position values.

Wiring

The Mio Modero uses a four-pin mini AxLink connector for power and data.

Caution: Do not connect power to the Mio Modero until the wiring is complete.

Preparing captive wires

You will need a wire stripper, and flat-blade screwdriver to prepare and connect the captive wires.

1. Strip 0.25 inch (6.35 mm) of wire insulation off all wires.
2. Insert each wire into the appropriate opening on the connector according to the wiring diagrams and connector types described in this section.
3. Turn the flat-head screws clockwise to secure the wires in the connector.

Note: Do not over-torque the screws; doing so can bend the seating pins and damage the connector.

Wiring guidelines

The Mio Modero requires 12 VDC power to operate properly. The necessary power is supplied via the AxLink cable. The maximum AxLink wiring distance is determined by power consumption, supplied voltage, and the wire gauge used for the cable. The following table lists wire sizes and the maximum lengths allowable based on the maximum power consumption rating of 170 mA.

Wiring Guidelines at 170 mA	
Wire Size	Maximum Wiring Length
18 AWG	690.42 feet (210.43 m)
20 AWG	436.80 feet (133.13 m)
22 AWG	272.33 feet (83.00 m)
24 AWG	171.66 feet (52.32 m)

The maximum wiring lengths for using AxLink power are based on a minimum of 13.5 volts available. If the distance is greater than what is listed in the table, consult the *Mio Modero Device Family Instruction Manual* for wiring with external power sources.

Connecting the Wiring

Caution: If using power from AxLink, disconnect the wiring from the control system before wiring the Mio Modero.

AxLink Data and Power Connections

Connect the control system's AxLink connector to the AxLink connector on the rear panel of the Mio Modero for data and 12 VDC power as shown in FIG. 5.

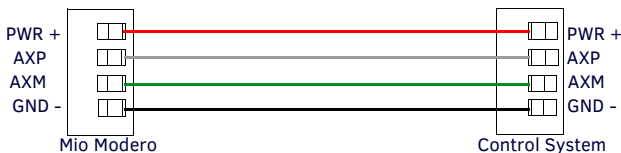

FIG. 5 AXLINK STRAIGHT-THRU WIRING

Mounting Procedures

AMX recommends mounting the Mio Modero in a standard one-gang wallbox, a conduit box per NEC specs section 370, with a minimum internal clearance of 2-5/8" x 1-3/4" x 1-5/8" (HWD), but it is possible to mount the Mio Modero to a podium without a wallbox. More installation details are available in the *Mio Modero Device Family* instruction manual.

Wallbox Mounting

1. Use the cutout dimension for the wallbox to cutout the install surface for the Mio Modero.
2. Confirm that the terminal end of the AxLink cable is disconnected, and not receiving power.
3. If the faceplate is connected to the mounting frame, place a flathead screwdriver in the notch at the bottom right of the Mio Modero, and pry the faceplate from the mounting frame.
4. Connect the AxLink power supply. The connector passes through the center of the mounting frame and connects to the board. The connection is illustrated in FIG. 2.

5. Place the mounting frame on the wallbox; align the screw holes with the mounting holes on the panel, and fasten the mounting frame to the wallbox using the screws supplied.

Note: Do not over-tighten the screws when mounting the mounting frame. The device should be flush with mounting surface.

6. Attach the faceplate to the mounting frame first at the top and swing it to the bottom. See FIG. 6

Podium Mounting

1. The necessary area for the mounting frame opening is 2.00 x 2.25; cutout the mounting frame install surface to accommodate the Mio Modero.

2. Confirm that the terminal end of the AxLink cable is disconnected, and not receiving power.

3. If the faceplate is connected to the mounting frame, place a flathead screwdriver in the notch at the bottom right of the Mio Modero, and pry the faceplate from the mounting frame.

4. With the mounting frame resting in the cutout area, drill the mounting holes into the flat surface.

Note: Do not over tighten the screws when mounting the mounting frame. The device should be flush with mounting surface.

5. Connect the AxLink power supply. The connector passes through the center of the mounting frame and connects to the board. The connection is illustrated in FIG. 2.

6. Attach the faceplate to the mounting frame first at the top and swing it to the bottom. See FIG. 6.

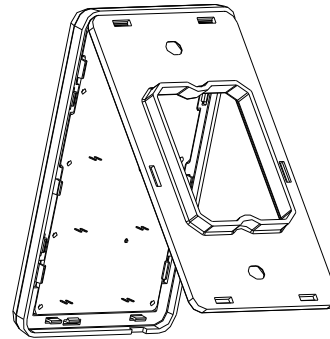

FIG. 6 ATTACHING THE FACEPLATE TO THE MOUNTING FRAME

Programming The Mio Modero

KeypadBuilder

Most functionality of the Mio Modero is handled using the application, *KeypadBuilder*. Go to www.amx.com for the *KeypadBuilder Instruction Manual*.

There are a select number or SEND_COMMANDs the Mio Modero recognizes. For a full list and descriptions, consult the *Mio Modero Device Family Instruction Manual*.

