

MAC Allure™ Profile

User Guide



Martin[®]
by HARMAN

User Documentation update information

Any important changes in the MAC Allure Profile User Guide are listed below.

Revision A

First version released. Covers MAC Allure Profile firmware version 1.0.0

©2018 HARMAN PROFESSIONAL DENMARK ApS. All rights reserved. Features, specifications and appearance are subject to change without notice. HARMAN PROFESSIONAL DENMARK ApS and all affiliated companies disclaim liability for any injury, damage, direct or indirect loss, consequential or economic loss or any other loss occasioned by the use of, inability to use or reliance on the information contained in this document. Martin is a registered trademark of HARMAN PROFESSIONAL DENMARK ApS registered in the United States and/or other countries.

HARMAN PROFESSIONAL DENMARK ApS, Olof Palmes Alle 44, 8200 Aarhus N, Denmark
HARMAN PROFESSIONAL SOLUTIONS U.S., 8500 Balboa Blvd., Northridge CA 91329, USA

www.martin.com

Contents

Introduction	4
Operating the fixture	4
Effects	5
Shutter and strobe effects	5
Dimming	5
Color temperature control	5
Virtual color wheel	5
Full-fixture color mixing	5
Individual pixel color mixing	5
P3 video	6
Control priority	6
Rotating gobos	6
Gobo overlays	7
Beam effect (rotating prism)	7
Iris	7
Focus and zoom	7
Pan and tilt	8
Pre-programmed FX	8
Control panel	9
Control options	11
DMX	11
RDM	12
P3 video	12
Fixture setup	13
Fixture ID	13
Personality	13
Factory defaults	14
Custom settings	14
Fixture information readouts	15
DMX signal monitoring	15
Test sequences	15
Manual control	15
Service utilities	16
Calibration	16
Installing firmware	16
Adjusting settings via DMX	19
Resetting	19
Illuminating the display	19
Control menu setting overrides	19
Changing calibration offsets using DMX	19
DMX protocol	21
Basic DMX Mode	21
Extended DMX Mode	27
FX: pre-programmed effects	28
Control panel menus	29
Service and display messages	33
Warning messages	33
Error messages	34

Introduction



Warning! Before installing, operating or servicing the MAC Allure Profile, read the latest version of the product's Safety and Installation Manual, paying particular attention to the Safety Precautions section. The Safety and Installation Manual is supplied with the fixture. The latest version is also available for download from the MAC Allure Profile area of the Martin website at www.martin.com.

This User Guide is a supplement to the Installation and Safety Manual that is supplied with the MAC Allure Profile. Both these documents are available for download from the MAC Allure Profile area of the Martin® website at www.martin.com. This User Guide contains information that is mainly of interest for lighting designers and operators, whereas the Safety and Installation Manual contains important information for all users, especially installers and technicians.

We recommend that you check the Martin website regularly for updated documentation, because we publish revised versions each time we can improve the quality of the information we provide and each time we release new firmware with changes or new features. Each time we revise this guide we list any important changes on page 2 so that you can keep track of updates.

Operating the fixture

Before applying power to or operating the MAC Allure Profile:

- Read the 'Safety Information' section of the fixture's Safety and Installation Manual.
- Check that the installation is safe and secure.
- Check that the base is fastened securely so that the torque reaction when the head moves will not cause the base to move.
- Check that the head tilt lock is released.
- Be prepared for the fixture to light up suddenly. Check that no-one is looking at the fixture from close range.
- Be prepared for the head to move suddenly. Check that there will be no risk of collision with persons or objects.

The MAC Allure Profile does not have an On/Off switch. To apply power to the fixture, apply power to the power input cable.

Effects

This section gives details of the effects available in the MAC Allure Profile. See the DMX protocol table on page 21 for a list of channels and commands used to control the effects via DMX.

Where fine control is available, the main control channel sets the first 8 bits (the most significant byte or MSB), and the fine channels set the second 8 bits (the least significant byte or LSB) of the 16-bit control byte. In other words, the fine channel works within the position set by the coarse channel.

When the MAC Allure Profile is included in a Martin P3™ video system, the fixture provides seven pixels that can be controlled from a P3 video controller and media server or other video source.

Shutter and strobe effects

The MAC Allure Profile's electronic shutter effect provides instant blackout and snap open as well as regular or random strobe effects with variable speed from approx. 2 Hz to 20 Hz.

Dimming

Smooth 0-100% overall dimming is available with 16-bit control resolution.

Color temperature control

Color temperature control is available on a dedicated CTC channel. You can adjust the fixture's color temperature from 2000 K to 10 000 K in 50 K steps.

Virtual color wheel

The MAC Allure Profile offers 36 color presets, almost all of which are Lee-referenced. Presets are controlled using a virtual color wheel control model. Colors can be applied as split colors or in full-color steps. Virtual color wheel scrolling lets you applying color presets sequentially with control of speed and order of color sequence. Color presets can also be applied at random at fast, medium or slow speed.

Full-fixture color mixing

16-bit RGB control of the overall output of the fixture is available on six DMX channels in both Basic and Extended DMX modes.

Individual pixel color mixing

See Figure 1. The MAC Allure Profile's beam can be divided into seven segments that are numbered as shown in Figure 1. You can use the focus channel to adjust the definition of the segments from sharply outlined to softly merged.

Individual 16-bit RGB control of each of the fixture's seven segments is available on DMX channels 27-68 in Extended DMX mode.

Segments are always treated as individual pixels in a P3 video system.

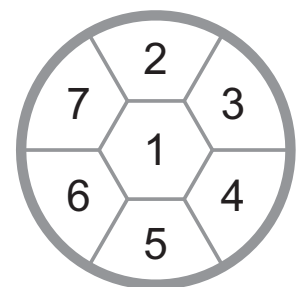

Figure 1: Pixel segments

P3 video

The MAC Allure Profile is compliant with the Martin P3™ distributed video system. If you add the fixture to a P3 installation, the P3 controller will treat the fixture's seven segments as seven pixels regardless of which DMX mode the fixture is set to.

P3 control lets you match the color and intensity of MAC Allure Profile fixtures precisely and instantly with other P3 video display fixtures or panels in an installation.

Control priority

The MAC Allure Profile auto-senses and responds correctly to whichever control protocol it is receiving: DMX and/or RDM via standard DMX cable, DMX and/or RDM via Art-Net or streaming ACN over Ethernet cable, or P3 video.

If the fixture is connected to both DMX and P3 video signals, The P3 DMX channel (channel 21) lets you determine which signal should take priority. You can also crossfade, which means that you can superimpose DMX data with variable opacity from 0% to 100% onto the P3 video output that is being displayed on the fixture's pixels.

Rotating gobos

The rotating gobo wheel in the MAC Allure Profile has six rotating gobos that can be selected, indexed (positioned at an angle), rotated continuously, and shaken (bounced). The wheel can also be scrolled continuously or shaken. Gobo selection and control type (indexing, continuous gobo rotation, gobo shake or continuous gobo wheel scrolling) are selected on channel 6. Depending on what is selected on this channel, the gobo indexed angle or gobo rotation speed are set on channels 7 and 8, where 16-bit control is available.

The standard gobos are shown in the correct order in Figure 2. All gobos are interchangeable. The MAC Allure Profile Safety and Installation Guide contains details.

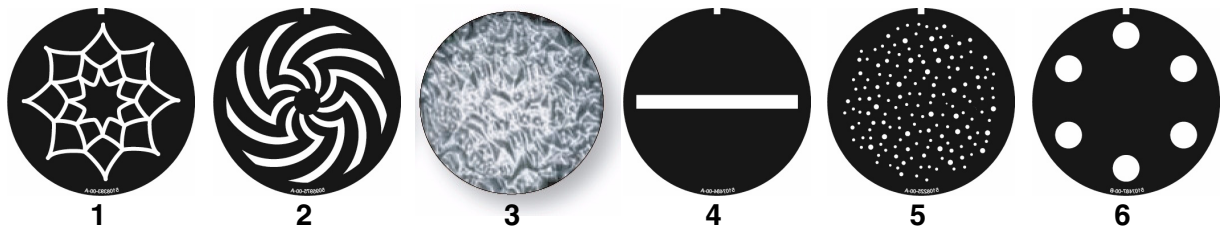

Slot - Gobo	Part number
1. Spidey	P/N 5108393-00
2. Whirlwind	P/N 5095975-00
3. Limbo (glued in holder)	P/N 62327298
4. Bar	P/N 5107484-00
5. Dots in Space	P/N 5108225-00
6. Phone Dial	P/N 5107487-00

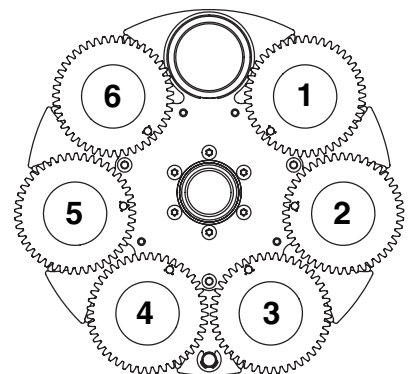

Gobo wheel seen from front glass side

Figure 2: Rotating gobos installed as standard

Gobo overlays

See Figure 3. The rotating gobo wheel features a static gobo overlay plate that provides morphing effects on Gobo 2 and Gobo 3.

- Morphing between Gobo 2 (Whirlwind) and the Gobo 2 overlay can help create the illusion of a spinning wheel or propeller in a movie, for example.
- Morphing between Gobo 3 (Limbo) and the Gobo 3 overlay simply lets you crossfade between two gobos with very different looks.

To morph between a rotating gobo and its overlay, use the focus adjustment DMX channel.

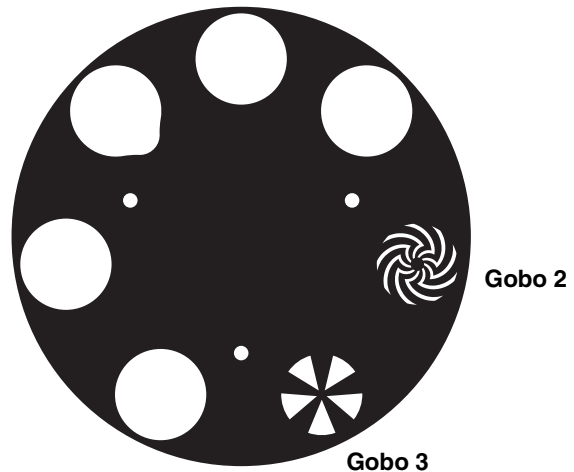

Figure 3: Gobo overlays

Beam effect (rotating prism)

The four-facet prism can be applied at indexed angles or rotated with variable direction and speed.

Iris

The iris diameter can be varied continuously from fully open to closed. Opening and closing pulse effects with variable speed are also available.

Focus and zoom

Adjusting focus lets you vary the sharpness of projected images at different distances. It also lets you morph between Gobos 2 and 3 and their corresponding overlays.

The MAC Allure Profile's zoom lens varies the focused beam angle from 12° to 36° with the standard lens installed. Wide zoom angles allow sharp focus on projection surfaces close to the fixture. At narrower zoom angles, sharp focus is only possible further from the fixture.

Long-range focus can always be set to infinity

Zoom/focus linking

Focus varies with zoom angle, but focus can be linked to zoom so that it automatically adjusts to match changes in zoom angle. Focus on rotating gobos matches zoom closely, while focus on Gobo 2 and 3 overlays matches zoom best in the center of the zoom range and slightly less precisely at the two extremes of the zoom range.

Linked zoom/focus works within 3 distance ranges: close-, medium- and long-range. The ranges are as follows (figures are approximate):

- Close (5 - 10 meters / 16.5 - 33 ft.)
- Medium (10 - 20 meters / 33 - 66 ft.)
- Long (20 meters - infinity / 66 ft. - ∞)

To link zoom and focus, select a distance range using the Fixture Control/Settings DMX channel or **FOCUS TRACKING** in the control panel **PERSONALITY** menu. Then adjust focus to obtain the required degree of sharpness. Linking is now enabled and focus will auto-adjust to match changes in zoom angle.

Pan and tilt

Coarse and fine pan and tilt control are available in both Basic and Extended DMX modes.

Pre-programmed FX

The MAC Allure Profile offers a range of pre-programmed effect macros that we simply call FX. See “FX: pre-programmed effects” on page 28.

The built-in FX give instant access to complex dynamic effects with no need for time-consuming programming at the controller.

Depending on how you set up DMX/P3 crossfading on the P3 channel (DMX channel 21), you can superimpose FX over any P3 video that the fixture is displaying.

Note that firmware updates can add new FX to those that are available in the fixture. If new FX are added, the change will be mentioned in the release notes and a new revision of this User Guide will be made available for download in the MAC Allure Profile area of the Martin website at www.martin.com

Control panel

You can configure individual fixture settings (such as the MAC Allure Profile's DMX address), read out data, execute service operations and view error messages using the fixture's backlit graphic display and control panel.

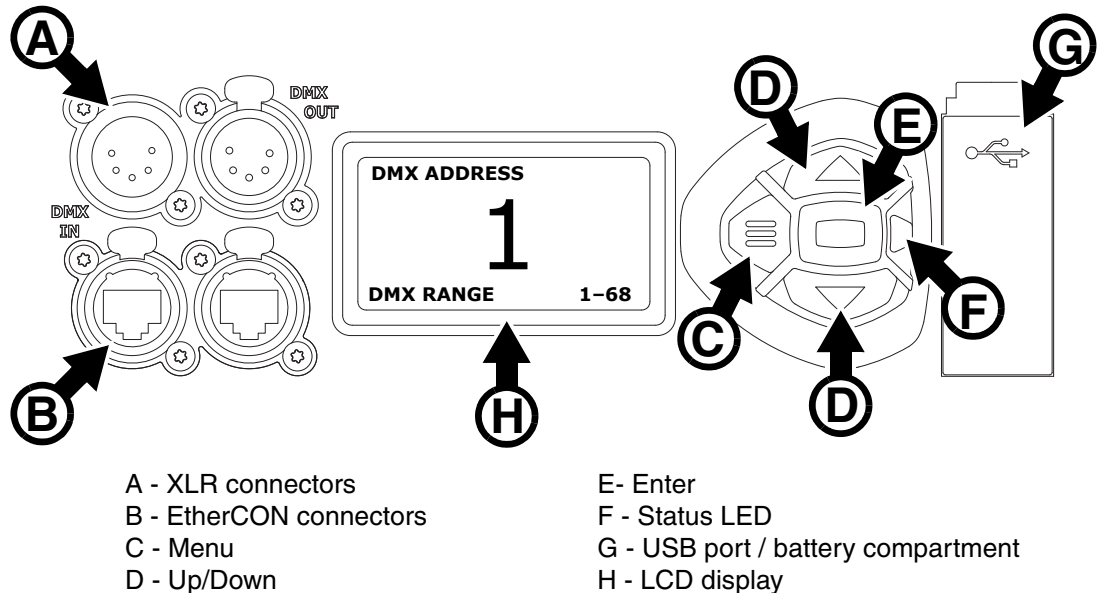

Figure 4: Display and control panel

When the MAC Allure Profile is powered on, it first boots and resets, then it displays its DMX address (or its fixture ID number, if one has been set) and any status messages (see page 33) in the display **A**.

The display can be set to automatically rotate to match standing or hanging fixture orientation in the **PERSONALITY** → **DISPLAY** menu or the Shortcuts menu (see "Shortcuts" on page 10).

Using the control panel

- Press the Menu button **C** or Enter button **E** to access the menus.
- Use the Up and Down buttons **D** to scroll up and down menus.
- Press the Enter button **E** to enter a menu or make a selection.
- The currently selected item in a menu is indicated by a star ✱.
- Press the Menu button **C** to step backwards through the menus.

Status LED

The LED **F** next to the control buttons indicates fixture status by showing a color and DMX status by flashing or lighting constantly:

- **GREEN**: All parameters normal.
- **AMBER**: Warning (service interval exceeded, for example).
If **ERROR MODE** is set to **Normal**, the warning message will be shown in the display. If **ERROR MODE** is set to **Silent**, the display must be activated by pressing the Enter button **C** to display the warning message.
- **RED**: Error detected.
If **ERROR MODE** is set to **Normal**, the error message will be shown in the display. If **ERROR MODE** is set to **Silent**, display the error message BY GOING TO NORMAL OR SERVICE - ERROR LIST.
- **FLASHING**: No DMX signal detected.
- **CONSTANT**: Valid DMX signal detected.

The status LED is only active when the display is active. If the display enters sleep mode, the LED will also sleep.

Battery power

The MAC Allure Profile's onboard battery gives access to the most important functions in the control panel when the fixture is not connected to AC power. The following functions are available on battery power:

- DMX address
- DMX control mode (Basic/Extended)
- Fixture ID
- All personality settings (pan/tilt, cooling, fan clean mode, dimming curve, DMX reset, parameter shortcuts, all display settings, error mode)
- Default settings
- Information (Power On Hours and Power Cycles counters, Software version)
- Error list

To activate the display when the fixture is not connected to power, press the Menu button **C**. Press again to enter the menus. The display extinguishes after 10 seconds with no user input and the control panel is de-activated after 1 minute with no user input. Press the Menu button **C** again to re-activate.

Shortcuts

If you hold the Menu button **C** pressed in for 2 - 3 seconds, a shortcut menu with the most important commands appears. Select a command with the Up and Down buttons **D** and press the Enter button **E** to activate, or press the Menu button **C** again to cancel.

- **RESET ALL** resets the whole fixture
- **ROTATE DISPLAY** rotates the MAC Allure Profile display 180°.

Settings stored permanently

The following settings are stored permanently in the fixture memory and are not affected by powering the MAC Allure Profile off and on or by updating the fixture software:

- DMX address
- DMX control mode (Basic/Extended)
- Fixture ID
- All personality settings (pan/tilt, cooling, dimming curve, DMX reset, parameter shortcuts, all display settings, error mode, etc.)
- Resettable counters
- Service settings (adjustment, calibration)

These settings can be returned to factory defaults using the control menus or via DMX.

Service mode

Holding the Menu and Enter buttons **C** and **E** both pressed in while powering the fixture on puts the fixture into service mode, in which pan and tilt are disabled and a **SERV** warning appears in the display. Service mode removes the risk of unexpected head movement during service adjustments.

Cycling power and allowing the fixture to start normally takes it out of service mode.

Control options

You can control the MAC Allure Profile using DMX and/or Martin P3 video protocol. The fixture auto-senses the type of data that it is receiving and will respond correctly with no need for manual protocol selection.

The following options are available:

- DMX control over standard DMX cable connected to the fixture's 5-pin XLR connectors.
- DMX control using Art-Net over Ethernet cable connected to the fixture's etherCON connectors.
- DMX control using streaming ACN over Ethernet cable connected to the fixture's etherCON connectors.
- DMX control over DMX cable and P3 video display data over Ethernet cable.
- P3 video display data with embedded DMX commands over Ethernet cable. If you connect DMX / Art-Net / sACN to the P3 system controller, the controller can merge the DMX commands into the P3 video signal and send them to the fixture over Ethernet.

You can decide how the fixture should behave if it receives both a DMX signal at its XLR connectors and a P3 signal at its etherCON connectors. The default setting is for the DMX signal to take priority, but you can set the P3 signal to take priority and you can crossfade between DMX and P3.

Fail-safe connection

The MAC Allure Profile has a fail-safe network connection. If the fixture loses power or if you shut it down, it will continue to relay an Ethernet signal, and the Art-Net / sACN / P3 signal to the other networked fixtures in the daisy chain will not be interrupted.

Data rate

Any Ethernet switch used to relay Art-Net, streaming ACN or P3 data to the MAC Allure Profile must be capable of running at 10/100 Mbps speed, as the fixture does not support Gigabit Ethernet data rates.

DMX

The MAC Allure Profile accepts a DMX-512A data signal.

DMX setup

The DMX address, also known as the start channel, is the first channel used to receive instructions from the controller. For independent control, each fixture must be assigned its own control channels. If you give two MAC Allure Profile fixtures the same address, they will behave identically. Address sharing can be useful for diagnostic purposes and symmetrical control, particularly when combined with the inverse pan and tilt options.

DMX addressing is limited to make it impossible to set the DMX address so high that you are left without enough control channels for the fixture.

To set the fixture's DMX address:

1. Press Enter to open the main menu.
2. Press Enter to enter the **DMX ADDRESS** menu, then scroll to the desired address and press Enter to save.
3. Press Menu to exit.

DMX modes

The **CONTROL MODE** menu lets you set the MAC Allure Profile to one of the two DMX operating modes, Basic and Extended:

- Basic mode offers 8-bit control of strobe, CTC effects, virtual color wheel, prism, iris, FX and other selection functions plus 16-bit control of RGB, dimmer, gobo wheel indexing and rotation, zoom, focus, pan and tilt.
- Extended mode includes all the functionality of Basic mode but adds individual 16-bit RGB control of each of the fixture's seven pixel segments. Use Extended mode if you want to patch virtual dimmers to individual pixels.

To set the fixture's DMX mode:

1. Press Enter to enter the main menu.
2. Scroll to **CONTROL MODE**, then press Enter. Scroll to select either **BASIC** or **EXTENDED**, then press Enter to save.
3. Press Menu to exit.

Note that a P3 controller connected to the MAC Allure Profile will always treat the fixture as seven individual pixels, regardless of whether the fixture is in Basic or Extended DMX mode.

Art-Net and streaming ACN setup

The MAC Allure Profile automatically assigns itself an IP address when connected to Art-Net and sACN, as provided for in the Art-Net and sACN standards. Manually assigning IP addresses is not necessary.

In the **DMX SETUP** menu in the control panel, you can allocate the fixture to a DMX universe for multiple DMX control via Art-Net or sACN.

Using the **ETHERNET SETUP** menu in the control panel, you can display the fixture's current IP address and subnet mask or assign new ones by entering them manually. You can also display the fixture's MAC address.

RDM

The MAC Allure Profile can communicate over standard DMX cable and over Art-Net and sACN Ethernet links using RDM (Remote Device Management) in accordance with ESTA's *American National Standard E1.20-2006*.

RDM is a bi-directional communications protocol for use in DMX512 control systems, it is the open standard for DMX512 device configuration and status monitoring.

The RDM protocol allows data packets to be inserted into a DMX512 data stream without affecting existing non-RDM equipment. It allows a console or dedicated RDM controller to send commands to and receive messages from specific fixtures.

RDM ID

Each MAC Allure Profile has a factory-set RDM UID (unique identification number) that makes it addressable and identifiable in RDM systems. The number can be found in the control panel **INFORMATION** menu under **RDM UID**.

RDM communication

The MAC Allure Profile supports the standard RDM PIDs (Parameter IDs) required by ESTA plus a range of manufacturer-specific PIDs. Sending **SUPPORTED_PARAMETERS** and **PARAMETER_DESCRIPTION** commands from an RDM controller will call up a list of the PIDs supported by the fixture.

Note that a firmware update can sometimes expand a fixture's RDM functionality. If this happens, the firmware release notes will give details.

P3 video

The MAC Allure Profile accepts video data using Martin's proprietary P3 video protocol that has been a well-established standard in the industry for over 10 years. It lets you send a video signal from a media server or other video source to P3-compliant video display devices and LED lighting fixtures over Ethernet cable using Martin's reliable P3 data protocol.

The intuitive graphic user interface in Martin P3 controllers lets you visualize and set up a custom installation that can contain a huge number of display devices in any kind of physical arrangement within a few minutes. Device identification is automatic. You can arrange devices on the monitor using drag-and-drop. System latency is often zero and typically < 1 ms. If you use P3 you do not need to worry about IP addresses, as P3 does not use IP addresses or communication.

The MAC Allure Profile's seven segments will always be treated as seven individual pixels in by a P3 video system controller, regardless of whether the fixture is set to Basic or Extended DMX mode.

Fixture setup

The onboard control panel (see “Effects” on page 5) and the Control / settings DMX channel let you configure the fixture via a range of fixture settings.

Fixture ID

The MAC Allure Profile lets you set a four-digit ID number to ease identification of the fixtures in an installation. When a fixture is powered on for the first time, it displays its DMX address by default. As soon as you set an ID number other than **0** in **FIXTURE ID**, the MAC Allure Profile will display this ID number by default, and indicate **FIXTURE ID** in the display.

Personality

The MAC Allure Profile provides several options that let you optimize the fixture for different applications in the **PERSONALITY** menu:

- The **PAN/TILT** menu lets you swap and/or invert pan and tilt. It also lets you set minimum and maximum limits for pan and tilt.
- The **SPEED** menu lets you set **PAN/TILT** to **NORMAL**, **FAST** (optimized for speed) or **SLOW** (optimized for smooth movement – useful for slow movements in long-throw applications). Likewise, you can select an overall speed for all the effects by setting **EFFECT** speed to **NORMAL**, **FAST** or **SLOW**. You can also set effect speed to **FOLLOW P/T**, in which effects will always use whatever speed is set for pan and tilt.
- **DIMMER CURVE** provides four dimming options (see Figure 5):

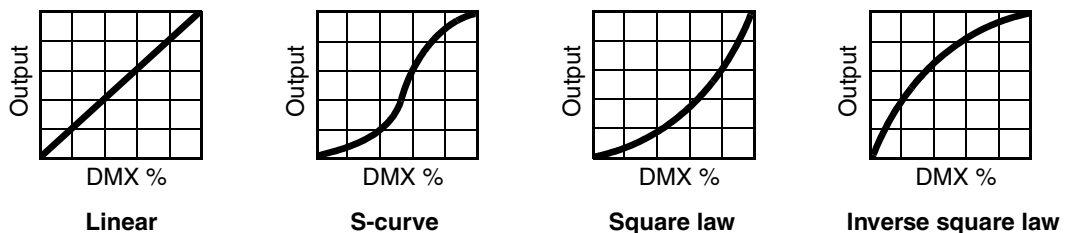

Figure 5: Dimming curve options

- **LINEAR** – (optically linear) the increase in light intensity appears to be linear as DMX value is increased.
- **S-CURVE** – light intensity control is finer at low levels and high levels and coarser at medium levels. This curve emulates the RMS voltage dimming characteristics of an incandescent lamp such as the tungsten halogen lamp of the Martin™ MAC TW1™.
- **SQUARE LAW** – light intensity control is finer at low levels and coarser at high levels.
- **INV SQUARE LAW** – light intensity control is coarser at low levels and finer at high levels.
- **TUNGSTEN EMULATOR** lets you choose to have the look and feel of a tungsten lamp. Color temperature and dimming characteristics emulate tungsten lamp behavior, with a shift towards warmer white when you dim the fixture down.
- **COLOR MODE** offers two options that affect color saturation and evenness between fixtures:
 - **Extended Color** mode optimizes LED deployment for color saturation and gets the deepest color saturation possible from the LEDs. The white color point is calibrated and even across different fixtures, but as the fixture approaches full color saturation there can be very small differences in color rendition between different fixtures.
 - **Calibrated Color** mode optimizes LED deployment for even color rendition between fixtures. All fixtures display identical color from white point to full color saturation, and maximum color saturation levels are limited slightly to ensure this.

- **VIDEO TRACKING** optimizes performance if the MAC Allure Profile is used with a video source. In normal use, the fixture processes the signal it receives, tracking (or smoothing out) changes in values in order to ensure smooth fading between colors and/or intensities. This signal processing takes fractions of a second and is normally invisible, but if the fixture is used to display video the processing can interfere with video response times. If you enable video tracking, the fixture does not 'smooth out' input but instead snaps instantly when a value changes.
For best results, we recommend that you enable video tracking during P3 video display and disable it (the default setting) during DMX control.
- **DMX RESET** defines whether the fixture or individual effects can be reset by sending a DMX command on the fixture settings channel. Setting it to OFF can help you avoid accidentally sending a Reset command during a show, for example.
- **EFFECT SHORTCUT** determines whether the effects take the shortest path between two positions (shortcuts enabled) or not (shortcuts disabled). If shortcuts are enabled, the virtual color wheel effect can go through a virtual open position during changes from one color to another just as a mechanical color wheel would.
- **COOLING MODE** lets you select between two cooling fan options depending on whether your priority is highest light output or quietest cooling fan operation:
 - **REGULATE FANS** optimizes cooling fan operation for light output. It controls fixture temperature by varying cooling fan speed up to the maximum speed available and does not limit light intensity.
 - **REGULATE INTENSITY** optimizes cooling fan operation for quietness. It limits cooling fan speed to a level that causes minimal noise and controls fixture temperature by limiting light intensity when necessary.
- **DISPLAY** offers the following options for the LCD display:
 - **DISPLAY SLEEP** determines whether the display remains on permanently, or goes into sleep mode 2, 5 or 10 minutes after the last time a control panel button is pressed.
 - **DISPLAY INTENSITY** lets you define the brightness of the display backlighting. Select **Auto** for automatic adjustment to match the ambient light level, or manually set the intensity to a level from 0% to 100%.
 - **DISPLAY ROTATION** lets you rotate the display manually through 180° so that it can be read easily no matter how the fixture is oriented. If set to **Auto**, the MAC Allure Profile senses its orientation and rotates the display automatically.
 - **DISPLAY CONTRAST** lets you define the contrast of the backlit graphic display. Select **Auto** for automatic adjustment to match display intensity, or manually set the contrast to a level from 0% to 100%.
- **ERROR MODE** enables or disables error warnings. If set to **NORMAL**, the display is activated and lights up if the fixture needs to report an error. If set to **SILENT**, the fixture does not light the display with error warnings but error messages can still be read when the display is activated manually. In both **NORMAL** and **SILENT** modes, the status LED lights amber to indicate a warning and red to indicate an error.
- **HIBERNATION MODE** sets light output intensity to zero and disables effect deployment and pan/tilt movement. The main purpose of the mode is to protect the fixture from the intake of airborne material such as dust and confetti and to provide an option for situations where noise is critical. The small reduction in power consumption obtained in Hibernation Mode is a by-product.
When you bring the fixture out of hibernation mode, it performs a full reset.

Factory defaults

FACTORY DEFAULT lets you reload the fixture's factory default settings. Effect calibration settings are not affected, so any changes you have made to zoom, pan and tilt offsets will be kept.

Custom settings

The custom configuration function CUSTOM 1 - CUSTOM 3 allows you to save and recall up to three sets of fixture settings. The savable settings comprise:

- all the settings in the PERSONALITY menu,
- the fixture's DMX address, and
- the fixture's DMX control mode: Extended 16-bit or Basic 16-bit mode.

Fixture information readouts

The following fixture information can be called up in the display:

- **POWER ON TIME** provides two counters:
 - The **TOTAL** counter is not user-resettable and displays total hours powered on since manufacture.
 - The **RESETTABLE** counter is user-resettable and displays the number of hours the fixture has been powered on since the counter was last reset.
- **POWER ON CYCLES** also provides two counters:
 - The **TOTAL** counter is not user-resettable and displays the total number of power on/off cycles since manufacture.
 - The **RESETTABLE** counter is user-resettable and displays the number of power on/off cycles since the counter was last reset.
- **SW VERSION** displays the currently installed firmware (fixture software) version.
- **RDM UID** displays the fixture's factory-set unique ID for identification in RDM systems.
- **FAN SPEEDS** provides separate status readouts from the fixture's cooling fans.
- **TEMPERATURES** provides separate PCB temperature readouts. You can choose to see the current readout or the minimum and maximum temperature levels since the fixture was last powered on.

DMX signal monitoring

The MAC Allure Profile provides data on the DMX signal it is receiving in the **DMX LIVE** menu. This information can be useful for troubleshooting control problems.

- **RATE** displays the DMX refresh rate in packets per second. Values lower than 10 or higher than 44 may result in erratic performance, especially when using tracking control.
- **QUALITY** displays the quality of the received DMX data as a percentage of usable packets from the data received. Values much below 100 indicate interference, poor connections, or other problems with the serial data link that are the most common cause of control problems.
- **START CODE** displays the DMX start code. Packets with a start code other than 0 may cause irregular performance.

The remaining options under **DMX LIVE** display the DMX values in a range from 0 - 255 that are being received on each channel. The DMX channels displayed depend on whether the fixture is in Basic or Extended DMX mode.

Test sequences

The **TEST** menu lets you test all the fixture's effects, test LED effects only, test mechanical effects only or test pan and tilt only. If you are going to run a test, be prepared for the head to move without warning and be prepared for the fixture to light up suddenly.

To run a test:

- In the **TEST** menu, scroll to **TEST ALL**, **TEST LEDS**, **TEST EFFECTS** or **TEST PAN/TILT** and press Enter.
- Scroll to the item you want to test and press Enter to start a test sequence for that item.
- Press Menu to stop the test sequence.

Manual control

The **MANUAL CONTROL** menu lets you reset the MAC Allure Profile and operate the fixture without a DMX controller. To execute commands in the **MANUAL CONTROL** menu, select a menu item for the effect that you want to control, then enter a value from 0 to 255 to apply a command. The menu items and values correspond to the commands listed in the DMX protocol on page 21.

Service utilities

The control panel **SERVICE** menu provides utilities for technicians rigging or servicing the fixture:

- **ERROR LIST** displays any error messages that are stored in internal memory.
- **FAN CLEAN** lets you set all cooling fans to run at maximum speed for short periods for cleaning purposes.
- **PT FEEDBACK** lets you disable feedback to the fixture software from the pan, tilt and effects positioning systems. If feedback is set to **ON** and a pan, tilt or effect position error is detected, the shutter closes and the effect resets. This feature can be disabled by setting feedback to **OFF**.
The **OFF** setting is not saved when the fixture is powered off, and the system will be re-enabled the next time the fixture starts. If a pan/tilt position error occurs and the system cannot correct pan/tilt position within 10 seconds, feedback is automatically disabled.
- **ADJUST** lets you set the pan and tilt home positions in the unlikely event that the fixture loses pan and tilt adjustment. Adjustment may also be required by some firmware updates. If so, this will be mentioned in the firmware release notes.
- **CALIBRATION** lets you set new default positions for calibration purposes, set effects to their factory default positions or overwrite the factory default positions with new values. See "Calibration" below.
- **USB** lets you update the firmware (fixture software) using a USB memory device. For a detailed guide to updating the firmware, see "Installing using a USB memory device" later in this chapter.

Calibration

Martin fixtures are adjusted and calibrated at the factory, and further calibration should only be necessary if fixtures have been subjected to abnormal shocks during transport or if normal wear and tear has affected alignment after an extended period of use. You can also use calibration to fine-tune fixtures for a particular location or application.

The **CALIBRATION** menu lets you define offsets in the fixture software to adjust the positions of pan, tilt and effects relative to the DMX values the fixture receives. This allows you to fine-tune fixtures and achieve uniform behavior in different fixtures.

Calibration can be carried out using the fixture's onboard control panel and via DMX (see "Changing calibration offsets using DMX" on page 19).

A recommended procedure is to set pan, tilt and effects to the same DMX values in multiple fixtures and then calibrate each fixture using its onboard control panel while comparing its light output with a reference fixture. The calibration range available for each effect varies. Calibration values are expressed as percentages. After selecting a value, press Enter to set the effect to that value.

Loading and storing default calibration offsets

In the **SERVICE** → **CALIBRATION** menu, **LOAD DEFAULTS** lets you erase the calibration offsets that you have defined and reload the default calibration offsets that are stored in memory.

SERVICE → **CALIBRATION** → **SAVE DEFAULTS** lets you overwrite the factory default calibration offsets that are stored in memory with any new offsets that you have defined. Overwriting is permanent, so once you have saved new default offsets, **LOAD DEFAULTS** will load the new defaults, not the original factory defaults.

Installing firmware

You can check the currently installed firmware (fixture software) version in the **INFORMATION** menu in the MAC Allure Profile's control panel.

Firmware updates are available from the Martin website and can be installed using one of the following methods:

- A USB memory device inserted into the USB port beside the control panel.
- A Windows PC running the Martin Companion software suite with a Martin Companion Cable USB/DMX hardware interface connected to the DMX link.
- A Martin P3 system controller connected to the fixture via the Ethernet cable.

Calibration data is stored in the relevant modules wherever possible so that a module will stay calibrated if it is removed from the fixture or installed in another fixture.

Important! Do not switch the fixture off or disconnect the source of the firmware during an update, or the firmware will be corrupted.

Installing using a USB memory device

The following are required in order to install firmware using a USB memory device:

- The MAC Allure Profile '.BANK' firmware update file, available for download from the Martin website at www.martin.com.
- A USB memory stick or other USB memory device with the update file copied from a PC into the USB stick's root directory.

To install the MAC Allure Profile firmware:

1. Download the '.BANK' firmware file from the MAC Allure Profile area at www.martin.com, read the firmware release notes carefully to check for any instructions or warnings, and copy the firmware file to the root directory of a USB stick.
2. Disconnect the data link from the MAC Allure Profile.
3. Insert the USB stick into the MAC Allure Profile's USB host socket. The fixture should recognize the USB stick and illuminate the display. If the fixture does not recognize the USB stick, navigate to **SERVICE** → **USB** in the control panel.
4. **AVAILABLE FIRMWARE** will appear in the display. You can now scroll through the firmware versions available.
5. To install a firmware version, select it and press Enter. The MAC Allure Profile asks you to confirm installation of the new firmware. Press Enter to confirm and press Menu to exit without confirming.
6. Allow the fixture to install the firmware and reboot. Do not remove the USB stick until the fixture has successfully rebooted.
7. Remove the USB stick. The newly-installed firmware version will now be displayed in the **INFORMATION** menu.
8. Reconnect the data link.
9. If you have installed a new firmware version, check the MAC Allure Profile area of www.martin.com to see whether an updated version of this User Guide is available for the new firmware.

Fixture information and settings are not affected when you upload new firmware to the fixture.

Installing using a PC running Martin Companion

The following are required in order to install firmware using a PC:

- A Windows PC running the latest version of the Martin Companion software suite (available for download free of charge from the Martin website at www.martin.com).
- The MAC Allure Profile firmware file, which the Martin Companion application will download automatically when you run Martin Companion on a PC with an Internet connection.
- The Martin Companion Cable USB-DMX hardware interface, available from your Martin supplier by ordering P/N 91616091.

To install the MAC Allure Profile firmware:

1. Connect your PC to the Internet and launch the Martin Companion application. The application will automatically download the latest Martin fixture firmware from the Martin website.
2. Read the firmware release notes carefully to check for any instructions or warnings.
3. Connect the Martin Companion Cable hardware interface to your PC and to the DMX link. Any fixtures on the DMX link that are powered on will automatically recognize that Martin Companion has been connected.
4. Carry out a firmware upload from within the Martin Companion application (see the application's help files if necessary). Do not disconnect the Martin Companion cable until the upload is complete.

Installing from a P3 controller

To install firmware in the MAC Allure Profile from a Martin P3 controller, you must first download the latest MAC Allure Profile firmware file from the MAC Allure Profile of the Martin website at www.martin.com and then import the firmware into the P3 controller. You can then use the P3 controller to upload the firmware to all the fixtures on the network that are powered on.

When you import new firmware into a P3 controller, it will automatically recognize old firmware in fixtures and suggest a firmware update.

When carrying out firmware updates the P3 controller must be connected to fixtures via Ethernet cable as normal. Updating the firmware is a fairly intuitive process using the commands available in the controller interface. Any fixtures that are powered on will recognize that the P3 controller is offering a firmware update and prepare to receive the firmware.

Adjusting settings via DMX

Certain fixture settings and parameters can be adjusted from the DMX controller on the Fixture control/settings channel.

Commands sent on the fixture control channel override any settings entered in the fixture's onboard control menus.

To help you avoid accidentally applying a setting that may disrupt a light show, for example, most of the commands must be held for a certain time before they are applied. For example, the command that turns off the display illumination must be held for one second to activate it. The command that resets the fixture must be held for five seconds to activate it. The times required to apply DMX commands on the Fixture control/settings channel are listed for each command on page 24 in the DMX protocol.

Resetting

Either the entire fixture or individual effects can be reset to their initial positions. Resetting individual effects can allow on-the-fly recovery if an effect loses its correct position, for example, without having to reset the entire fixture.

Illuminating the display

The fixture's display panel can be brought out of sleep mode with a DMX command. This makes it possible to read the fixture's DMX address while the fixture is installed in the rig.

After being illuminated in this way, the display will return to sleep mode according to the setting entered in the onboard control menus.

Control menu setting overrides

The following fixture settings can be adjusted via DMX, overriding the settings entered in the onboard control menus. See under "Control panel menus" on page 29 for details of these settings.

- Dimming curve
- Pan and tilt speed
- Parameter shortcuts (beam twister shortcuts)
- Video tracking
- Color mode
- Fan speed
- Pan/tilt and zoom calibration offsets

Changing calibration offsets using DMX

The Fixture control/settings DMX channel allows pan, tilt and zoom to be calibrated by changing their factory default offsets IN PERCENT from the DMX controller.

To set an effect offset:

1. Set the effect you want to calibrate to a specific value via DMX (for example, set all the fixtures in a group to DMX value 200 on the zoom channel).
2. Select 'Enable calibration' on the Fixture control/settings channel and hold for 5 seconds to activate.
3. The DMX control channels for pan, tilt and zoom now adjust the calibration offsets for those effects. Adjust each offset until the effect is in the required position (for example, adjust the zoom offset on each fixture in the group until the beam angle on all fixtures is identical – this is the position you will obtain when you send DMX value 200).
4. Send a 'Store ...' command for the effect on the Fixture control/settings channel and hold for 5 seconds to activate. Calibration offsets are now stored in memory and normal DMX control is restored.

Calibration offsets that are stored in memory are not affected by powering the fixture off and on or by updating the fixture software.

You can reset all calibration offsets to their default values by sending a DMX value on the Fixture control/settings channel. You must hold the value for 5 seconds. The fixture will return to factory default calibration values. If you have overwritten the factory default values by applying a CALIBRATION → SAVE DEFAULTS command in the SERVICE menu, the fixture will return to the last default calibration values that were saved).

DMX protocol

MAC Allure Profile firmware version 1.0.0.

Basic DMX Mode

Channel	DMX Value	Function	Fade type	Default value
1	0 - 19	Strobe/shutter effect Shutter closed Shutter open Strobe, slow → fast Shutter open Random strobe, slow → fast	Snap	30
	20 - 49			
	50 - 200			
	201 - 210			
	211 - 255			
2	0 - 65535	Dimmer fade (MSB) Closed → open	Fade	0
3		Dimmer fade, fine (LSB)	Fade	0
4	0 - 10	CTC Disabled Color temperature 2000 K to 10 000 K in 50 K steps 10 000 K	Fade	0
	11 - 171			
	172 - 255			
5	0 - 10	Virtual color wheel Indexing <i>Solid colors</i> Open Moroccan pink (Lee 790) Pink (Lee 157) Special rose pink (Lee 332) Follies pink (Lee 328) Fuchsia pink (Lee 345) Surprise pink (Lee 194) Congo blue (Lee 181) Tokyo blue (Lee 071) Deep blue (Lee 120) Just blue (Lee 079) Medium blue (Lee 132) Double CT blue (Lee 200) Slate blue (Lee 161) Full CT blue (Lee 201) Half CT blue (Lee 202) Steel blue (Lee 117) Lighter blue (Lee 353) Light blue (Lee 118) Medium blue green (Lee 116) Dark green (Lee 124) Primary green (Lee 139) Moss green (Lee 089) Fern green (Lee 122) Jas green (Lee 738) Lime green (Lee 088) Spring yellow (Lee 100) Deep amber (Lee 104) Chrome orange (Lee 179) Orange (Lee 105) Gold amber (Lee 021) Millennium gold (Lee 778) Deep golden amber (Lee 135) Flame red (Lee 164) Red magenta Medium lavender Pure white Continuous rotation CW, fast → slow Stop (wheel stops at current color) CCW slow → fast	Snap	0
	11			
	13			
	15			
	17			
	19			
	21			
	23			
	25			
	27			
	29			
	31			
	33			
	35			
	37			
	39			
	41			
	43			
	45			
	47			
	49			
	51			
	53			
	55			
	57			
	59			
	61			
	63			
	65			
	67			
	69			
	71			
	73			
75				
77				
78				
80				
81 - 102				
103 - 105				
106 - 127				

Table 1: DMX Protocol

Channel	DMX Value	Function	Fade type	Default value	
5 contd.	128	Split colors			
	130	Split color 1			
	132	Split color 2			
	134	Split color 3			
	136	Split color 4			
	138	Split color 5			
	140	Split color 6			
	142	Split color 7			
	144	Split color 8			
	146	Split color 9			
	148	Split color 10			
	150	Split color 11			
	152	Split color 12			
	154	Split color 13			
	156	Split color 14			
	158	Split color 15			
	160	Split color 16			
	162	Split color 17			
	164	Split color 18			
	166	Split color 19			
	168	Split color 20			
	170	Split color 21			
	172	Split color 22			
	174	Split color 23			
	176	Split color 24			
	178	Split color 25			
	180	Split color 26			
	182	Split color 27			
	184	Split color 28			
	186	Split color 29			
	188	Split color 30			
	190	Split color 31			
	192	Split color 32			
	194	Split color 33			
196	Split color 34				
198	Split color 35				
	198	Split color 36			
		Continuous rotation			
	199 - 220	CW fast → slow			
	221 - 223	Stop (wheel stops at current position)			
	224 - 255	CCW slow → fast			
6		Gobo wheel: gobo selection, indexing, shake, rotation			
		<i>Indexed gobo: set indexed angle on channels 7/8</i>			
		0 - 4	Open		
		5 - 9	Gobo 1		
		10 - 14	Gobo 2		
		15 - 19	Gobo 3		
		20 - 24	Gobo 4		
		25 - 29	Gobo 5		
		30 - 34	Gobo 6		
			<i>Continuous gobo rotation: set gobo rotation speed on channels 7/8</i>		
		35 - 39	Gobo 1		
		40 - 44	Gobo 2		
		45 - 49	Gobo 3		
		50 - 54	Gobo 4		
		55 - 59	Gobo 5	Fade	0
		60 - 64	Gobo 6		
			<i>Gobo shake centered on indexed position. Set indexed position on channels 7/8</i>		
			Shake angle increments in following steps: 10°, 15°, 30°, 45°, 60°, 90°, 135°, 180°, 270° and 360°		
		65 - 88	Gobo 1 shake, 360° slow → 10° fast		
		89 - 112	Gobo 2 shake, 360° slow → 10° fast		
		113 - 136	Gobo 3 shake, 360° slow → 10° fast		
		137 - 160	Gobo 4 shake, 360° slow → 10° fast		
		161 - 184	Gobo 5 shake, 360° slow → 10° fast		
	185 - 208	Gobo 6 shake, 360° slow → 10° fast			
		<i>Continuous gobo wheel rotation with continuous gobo rotation: set gobo rotation speed on channels 10/11</i>			
	210 - 232	CW gobo wheel rotation, fast → slow			
	233 - 255	CCW gobo wheel rotation, slow* → fast			

Table 1: DMX Protocol

Channel	DMX Value	Function	Fade type	Default value
7		Gobo wheel: indexed angle, rotation direction and speed		
	0 - 65535	<i>Indexed position (if gobo wheel set to indexed gobo on channel 6):</i> Indexed position (0° at 32768)		
8	0 - 600 601 - 32130 32131 - 32895 32896 - 64515 64516 - 65535	<i>Rotation (if wheel set to continuous gobo rotation on channel 6):</i> No rotation, gobo indexed at 0° CW rotation fast → slow No rotation, gobo stops at current position CCW rotation slow → fast No rotation, gobo indexed at 90°	Fade	32768
9	0 - 10 11 - 138 139 - 255	Prism Open Prism indexing Prism rotation	Snap	0
10	0 - 255 0 - 2 3 - 126 127 - 129 130 - 253 254 - 255	Prism: indexed angle, rotation speed and direction <i>If indexing is selected on channel 9:</i> Indexed angle min. → max. (0° at 128) <i>If rotation is selected on channel 9:</i> Stop, indexed at 0° CW rotation, fast → slow Stop, wheel stops at its current position CCW rotation, fast → slow Stop, indexed at 45°	Snap	127
11	0 - 200 201 - 225 226 - 230 231 - 255	Iris with pulse Open → Closed Pulse fast → slow Stop, iris stops at current position Reverse pulse slow → fast	Snap	0
12		Zoom, 16-bit (MSB and LSB)		
13	0 - 65535	Flood → spot	Fade	32768
14		Focus, 16-bit (MSB and LSB)		
15	0 - 65535	Infinity → near	Fade	32768
16		Pan, 16-bit (MSB and LSB)		
17	0 - 65535	Left → right (32768 = neutral)	Fade	32768
18		Tilt, 16-bit (MSB and LSB)		
19	0 - 65535	Up → down (32768 = neutral)	Fade	32768

Table 1: DMX Protocol

Channel	DMX Value	Function	Fade type	Default value	
20		Fixture control/settings <i>(hold for number of seconds indicated to activate)</i>			
	0 - 9	<i>No function (disables calibration) – 5 sec.</i>			
	10 - 14	Reset entire fixture – 5 sec.			
	15 - 16	<i>No function</i>			
	17	Reset beam only – 5 sec.			
	18	Reset pan and tilt only – 5 sec.			
	19 - 22	<i>No function</i>			
	23	Linear dimming curve – 1 sec. (menu override, setting unaffected by power off/on)			
	24	Square law dimming curve – 1 sec. (menu override, default setting, setting unaffected by power off/on)			
	25	Inverse square law dimming curve – 1 sec. (menu override, setting unaffected by power off/on)			
	26	S-curve dimming curve – 1 sec. (menu override, setting unaffected by power off/on)			
	27	<i>No function</i>			
	28	Fast pan and tilt speed – 1 sec. (default setting, menu override - setting returns to MENU setting after power on/off)			
	29	Smooth pan and tilt speed – 1 sec. (menu override - setting returns to MENU setting after power on/off)			
	30	Parameter shortcuts = ON (default) – 1 sec.			
	31	Parameter shortcuts = OFF – 1 sec.			
	32	Focus tracking = OFF – 1 sec.			
	33	Enable focus tracking, close range – 1 sec.			
	34	Enable focus tracking, medium range (default) – 1 sec.			
	35	Enable focus tracking, long range – 1 sec.			
	36	Video tracking = ON – 1 sec.			
	37	Video tracking = OFF – 1 sec.			
	38	Extended color mode (default) – 1 sec.			
	39	Calibrated color mode – 1 sec.			
	40 - 51	<i>No function</i>			
	52	Control panel display = ON – 1 sec.		Snap	0
	53	Control panel display = OFF – 1 sec.			
	54	Regulated fan speed, fixed light output intensity (default) – 1 sec.			
	55	Full fan speed, regulated light output intensity – 1 sec.			
	56	Medium fan speed, regulated light output intensity – 1 sec.			
	57	Low fan speed, regulated light output intensity – 1 sec.			
	58	Ultra-low fan speed, regulated light output intensity – 1 sec.			
	59 - 60	<i>No function</i>			
	61	Hibernation mode = ON – 5 sec.			
	62	Hibernation mode = OFF – 5 sec.			
	63 - 64	<i>No function</i>			
	65	Pan and tilt limits = ON – 5 sec.			
	66	Pan and tilt limits = OFF – 5 sec.			
	67	Store lower pan limit – 5 sec.			
	68	Store upper pan limit – 5 sec.			
	69	Store lower pan limit – 5 sec.			
	70	Store upper pan limit – 5 sec.			
	71	Reset pan and tilt limits – 5 sec.			
	72	Tungsten emulation = ON – 1 sec.			
	73	Tungsten emulation = OFF – 1 sec.			
	74 - 99	<i>No function</i>			
	100	Enable calibration – 5 sec.			
101	Store pan and tilt calibration – 5 sec.				
102	Store dimmer calibration – 5 sec.				
103 - 107	<i>No function</i>				
108	Store rotating gobo 1 current slot index calibration – 5 sec.				
109 - 111	<i>No function</i>				
112	Store iris calibration – 5 sec.				
113	Store focus calibration – 5 sec.				
114	Store zoom calibration – 5 sec.				
115 - 198	<i>No function</i>				
199	Reset all calibration values to factory default – 5 sec.				
200 - 255	<i>No function</i>				

Table 1: DMX Protocol

Channel	DMX Value	Function	Fade type	Default value
21	0 - 26	P3 Mode <i>DMX Mode</i> Output fully controlled by DMX (P3 pixel data ignored)	Snap	0
	27	<i>Mixed Mode</i> Output fully controlled by DMX (P3 pixel data ignored)		
	27 - 227	Progressive crossfade from DMX to P3 control		
	228	Output fully controlled by P3 (DMX data ignored)		
22	229 - 255	<i>Video Mode</i> P3 pixel control with DMX superimposed (DMX channels 'color' the P3 pixel data)	Snap	0
	0 - 255	FX1 selection (see Table 3 on page 28) Effect selection (adjust speed and direction on DMX channel 23)		
23	0 - 126	FX1 speed Effect reversed fast → slow	Fade	128
	127 - 129	Effect stops		
	130 - 255	Effect forward slow → fast		
24	0 - 255	FX2 selection (see Table 3 on page 28) Effect selection (adjust speed and direction on DMX channel 25)	Snap	0
	0 - 126	FX2 speed Effect reversed fast → slow	Fade	128
127 - 129	Effect stops			
130 - 255	Effect forward slow → fast			
26	0	FX synchronization No sync	Snap	0
	1	Offset shift 10°		
	2	Offset shift 20°		
	3	Offset shift 30°		
	4	Offset shift 40°		
	5	Offset shift 50°		
	6	Offset shift 60°		
	7	Offset shift 70°		
	8	Offset shift 80°		
	9	Offset shift 90°		
	10	Offset shift 100°		
	11	Offset shift 110°		
	12	Offset shift 120°		
	13	Offset shift 130°		
	14	Offset shift 140°		
	15	Offset shift 150°		
	16	Offset shift 160°		
	17	Offset shift 170°		
	18	Offset shift 180°		
	19	Offset shift 190°		
	20	Offset shift 200°		
	21	Offset shift 210°		
	22	Offset shift 220°		
	23	Offset shift 230°		
	24	Offset shift 240°		
	25	Offset shift 250°		
	26	Offset shift 260°		
	27	Offset shift 270°		
	28	Offset shift 280°		
	29	Offset shift 290°		
	30	Offset shift 300°		
	31	Offset shift 310°		
	32	Offset shift 320°		
	33	Offset shift 330°		
	34	Offset shift 340°		
	35	Offset shift 350°		
	36	Synchronized: all fixtures start FX cycles at same time		
37 - 100	<i>No function</i>			
101 - 120	Random start (Channel 23 controls overall speed)			
121 - 140	Random duration			
141 - 255	<i>No function</i>			

Table 1: DMX Protocol

Channel	DMX Value	Function	Fade type	Default value
27	0 - 65535	Red, 16-bit (MSB and LSB) 0 → 100%	Fade	32768
28				
29	0 - 65535	Blue, 16-bit (MSB and LSB) 0 → 100%	Fade	32768
30				
31	0 - 65535	Green, 16-bit (MSB and LSB) 0 → 100%	Fade	32768
32				

Table 1: DMX Protocol

Extended DMX Mode

DMX channels 1 - 26 in Extended DMX Mode are identical with Basic DMX Mode. DMX channels 27 - 68 are only available in Extended Mode and add individual RGB control of the fixture's seven pixels.

Channel	DMX Value	Function	Fade type	Default value
27	0 - 65535	Pixel 1 Red, 16-bit (MSB and LSB)	Fade	32768
28		0 → 100%		
29	0 - 65535	Pixel 1 Green, 16-bit (MSB and LSB)	Fade	32768
30		0 → 100%		
31	0 - 65535	Pixel 1 Blue, 16-bit (MSB and LSB)	Fade	32768
32		0 → 100%		
33	0 - 65535	Pixel 2 Red, 16-bit (MSB and LSB)	Fade	32768
34		0 → 100%		
35	0 - 65535	Pixel 2 Green, 16-bit (MSB and LSB)	Fade	32768
36		0 → 100%		
37	0 - 65535	Pixel 2 Blue, 16-bit (MSB and LSB)	Fade	32768
38		0 → 100%		
39	0 - 65535	Pixel 3 Red, 16-bit (MSB and LSB)	Fade	32768
40		0 → 100%		
41	0 - 65535	Pixel 3 Green, 16-bit (MSB and LSB)	Fade	32768
42		0 → 100%		
43	0 - 65535	Pixel 3 Blue, 16-bit (MSB and LSB)	Fade	32768
44		0 → 100%		
45	0 - 65535	Pixel 4 Red, 16-bit (MSB and LSB)	Fade	32768
46		0 → 100%		
47	0 - 65535	Pixel 4 Green, 16-bit (MSB and LSB)	Fade	32768
48		0 → 100%		
49	0 - 65535	Pixel 4 Blue, 16-bit (MSB and LSB)	Fade	32768
50		0 → 100%		
51	0 - 65535	Pixel 5 Red, 16-bit (MSB and LSB)	Fade	32768
52		0 → 100%		
53	0 - 65535	Pixel 5 Green, 16-bit (MSB and LSB)	Fade	32768
54		0 → 100%		
55	0 - 65535	Pixel 5 Blue, 16-bit (MSB and LSB)	Fade	32768
56		0 → 100%		
57	0 - 65535	Pixel 6 Red, 16-bit (MSB and LSB)	Fade	32768
58		0 → 100%		
59	0 - 65535	Pixel 6 Green, 16-bit (MSB and LSB)	Fade	32768
60		0 → 100%		
61	0 - 65535	Pixel 6 Blue, 16-bit (MSB and LSB)	Fade	32768
62		0 → 100%		
63	0 - 65535	Pixel 7 Red, 16-bit (MSB and LSB)	Fade	32768
64		0 → 100%		
65	0 - 65535	Pixel 7 Green, 16-bit (MSB and LSB)	Fade	32768
66		0 → 100%		
67	0 - 65535	Pixel 7 Blue, 16-bit (MSB and LSB)	Fade	32768
68		0 → 100%		

Table 2: DMX Protocol

FX: pre-programmed effects

The table below lists the pre-programmed dynamic FX (effect macros) that are available in Basic and Extended DMX modes.

Select FX on channels 22 and 24 by sending the values listed in the table. Adjust effect speed on channels 23 and 25, and adjust synchronization of effects across different fixtures on channel 26.

Applicable when running MAC Allure Profile firmware version 1.0.0.

DMX value	Effect	DMX value	Effect
0 - 92	No FX	110	Pixel Red White Blue Snaps
93	Pixel Rainbow Wave	111	Single LED Chase
94	Pixel Rainbow Step	112	Double LED Chase
95	Pixel Rainbow Pulse	113	Triple LED Chase
96	Pixel RGB Wave	114	Split Color Flip
97	Pixel RGB Step	115	Split Color Rotation
98	Pixel RGB Pulse	116	Split color Index 45 Deg
99	Pixel CMY Wave	117	Split color Index 90 Deg
100	Pixel CMY Step	118	Atomic Chase
101	Pixel CMY Pulse	119	Triangle Chase
102	Pixel Mix to White Wave	120	Triangle Rotation
103	Pixel Mix to White Step	121	Bar Rotation
104	Pixel Mix to White Pulse	122	Center Outer Chase
105	Pixel Random Mix Wave	123	Center Outer Chase Duo
106	Pixel Random Mix Step	124	Horizontal Swoosh
107	Pixel Random Mix Pulse	125	Vertical Swoosh
108	Pixel Random Subtle Wave	126 - 255	No FX
109	Pixel Red White Blue Fade		

Table 3: FX in the MAC Allure Profile

Control panel menus

MAC Allure Profile firmware version 1.0.0.

Menu level 1	Menu level 2	Menu level 3	Menu level 4	Notes (Default settings in bold print)	
DMX SETUP	DMX ADDRESS	1 – XXX		DMX address (default address = 1). The DMX address range is limited so that the fixture will always have enough DMX channels within the 512 available.	
	DMX CONTROL MODE	BASIC		Basic DMX mode	
		EXTENDED		Extended DMX mode	
	DMX UNIVERSE	1 - 64000		Set DMX universe	
ETHERNET SETUP	IP ADDRESS	XXX.XXX.XXX.XXX		Display fixture's static IP address	
		PART 1 MSB		Set far left block (most significant byte) of IP address	
		PART 2		Set middle left block of IP address	
		PART 3		Set middle right block of IP address	
		PART 4 LSB		Set far right block (most significant byte) of IP address	
	SUBNET MASK	XXX.XXX.XXX.XXX		Display fixture's subnet mask	
		EDIT SUBNET MASK	XXX.XXX.XXX.XXX	Display fixture's subnet mask	
			XXX.XXX.XXX.XXX	Set subnet mask with 1 bit increments from the left	
	MAC ADDRESS	XX:XX:XX:XX:XX:XX		Display fixture's MAC address	
RESET IP SETUP	RESET	ARE YOU SURE? YES/NO	Reset static IP address and subnet mask to default values		
FIXTURE ID	0 – 9999	User-settable fixture ID number		0	
PERSONALITY	PAN/TILT	PAN INVERT	ON/OFF	Inverse DMX pan control: right → left	
		TILT INVERT	ON/OFF	Inverse DMX tilt control: down → up	
		LIMIT PAN/TILT	LIMIT ENABLE	ON/OFF	Enable limits for pan and tilt
			PAN MIN →	-32767 degrees	Set minimum pan angle
			PAN MAX →	32768 degrees	Set maximum pan angle
			TILT MIN →	-32767 degrees	Set minimum tilt angle
			TILT MAX →	32768 degrees	Set maximum tilt angle
	SPEED	PAN/TILT	FAST	Optimize pan/tilt movement for speed	
			SMOOTH	Optimize pan/tilt movement for smoothness	
		EFFECT	FOLLOW P/T	Effects speed follows the speed setting applied to pan and tilt via DMX or in control menu	
			FAST	Optimize effects movement for speed	
			SLOW	Optimize effects movement for smoothness	
	DIMMER CURVE	LINEAR		Optically linear dimming curve	
		SQUARE LAW		Square law dimming curve	
		INV SQ LAW		Inverse square law dimming curve	
		S-CURVE		S-curve (fixture emulates incandescent lamp voltage linear RMS dimming curve)	

Table 4: Control menus

Menu level 1	Menu level 2	Menu level 3	Menu level 4	Notes (Default settings in bold print)	
PERSONALITY (continued)	TUNGSTEN EMULATOR	ON		Color temperature and dimming characteristics emulate tungsten lamp behavior	
		OFF			
	FOCUS TRACKING	FAR		Focus adjusts to match zoom: optimized for long range projection	
		MEDIUM		Focus adjusts to match zoom: optimized for mid-range projection	
		NEAR		Focus adjusts to match zoom: optimized for close range projection	
		DISABLED		Focus tracking function disabled	
	COLOR MODE	EXTENDED COLOR		Color mixing optimized for saturation	
		CALIBRATED		Color mixing optimized for even color rendition across fixtures	
	VIDEO TRACKING	ENABLED		Color fading optimized for speed of color changes	
		DISABLED		Color fading optimized for smoothness	
	DMX RESET	ON		Fixture can be reset via DMX	
		OFF		Fixture cannot be reset via DMX (note that this menu item can be overridden: see DMX protocol)	
	EFFECT SHORTCUT	ON		Effects take shortest route during changes, crossing open positions if necessary	
		OFF		Effects avoid open positions during effects changes	
	COOLING MODE	CONSTANT FAN FULL		Fans optimized for maximum light intensity, fans run at full speed, light intensity reduced if necessary to keep fixture within temperature limits	
		CONSTANT FAN MEDIUM		Fans run at medium speed, light intensity reduced if necessary to keep fixture within temperature limits	
		CONSTANT FAN LOW		Fans run at low speed, light intensity reduced if necessary to keep fixture within temperature limits	
		CONSTANT FAN ULOW		Fans optimized for lowest noise, fans run at ultra-low speed, light intensity reduced if necessary to keep fixture within temperature limits	
		REGULATE FANS		Compromise between light intensity and quietness, fan speed temperature-regulated, light intensity only reduced if fans reach full speed and further action necessary to keep fixture within temperature limits	
	DISPLAY	DISPLAY SLEEP	10 MINUTES		Display goes into sleep mode 10 minutes after last key press
			5 MINUTES		Display goes into sleep mode five minutes after last key press
			2 MINUTES		Display goes into sleep mode two minutes after last key press
			ON		Display permanently on
		DISPLAY INTENSITY	10 ... 100 %		Set display intensity in % (default = 100)
		DISPLAY ROTATION	NORMAL / ROTATE 180		Display orientation normal or rotated 180°
		DISPLAY CONTRAST	1 ...100		Adjust contrast of display (default = 41)

Table 4: Control menus

Menu level 1	Menu level 2	Menu level 3	Menu level 4	Notes (Default settings in bold print)
PERSONALITY (continued)	ERROR MODE	NORMAL		Enable error messages and warnings in display
		SILENT		Disable error messages and warnings in display (the status LED will still light to indicate fixture status if an error has been detected or the fixture has a warning)
	HIBERNATION MODE	ON		Enable Hibernation Mode (light output set to zero, all effect movement disabled)
		OFF		Disable Hibernation Mode
DEFAULT SETTINGS	FACTORY DEFAULT	LOAD	ARE YOU SURE? YES/NO	Return all settings (except calibrations) to factory defaults
	CUSTOM 1	LOAD	ARE YOU SURE? YES/NO	Load Custom Settings 1
		SAVE	ARE YOU SURE? YES/NO	Save fixture's current settings as Custom Settings 1
	CUSTOM 2	LOAD	ARE YOU SURE? YES/NO	Load Custom Settings 2
		SAVE	ARE YOU SURE? YES/NO	Save fixture's current settings as Custom Settings 2
	CUSTOM 3	LOAD	ARE YOU SURE? YES/NO	Load Custom Settings 3
		SAVE	ARE YOU SURE? YES/NO	Save fixture's current settings as Custom Settings 3
	INFORMATION	POWER ON TIME	TOTAL	0 ... XXX HR
RESETTABLE			CLEAR COUNTER? YES/NO	Display hours fixture has been powered on since last counter reset (user-resettable)
POWER ON CYCLES		TOTAL	0 ... XXX HR	Display number of times fixture has been powered on since manufacture (not user-resettable)
		RESETTABLE	CLEAR COUNTER? YES/NO	Display number of times fixture has been powered on since last counter reset (user-resettable)
FW VERSION*		XX.XX.XX		Displays currently active firmware version
RDM UID*		4D50.XXXXXXXXXX		Displays fixture's unique RDM ID
FAN SPEEDS*		HEAD FAN 1 ... 6, BASE FAN 1 - 2	0 - XXX RPM	Scroll to display current speed of each cooling fan (head and base)
TEMPERATURES*		UI ... CURRENT DRIVER	CURRENT / MIN / MAX X C	Scroll through PCB temperature sensors, then display current, minimum* and maximum* temperature in °C of all PCBs *Since fixture was last powered on
DMX LIVE*	RATE	0 - 44 HZ		DMX transmission speed in packets per second
	QUALITY	0 - 100%		Percent of packets received
	START CODE	0 - 255		Value of the DMX start code
	STROBE ... FX SYNC	XXX		Scroll to see values received on each DMX channel
TEST**	TEST ALL	DIMMER ... TILT		Run test sequence of all functions To test a specific function, use Up/Down buttons to scroll through functions. Press Enter to pause and press again to restart test sequence. Press Menu button to exit test
	TEST LEDS	DIMMER ... V COLOR WHEEL		Run test sequence of LEDs only. To test a specific LED group, use Up/Down buttons to scroll through groups. Press Enter to pause and press again to restart test sequence. Press Menu button to exit test

Table 4: Control menus

Menu level 1	Menu level 2	Menu level 3	Menu level 4	Notes (Default settings in bold print)	
TEST (continued)**	TEST EFFECTS	GOBO WHEEL ... FOCUS		Run test sequence of effects. To test a specific effect, use Up/Down buttons to scroll through groups. Press Enter to pause and press again to restart test sequence. Press Menu button to exit test	
	TEST PAN/TILT	PAN		Run test sequence of pan functions. Press Menu button to exit test	
		TILT		Run test sequence of tilt functions. Press Menu button to exit test	
MANUAL CONTROL**	RESET			Reset fixture	
	STROBE ... FX SYNC			Scroll through effects, then manually control an effect	
SERVICE	ERROR LIST	Empty or up to 20 errors		Display any errors in memory	
	FAN CLEAN	ON/OFF		Start/stop fan cleaning	
	PT FEEDBACK	ON		Enable pan/tilt position feedback systems	
		OFF		Disable pan/tilt position feedback	
	ADJUST	PAN/TILT AT END STOP	STEP 1	To adjust, move head to P/T adjustment position, then press Enter	
			STEP 2	To adjust, move head to P/T adjustment position again, then press Enter	
	CALIBRATION	DIMMER	-30.00 ... 0.00%		Set max. dimmer intensity level
		RED	-30.00 ... 0.00%		Set max. red intensity level
		GREEN	-30.00 ... 0.00%		Set max. green intensity level
		BLUE	-30.00 ... 0.00%		Set max. blue intensity level
		GOBO W1 SEL	-1.00 ... 1.00%		Calibrate gobo selection
		GOBO W1 I/R	-25.00 ... 25.00%		Calibrate gobo indexing
		PRISM I/R	-25.00 ... 25.00%		Calibrate prism indexing
		IRIS	-5.00 ... 5.00%		Set iris home position
		ZOOM	-5.00 ... 5.00%		Set zoom home position
		FOCUS	-5.00 ... 5.00%		Set focus home position
		PAN	-2.00 ... 2.00%		Set pan home position
		TILT	-2.00 ... 2.00%		Set tilt home position
		LOAD DEFAULTS	LOAD		
	SAVE DEFAULTS	SAVE			Replace factory default calibration settings with current calibration settings
	USB	NO DEVICE		No USB device present or no firmware on USB device	
		UPDATING FILES		Fixture updating internal memory from USB device	
		AVAILABLE FIRMWARE	XX.XX.XX ... XX.XX.XX	Select firmware from versions stored in internal memory. Scroll to select version, then press Enter and confirm your choice to update	

Table 4: Control menus

**Menus marked ** are available only when the fixture is connected to mains power. All other menus are available in mains- and battery-powered operation.

Service and display messages

The MAC Allure Profile gives service and maintenance information by displaying a large 3- or 4-character short code and a smaller full-text message in the fixture's display. The short code is visible at a distance, allowing easier reading with the fixture still in the rig, for example, while the full-text message gives more detailed information.

Warning messages

Warning messages indicate that either:

- problems might appear in the future if no action is taken, or
- the user needs to pay special attention to a function or procedure when working with the fixture.

The MAC Allure Profile communicates warnings as follows:

- Warning codes are shown continuously in the display and disappear when the user reacts to the warning.
- If more than one warning is detected, all warnings are displayed in sequence.
- If the display is inactive, the fixture's status LED (see Figure 4 on page 9) flashes orange to indicate that there is a warning. Activating the display will show the warning.

The possible warning messages are listed in Table 5 below:

Short code	Long message and explanation
BANK	BANK NO ACCESS Error unpacking firmware bank during/after software upload. Fixture will continue to operate on existing firmware. Warning message is cleared by a successful software upload or at the next power off/on cycle.
DCTW	DC TEMP HIGH DC PCB sensor detects abnormally high operating temperature.*
LDTW	LED DRV TMP HIGH LED driver temperature sensor detects abnormally high operating temperature.*
PFTW	PFC TEMP HIGH PFC unit temperature sensor detects abnormally high operating temperature.*
PTTW	PT TEMP HIGH Pan/tilt PCB sensor detects abnormally high operating temperature.*
SERV	SERVICE MODE Fixture in service mode.
SL W	SAFETY LOOP A safety loop error occurred but is no longer active. Warning message is cleared at the next power off/on cycle.
UITW	UI TEMP HIGH User interface (LCD display and control panel) PCB sensor detects abnormally high operating temperature.*
ZFTW	ZF TEMP HIGH Zoom PCB sensor detects abnormally high operating temperature.*

Table 5: Warning messages

**High temperature warnings are canceled as soon as temperature returns to normal. If temperature reaches cutoff level, the warning is replaced by a cutoff error message.*

Error messages

Error messages indicate that a problem is present. The MAC Allure Profile communicates errors as follows:

- Error messages flash in the display.
- If more than one error is detected, the fixture flashes all errors three times each.
- Errors are shown in the display regardless of display status: they override an inactive display and any other information that the display might be showing.
- If an error is present, the status LED flashes red.

The possible error messages are listed in Table 6 below:

Short code	Long message and explanation
CELD	COM ERR LED DRV LED driver communication error.
COLD	FIXTURE COLD Fixture too cold. Physical movement of effects is disabled until fixture has warmed up.
FAN	BASE FAN 1 ERR
FAN	BASE FAN 2 ERR
FAN	BASE FAN 3 ERR
FAN	HEAD FAN 1 ERR
FAN	HEAD FAN 1 ERR
FAN	HEAD FAN 1 ERR
FAN	HEAD FAN 1 ERR
FBEP	PAN FBACK ERR Pan position magnetic indexing system timeout. Fixture is unable to correct pan position (but pan movement will often still be possible).
FBET	TILT FBACK ERR Tilt position magnetic indexing system timeout. Fixture is unable to correct tilt position (but tilt movement will often still be possible).
FBEZ	ZOOM FBACK ERR Zoom position indexing system timeout. Fixture is unable to correct zoom position.
LDTC	LED TEMP SEN ERR LED board temperature sensor error.
LDTE	LED TEMP SEN ERR LED board temperature sensor error.
MMER	MISSING MODULE ERR Impossible to communicate with a module that should be present. Module missing or not correctly connected.
PAER	PAN ERROR Pan position electrical indexing system timeout.
PFTC	PFC TEMP CUT OFF Power factor correction system temperature cutoff.
PFTE	PFC TEMP SEN ERR Power factor correction system temperature sensor error.
PSER	PAN SENSOR ERROR Fixture unable to retrieve reliable data from pan position sensor.
PTCM	P/T SENSOR ADJUST Pan/tilt sensors are incorrectly adjusted.
SLER	SAFETY LOOP Safety loop circuit activated. A temperature circuit breaker has shut down LEDs. Circuit breaker resets automatically after temperature has returned to normal operating range.
TIER	TILT ERROR Tilt position electrical indexing circuit timeout.
TSER	TILT SENSOR ERR Fixture unable to retrieve reliable data from tilt position sensor.
UELD	UPL ERR LED DRV Could not upload new LED driver firmware during a firmware upload. Error cleared when new firmware is uploaded successfully or power is cycled off and on.

Table 6: Error messages

Short code	Long message and explanation
UITC	UI TEMP CUTOFF User interface (LCD display and control panel) temperature cutoff activated.
ZSER	ZOOM SENSOR ERR Zoom position electrical indexing system timeout.

Table 6: Error messages

The fixture reports a calibration error if valid calibration data is not detected in EEPROM. The fixture may be unable to read/write calibration data to EEPROM.



www.martin.com