

HPX-MSP-7 HydraPort Touch 7" Connection Port

Overview

The HPX-MSP-7 is an 8 Module HydraPort Touch Connection Port with a 7" Modero S Series Touch Panel built into the cover. When closed, the unit sits nearly flush with the table top to keep the meeting space neat and clean. When open, the unit provides easy access to up to eight HydraPort Connectivity Modules and a full-featured Modero S Series Touch Panel.

Product Specifications

HPX-MSP-7 SPECIFICATIONS	
Models Available:	<ul style="list-style-type: none"> • HPX-MSP-7-SL, Silver; FG571-08 • HPX-MSP-7-BL, Black; FG571-07
Weight	3.58 lbs (1.62 Kg)
Dimensions (HWD):	4.567" (116mm) x 10.571" (268.51) x 6.526" (165.75mm) - see FIG 3
Cutout Dimensions:	Width: 8.358" (212.30mm), Length: 5.915" (150.25mm)
Power Consumption	Full-On: 11W, Typical: 7.5W, Standby: 4.5W, Shutdown: 0.7W
External Power Supply Required	Optimal performance requires use of one of the following AMX PoE power supplies (not included): <ul style="list-style-type: none"> • PS-POE-AF-TC, PoE Injector, 802.3AF Compliant (FG423-83) • NXA-ENET8-2POE, Gigabit PoE Ethernet Switch (FG2178-63) <i>Note: AMX does not support the use of non-AMX power supplies.</i>
Certifications	<ul style="list-style-type: none"> • FCC Part 15 Class B • AS/NZS CISPR 22 Class B • EN 55022 Class B and EN 55024 • IEC/EN-60950 • RoHS/WEEE compliant
Environmental	<ul style="list-style-type: none"> • Temperature (Operating): 32°F to 104°F (0°C to 40°C) • Temperature (Storage): 4°F to 140°F (-20°C to 60°C) • Humidity (Operating): 20% to 85% RH • Humidity (Storage): 5% to 85% RH • Heat Dissipation: On: 22.2 BTU/hr, Standby: 14.3 BTU/hr
Included Accessories	<ul style="list-style-type: none"> • Cardstock Installation Cutout Template, 7" HydraPort Touch (68-0571-01) • 4 Side Clamps (EMA5968-54) • 4 Tie-Wraps (45-0009A)
Optional Accessories	<ul style="list-style-type: none"> • HPX-AC-TMPLT-MSP7, Aluminum Installation Router Guide (FG559-95) • HydraPort Connectivity Modules - build your own custom configuration at www.amx.com/hydraportpreview

Note: For more detailed product specifications, refer to the HPX-MSP-7/10 Installation & Hardware Reference Manual.

Installing the HPX-MSP-7

Read these instructions in their entirety before beginning the installation.

CAUTION: This installation requires specific woodworking skills. This installation should be performed by an experienced person, comfortable with woodworking operations. Only a professional, AMX-qualified installer should perform this installation. Installation must conform to all local codes. This product may not be installed by the end-user.

1) Insert Additional HydraPort Connectivity Modules

Additional HydraPort Connectivity Modules are installed in the HPX-MSP-7 by sliding them on to the mounting rails (similar to other HPX Assemblies).

Note: A typical installation will include several additional HydraPort Connectivity Modules. HydraPort Connectivity Modules often require backside termination. Refer to the installation guide for each Module for details. The backside termination for each Module can and should be completed before the Module is installed into the HPX-MSP-7.

To access the mounting rails, remove either of the side covers from the HPX-MSP-7:

1. Remove the 6 Philips-head Mounting Screws that secure the Side Cover to the HPX base assembly (FIG. 1):

Note: Do not remove the two upper socket screws.

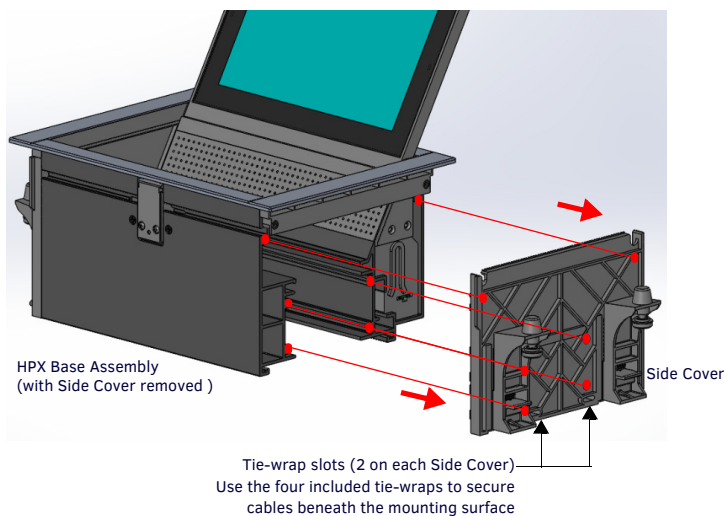

FIG. 1 REMOVING THE SIDE COVER

2. Gently lift one end of the Side Cover to free it from the enclosure, then carefully pull the opposite side to remove it. Note that with the Side Cover removed, the mounting rails (inside the enclosure) are accessible (see FIG. 1).
3. Slide the pre-terminated modules one at a time onto the mounting rails. Note the orientation of each module: the faceplate on each HPX module has a tab on one side and a matching notch on the other. These tabs and notches allow the modules to interlock when installed. Ensure that the modules are oriented consistently, so that the faceplates are stacked and interlocked when the modules are installed on the mounting rails (see FIG. 2).

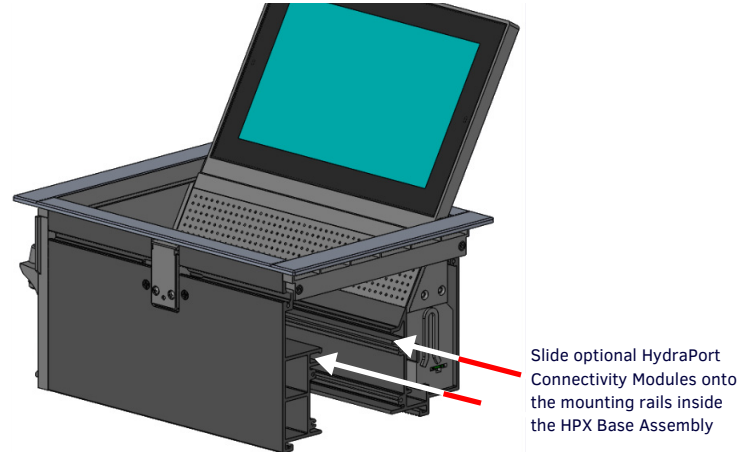

FIG. 2 INSERTING MODULES INTO THE HPX BASE ASSEMBLY

Route the cables from each module up through the bottom of the base assembly. Refer to each HPX module's Installation Guide for installation and termination details.

4. Replace the side cover on the HPX-MSP-7:
 - a. Insert the leading edge of the Slide Cover in to the HPX-MSP-7 Base Assembly enclosure.
 - b. Make sure that the Slide Cover is aligned with the tabs on the edge of the enclosure.
 - c. Gently press the other side of the Side Cover so that it snaps into place.
 - d. Replace all six Philips-head Mounting Screws.

2) Select a Suitable Location

Note the dimensions and space requirements for installing the HPX-MSP-7 (FIG. 3).

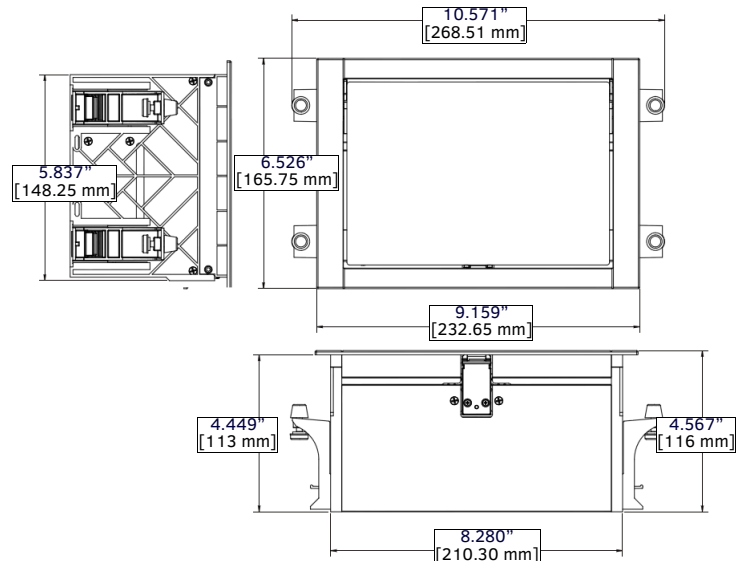

FIG. 3 HPX-MSP-7 DIMENSIONS

- Always use an appropriate template (either the included Cardstock Cutout Template, or the optional HPX-AC-TMPLT-MSP7 Aluminum Installation Router Guide) to establish the size of the hole needed to install the HPX-MSP-7. It is crucial to the installation that the cutout hole is located and sized properly.
- Take care to ensure that the system does not interfere with the normal use of the workspace. For example, on a table or work surface, ensure that the system does not interfere with the user's legs when they are seated at the table.
- If installing HydraPort Retractable Cable Modules, ensure that the pull-out length of the cable (1.5m) can reach all potential users, as excessively pulling on a fully extended cable can irreparably damage the retractor module.
- Refer to the *Mounting Surface Requirements* below:

Mounting Surface Requirements

Above Mounting Surface:	9.57" x 10.55" x 4.53" (243mm x 268mm x 115mm)
Below Mounting Surface:	15.08" x 11.54" x 6.26" (383mm x 293mm x 159mm)
Mounting Surface Thickness:	Min: 0.5" (12.7mm) / Max: 2.0" (50mm)

3) Cut the Hole In the Mounting Surface

The HydraPort Touch Base Assembly comes with a Cardstock Installation Template that can be used to locate the perfect spot and to mark the perimeter for cutting the table surface. The following cutout dimensions are required for the HPX-MSP-7 Base Assembly:

Width	Length
8.358" (212.30mm)	5.915" (150.25 mm)

Note: Very little clearance exists between the HydraPort Base Assembly and the hole cutout in the mounting surface.

CAUTION: Avoid creating a cutout that is smaller than the specified dimensions. If the cutout hole is cut too small, the HPX Base Assembly may be "squeezed" slightly when installed, which can adversely affect Flip-up motions due to friction.

- Use the included 7" Cardstock Installation Template to locate the desired position of the HydraPort Touch Base Assembly.
- Use the Cardstock Installation Template to mark the edges of the cutout.
 - Align the cutout carefully with the edges or other features of the mounting surface. If the cutout is misaligned, the installed unit will be misaligned.
 - Take care to ensure that the top surface of the mounting surface is not damaged beyond the width of the trim bezel as the cutout is made.
- Use an appropriate drill and drill bit to make a starting hole within the boundary of the cutout. Use an appropriate saw, such as a jigsaw to finish the cutout.
- Make sure cutting tool used is appropriate for the material to be cut and will not tear or chip the top surface.
- Ensure that the cutting tool maintains a straight vertical angle so that the interior cutout dimensions are accurate and consistent.
- Note that the process of making the cutout will create substantial dust and prepare the environment appropriately.

4) Install the HPX-MSP-7 Into the Mounting Surface

The HPX-MSP-7 uses four Side Clamps (included) to secure the unit to the mounting surface - no tools required:

- Run all cables that are connected to the installed HydraPort Connectivity Modules through the cutout in the mounting surface.
- Slide the HPX-MSP-7 into the cutout. Make sure that the top of the unit is level and nearly flush with the top of the mounting surface (FIG. 4):

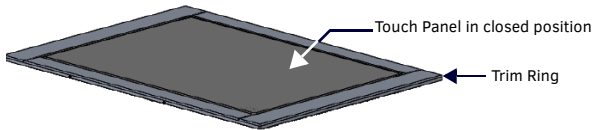

FIG. 4 HPX TOUCH INSTALLED IN THE MOUNTING SURFACE CUTOUT

Note that the trim around the top of the HPX covers the edges of the cutout hole.

- Use all four included Side Clamps to secure the HPX-MSP-7 to the mounting surface (FIG. 5):

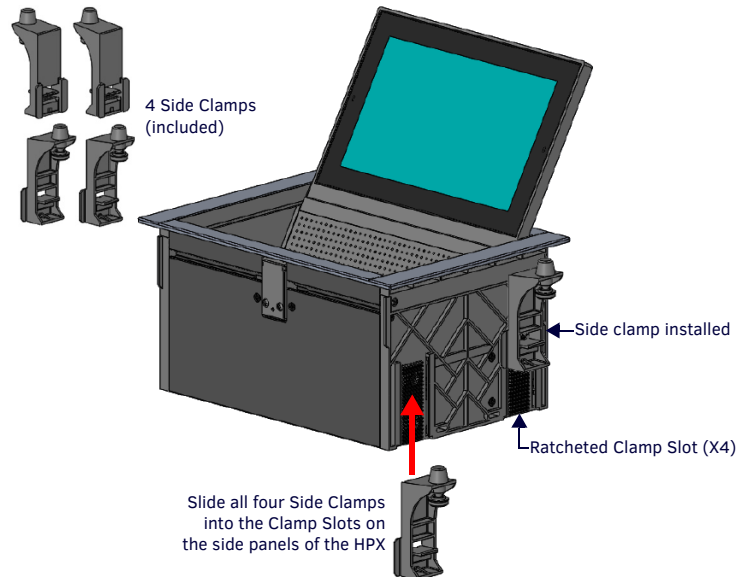

FIG. 5 HPX TOUCH ASSEMBLY AND SIDE CLAMPS

To slide a Side Clamp into one of the Clamp Slots on the side of the HPX base assembly:

Mounting Surface (bottom side)

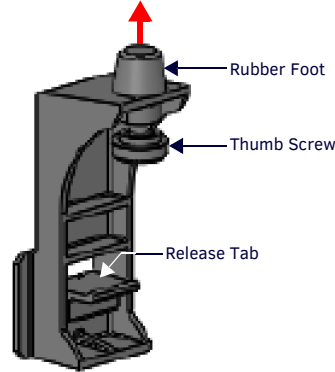

FIG. 6 SIDE CLAMP (X4)

Insert the four Side Clamps as far as they will go into the four Clamp Slots

Tighten the thumb screw to raise the rubber foot until it is pressed securely against the bottom side of the mounting surface

Press the Release Tab down to insert the Side Clamps in the ratcheted Clamp Slots on the HPX Side Panels

- Insert the Slide Clamp into a Clamp Slot on the HPX Base Assembly.
- Press down on the Release Tab on the Side Clamp (see FIG. 5), and slide the clamp into the ratcheted Clamp Slot until it contacts the underside of the mounting surface.
- Release the Release Tab to lock the Clamp into position. To adjust the Clamp position in the Clamp Slot (or to remove the Clamp), press the Release Tab and move the Clamp as necessary. Do this for all four Side Clamps. Ensure that all four clamps are fully inserted, and are all touching the underside of the mounting surface.
- Tighten the thumb screws on all four Clamps to secure the HPX assembly to the mounting surface (FIG. 7):

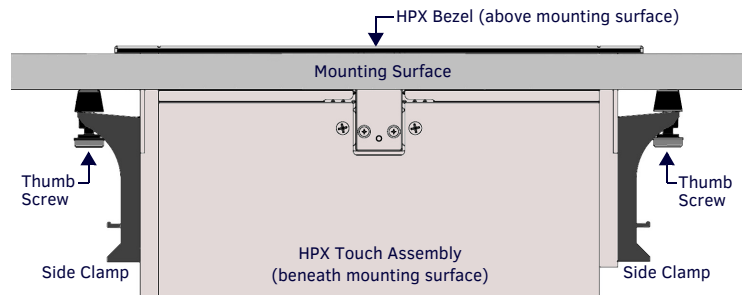

FIG. 7 TIGHTEN THE SIDE CLAMPS TO SECURE THE HPX TO THE MOUNTING SURFACE

- Repeat this process for the remaining three Side Clamps. All four clamps should be used.
- When all four Side Clamps are installed, re-check each of the thumb screws and make sure they are all tight.

5) Connect Ethernet and USB Cables

Once the HPX unit is installed in the mounting surface, plug in the Ethernet and (optionally) USB cable. The Ethernet and USB ports are located on the bottom of the HPX unit (FIG. 8):

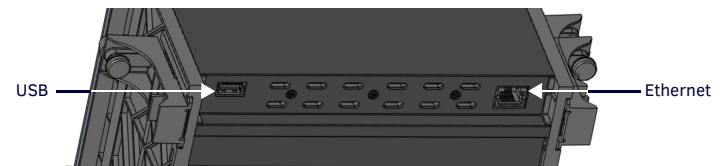

FIG. 8 HPX BOTTOM VIEW - ETHERNET AND USB PORTS

- Ethernet:** Connect to an 802.3AF compliant PoE power supply (PS-POE-AF-TC or NXA-ENET8-2POE, not included).
- USB:** Can be used for up to four actions (two commissioning, and two for end users): Firmware upgrade, touch panel file transfer, JPEG image viewer, and HID Peripherals.

Note: For end user access to USB drive, use a single or double USB HydraPort module such as HPX-N100-USB or HPX-N102-USB. For end user HID peripheral such as a mouse or keyboard, plug directly (or via a 3rd party USB hub) into the HPX Touch unit.

Note: Use the tie-wrap slots provided on the lower edge of each of the Side Covers (see FIG. 1) to secure cabling to the HPX and modules, via the four included tie-wraps.

Additional Information

- Detailed specification and installation drawings for the HPX-MSP-7 are available at www.amx.com.
- For instructions on removing the touch panel from the HPX-MSP-7 (for factory repair), refer to the *HydraPort Touch Connection Port Hardware Installation Guide*.
- For information on configuring the touch panel in the HPX-MSP-7, refer to the *Modero G4 Touch Panels Configuration and Programming Guide*.