

**Overview**

The MET-7 Metreau 7-Button Keypad (FG5794-03) offers 7 double-width buttons that can be used as individual keypad or in conjunction with the MET-6N and MET-13 Metreau keypads (FIG. 1).

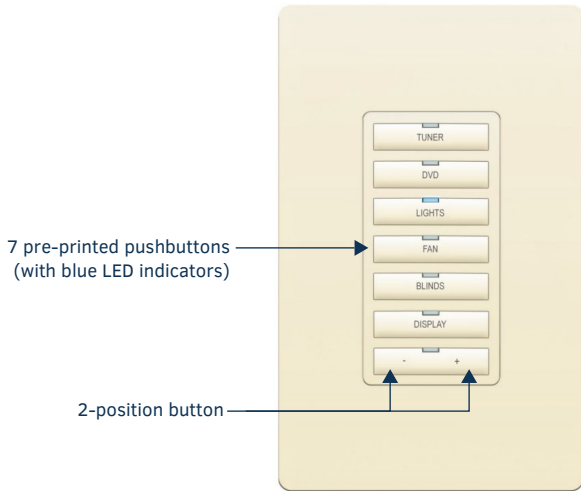

**FIG. 1** MET-7 METREAU 7-BUTTON KEYPAD

The MET-7 is an AxLink keypad, suitable for use in NetLinX Control Systems.

**Specifications**

MET-7 SPECIFICATIONS	
Power:	12 VDC, 30 mA
Front Panel Components:	Pushbuttons - 7 tactile pushbuttons with blue LED indicators that illuminate when pressed to confirm the source/function was selected and that it is currently being used. These pre-printed buttons are field-replaceable. The bottom button functions as 2 buttons - there are 2 positions (left and right) that allow the user to control channel/levels (up/down).
Rear Panel Components:	<ul style="list-style-type: none"> <li>DIP switch - 8-position mini DIP switch used to set the device address for the keypad on the AxLink Bus (1-255).</li> <li>AxLink connector - 4-pin 3.5mm Phoenix connector for AxLink connection to the NetLinX Master.</li> </ul>
Dimensions (HWD):	<ul style="list-style-type: none"> <li>Keypad and Mounting Plate: 4.055" x 1.772" x 0.818" (103mm x 45mm x 207mm)</li> <li>Mounts into standard decora-style wall plates.</li> </ul>
Weight:	2.4 oz. (68.04 g)
Operating Environment:	<ul style="list-style-type: none"> <li>Operating Temperature: 32° - 104° F (0° - 40° C).</li> <li>Relative Humidity: 5% - 85%, non-condensing.</li> <li>Intended for indoor use only.</li> </ul>
Certifications:	<ul style="list-style-type: none"> <li>FCC Class B</li> <li>CE</li> <li>IEC60950</li> <li>RoHS</li> </ul>
Colors:	<ul style="list-style-type: none"> <li>White (FG5794-03-WH)</li> <li>Black (FG5794-03-BL)</li> <li>Light Almond (FG5794-03-LA)</li> </ul>
Optional Accessories:	<ul style="list-style-type: none"> <li>Single Button Kit (FG5794-10)</li> <li>Double Button Kit (FG5794-11)</li> <li>Lutron Cairo Wallplates (available in a variety of sizes and colors)</li> </ul>

**Installation**

to uching argidient lj .i d giNgCngTNEri : r. gid giEd dmigBndrbidfi ravi faeri, aNfi , fi touching a grounded metal object.

FIG. 2 shows the basic rear components of the MET-7 keypads:

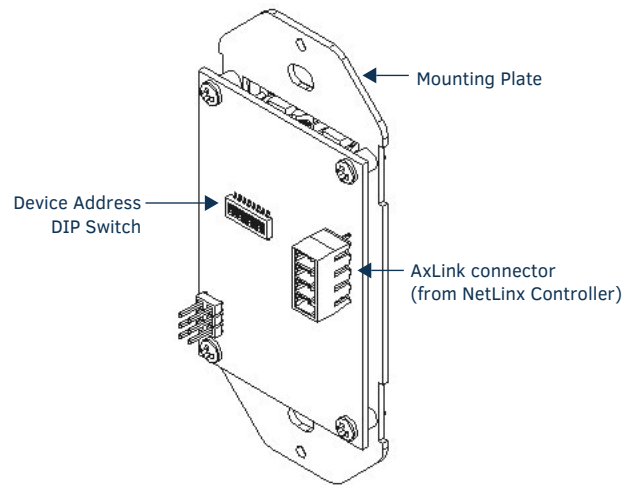

**FIG. 2** MET-7 - REAR COMPONENTS

**AxLink Device Addressing**

AxLink-enabled Metreau keypads use an 8-position mini-DIP switch to specify a unique device address for each keypad in a NetLinX Control System.

*NOTE: Before touching the device, discharge the static electricity from your body by touching a grounded metal object.*

1. If connected, disconnect the power supply.
2. Locate the 8-position mini-DIP switch on the rear panel.
3. Set the DIP switch according to the values shown in FIG. 3.

Switch	1	2	3	4	5	6	7	8
Value	1	2	4	8	16	32	64	128

**FIG. 3** 8-POSITION MINI-DIP SWITCH

The device number is set by the total value of DIP switch positions that are in the ON position. Note that the ON position is indicated on the DIP Switch.

As an example, the DIP switch in FIG. 3 defines AxLink device number 129 (1+128=129).

If you later change the device number, remove and reconnect the power connector to enter the new device number into memory.

**Wiring**

**Preparing captive wires**

sy wuMothikajj adnøj j gnōpaDgriidid gi- gdq: eiagfp: Niej dBil giDbrlj .i lEinov pBdq; sy wuMothiMieEļj .i paDgri ravi yK/lj qTNLEnøj j gndid giDbrlj .i ravi d ginaj draBEfEdyvi before wiring the Metreau keypads.

You will need a wire stripper, and flat-blade screwdriver to prepare and connect the captive wires.

1. Strip 0.25 inch (6.35 mm) of wire insulation off all wires.
2. Insert each wire into the appropriate opening on the connector according to the wiring diagrams and connector types described in this section.
3. Turn the flat-head screws clockwise to secure the wires in the connector.

*NOTE: Do not over-torque the screws; doing so can bend the seating pins and damage the connector.*

## Wiring guidelines

Metreau keypads require 12 VDC power to operate properly. The necessary power is supplied via the AxLink or SWT cable. The maximum wiring distance is determined by power consumption, supplied voltage, and the wire gauge used for the cable. The following table lists wire sizes and the maximum lengths allowable based on the maximum power consumption rating of 170 mA.

AXLINK WIRING GUIDELINES AT 170 MA	
Wire Size	Maximum Wiring Length
18 AWG	690.42 feet (210.43 m)
20 AWG	436.80 feet (133.13 m)
22 AWG	272.33 feet (83.00 m)
24 AWG	171.66 feet (52.32 m)

The maximum wiring lengths for using AxLink power are based on a minimum of 13.5 volts available. If the distance is greater than what is listed in the table, consult the *Metreau Keypads Operation/Reference Guide* for wiring with external power sources.

### AxLink Data and Power Connections

Connect the control system's AxLink connector to the AxLink connector on the rear panel of the Metreau Keypad for data and 12 VDC power as shown in FIG. 4.

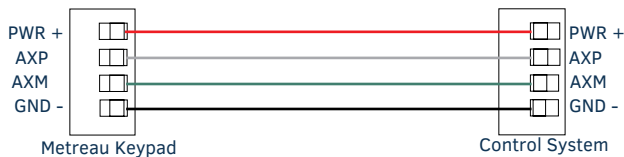

FIG. 4 AXLINK STRAIGHT-THRU WIRING

### Using AxLink for Data with an Auxiliary Power Supply

Use an auxiliary 12 VDC power supply when the distance between the controller and server exceeds the limits described in the *Wiring Guidelines* section. Connect only the GND (-) wire on the AxLink connector when using an auxiliary 12 VDC power supply. Connect the NetLinx Controller's AxLink connector to the AxLink connector on the rear panel of the Metreau keypad, as shown in FIG. 5.

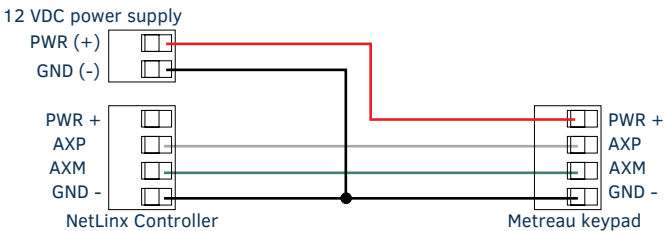

FIG. 5 AXLINK AND 12 VDC POWER SUPPLY WIRING DIAGRAM

**NOTE:** If you are not using power from AxLink, disconnect the wiring from the controller before wiring the Metreau keypad. Make sure the auxiliary power supply's PWR (+) is not connected to the controller's AxLink connector.

### AxLink Status LED

The AxLink Status LED (located next to the AxLink connector), lights to indicate AxLink power/data status (see Operation / Reference Guide for details).

If the LED is on and not flashing, disconnect the AxLink connector and recheck all AxLink connections. Then, reconnect the AxLink connector to the panel and verify the LED is flashing once per second.

### Mounting Procedures

AMX recommends mounting Metreau keypads in standard U.S.-style decora wallboxes:

- Conduit box should meet NEC specs (section 370)
- Minimum internal clearance of (HWD) 2-5/8" x 1-3/4" x 1-5/8".

**NOTE:** Before touching the device, discharge the static electricity from your body by touching a grounded metal object.

### Wallbox Mounting

1. Use the cutout dimension for the wallbox to cutout the install surface.
2. Connect the AxLink connector (or SWT cable connectors) to the rear of the keypad.
3. Place the Mounting Plate on the wallbox; align the screw holes with the mounting holes and fasten the Mounting Plate to the wallbox using the screws supplied.

**NOTE:** Do not overtighten the screws when mounting the Mounting Frame. The device should be flush with mounting surface.

## Mounting Dimensions

FIG. 6 provides detailed dimensions for the 7-button Metreau keypads.

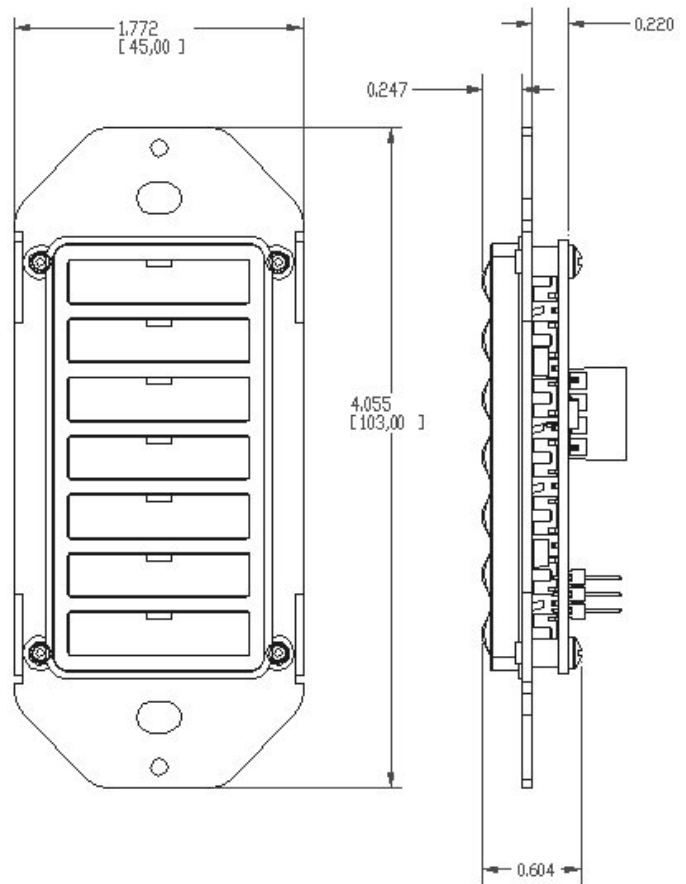

FIG. 6 MOUNTING DIMENSIONS - MET-7

## Programming

There are a select number of SEND\_COMMANDs the Metreau keypad recognizes. For a full list and descriptions, consult the *Metreau Keypads Operation/Reference Guide*.

### Sending Firmware to Metreau Keypads (AxLink)

The Firmware on the AxLink-enabled Metreau keypads (MET-6N, MET-7 and MET-13) can be updated via the NetLinx Studio2 application:

**NOTE:** Refer to the NetLinx Studio 2 online help for additional details on firmware transfers. NetLinx Studio 2 is available for free download from [www.amx.com](http://www.amx.com).

1. Open NetLinx Studio2.
2. Go to **Tools > Firmware Transfers > Send to Access Device...** This opens the *Send to Access Dialog Window*.
3. Browse to the location of the firmware file.
4. Select the file within the *Files* frame.
5. Click **Query for Devices**.
6. Select the Metreau keypad within the *Devices* frame.
7. Click **Send** and then **Close**.
8. Upon confirmation of a successful send, you can exit NetLinx Studio2.

### Additional Documentation

Refer to the *Metreau Keypads Operation/Reference Guide* (available online [www.amx.com](http://www.amx.com)) for additional information on configuration, programming and using the Metreau keypads.

