

NOTES: UNLESS OTHERWISE SPECIFIED

1. DIMENSIONS IN [] ARE MILLIMETERS

| REVISION HISTORY | | | | | |
|------------------|------|-------------------|-----------------|------|-----|
| DATE | REV. | PREVIOUS PART NO. | DESCRIPTION | ZONE | BY |
| 6/23/2017 | A | 95-0571-09 | INITIAL RELEASE | | CAI |

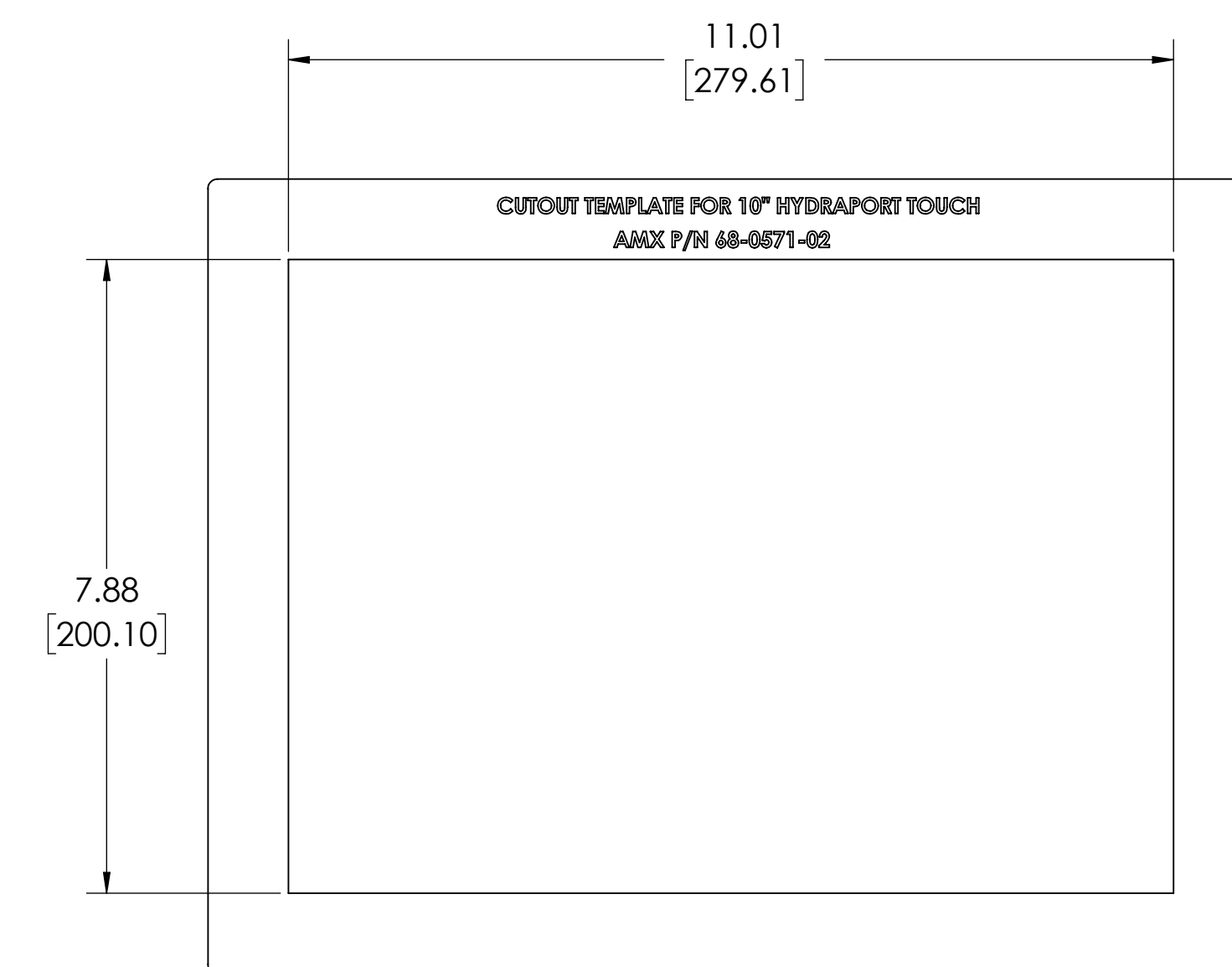
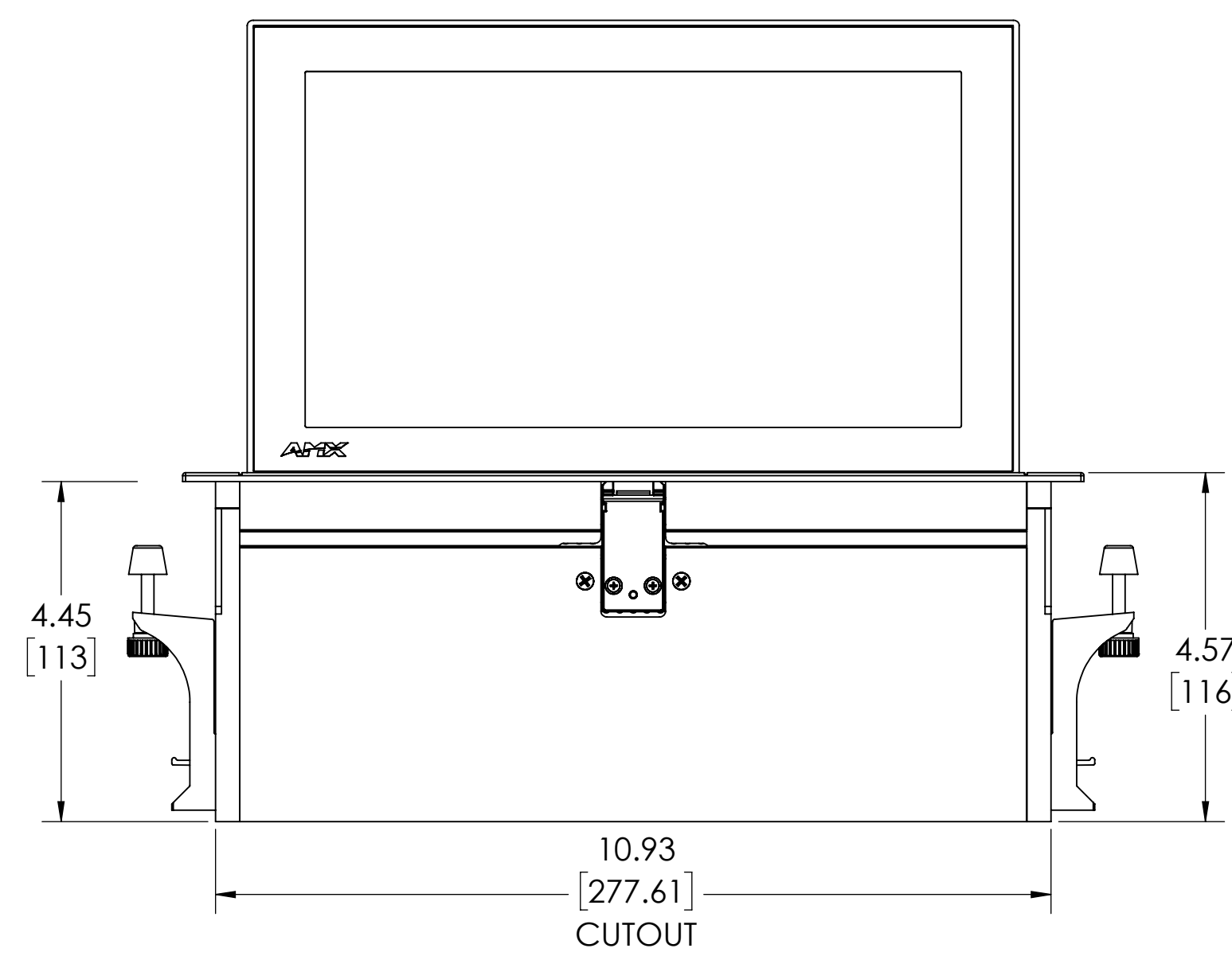
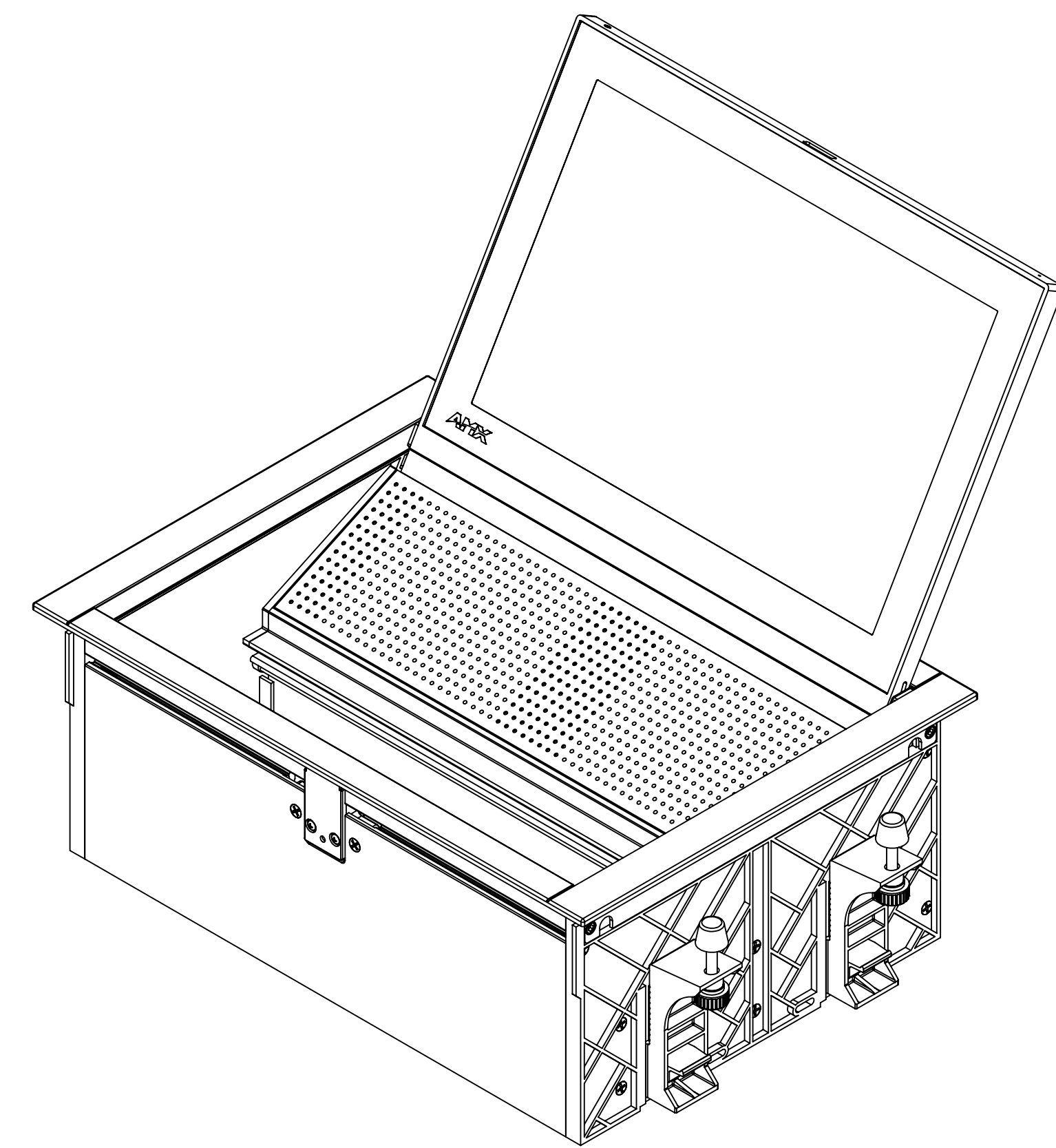
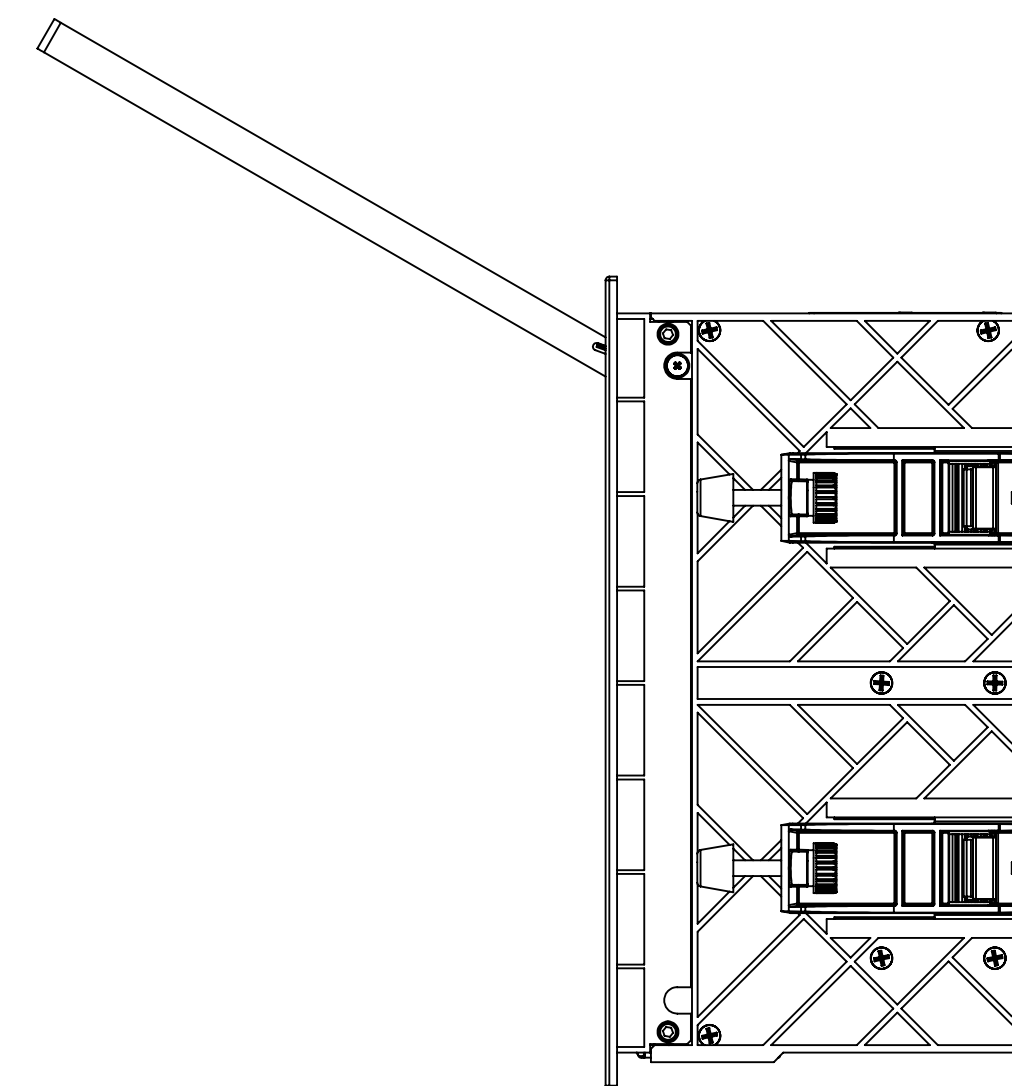
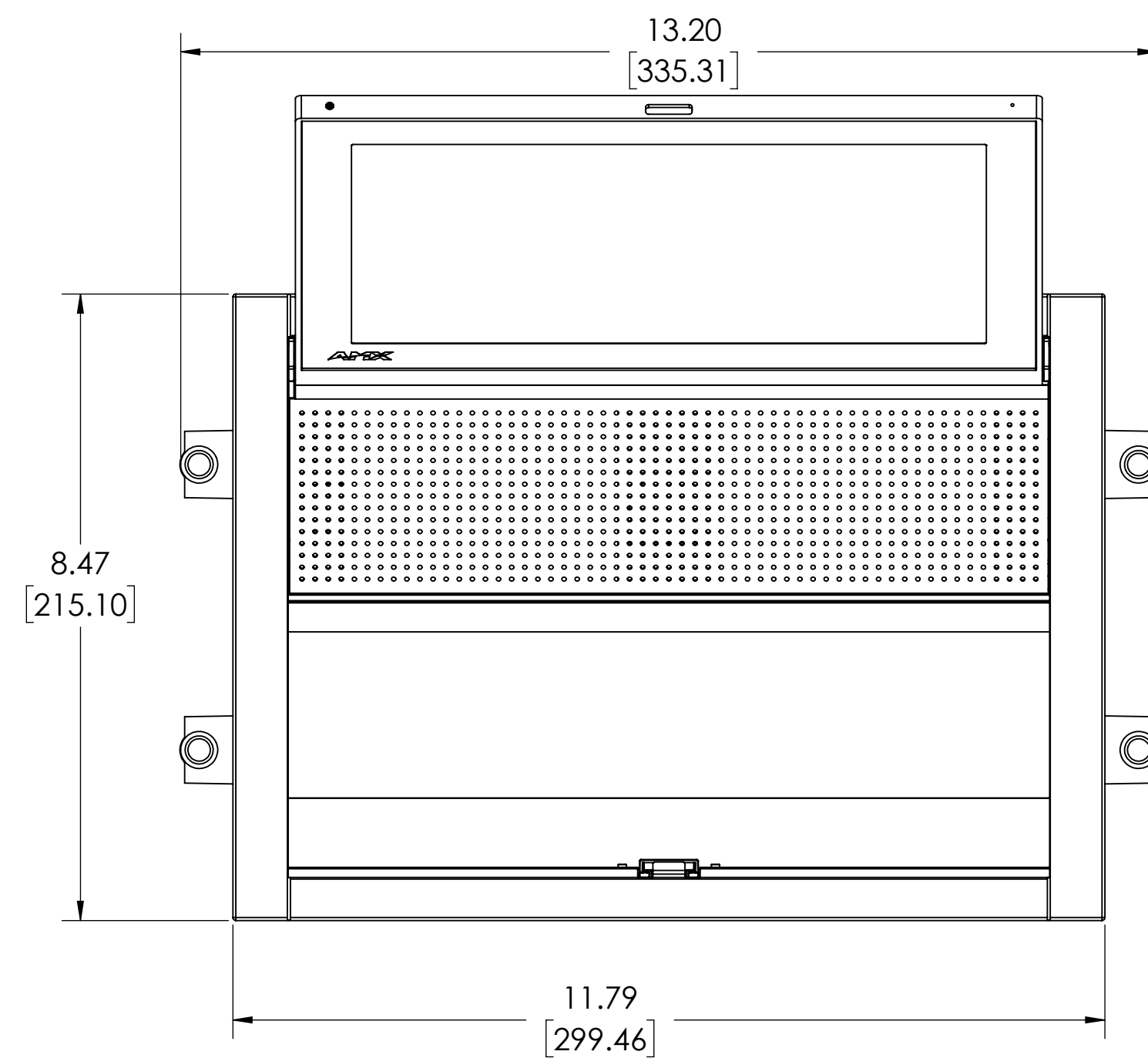
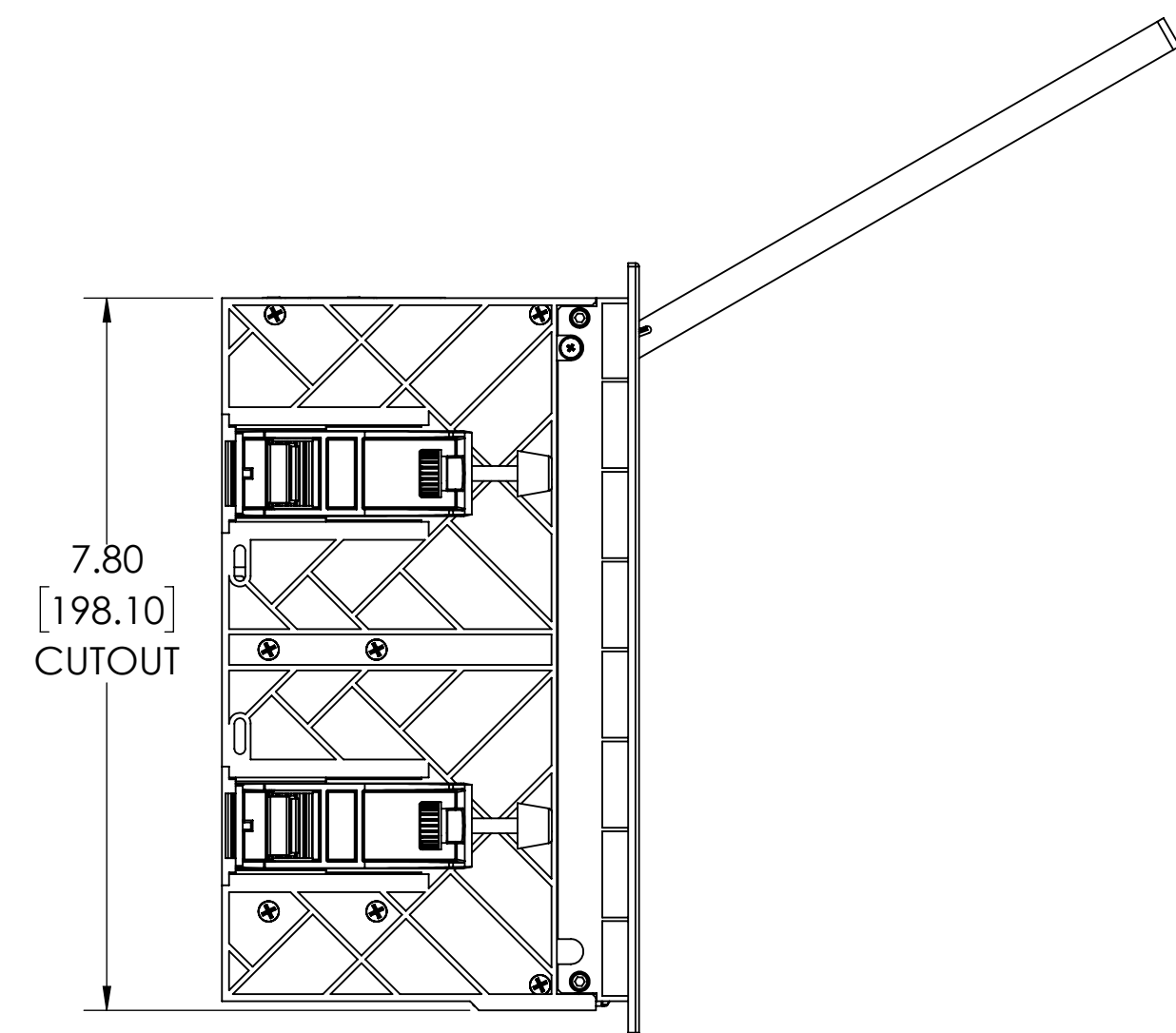

| | | | | |
|----------------------------------------------------------------------------------------------------------------------------------------------------------------------------------------------------------------------------------------------------------------------------------------------------------------------------------------------------|------------------------------------------------------------------------------------------------------------------------------------------------------------|------------------------------------|--------------------------------------------------------------------------------------------------------|-------------------------------------|
| PROPRIETARY AND CONFIDENTIAL PROPERTY OF HARMAN. DO NOT DISCLOSE, REPRODUCE, OR FURNISH WITHOUT WRITTEN HARMAN APPROVAL. ROHS RESTRICTION OF HAZARDOUS SUBSTANCES ALL MATERIALS USED IN THIS PART MUST BE ROHS COMPLIANT. SUPPLIER SHALL PROVIDE A CERTIFICATE OF ROHS COMPLIANCE WITH THE FIRST ARTICLE. | TOLERANCES UNLESS OTHERWISE SPECIFIED: All Dimensions: ±.005 Angular: ±.5° ALL DIMENSIONS ARE IN INCHES ALL DIMENSIONS APPLY AFTER FINISH. | THIRD ANGLE PROJECTION | HARMAN <small>1718 W. Mistrzewska Rd Elkhart, IN 46517 USA</small> | |
| | | | DRAWN BY: P. LE DESIGNED BY: P. LE ENGINEER: P. LE | DATE: 12/8/2015 DATE: 11/10/2015 |
| DIMENSIONS SHOWN ARE FOR REFERENCE AND INSPECTION ONLY. REFER TO DIMENSION LINES WITH THIS DRAWING FOR ORIGINAL DEFINITION OF PART GEOMETRY. | | SCALE: 1:2 DO NOT SCALE DRAWING | SHEET 1 OF 1 | |